

OLRB File No.: 1228-20-HS, 1236-20-HS 1239-20-HS, 1240-20-HS

**ONTARIO LABOUR RELATIONS BOARD**

**ONTARIO SECONDARY SCHOOL TEACHERS' FEDERATION, ONTARIO ENGLISH  
CATHOLIC TEACHER'S ASSOCIATION, ELEMENTARY TEACHERS' FEDERATION OF  
ONTARIO and L'ASSOCIATION DES ENSEIGNANTES ET DES ENSEIGNANTS  
FRANCO-ONTARIENS**

The Applicants

-and-

**A DIRECTOR UNDER THE OCCUPATIONAL HEALTH AND SAFETY ACT, HER  
MAJESTY THE QUEEN IN RIGHT OF ONTARIO (MINISTRY OF LABOUR, TRAINING  
AND SKILLS DEVELOPMENT) and HER MAJESTY THE QUEEN IN RIGHT OF  
ONTARIO (MINISTRY OF EDUCATION)**

The Responding Parties

-and-

**CANADIAN UNION OF PUBLIC EMPLOYEES,  
and COUNCIL OF TRUSTEES' ASSOCIATION**

The Intervenors

---

**EXPERT REPORT OF DR. JEFFREY SIEGEL**

---

**Ursel Phillips Fellows Hopkinson LLP**  
555 Richmond Street West  
Suite 1200  
Toronto, Ontario  
M5V 3B1

**Susan Ursel**  
Tel: (416) 969-3515  
Email: sursel@upfhlaw.ca

**Kristen Allen**  
Tel: (416) 969-3502  
Email: kallen@upfhlaw.ca

**Emily Elder**  
Tel: (416) 969-3523  
Email: eelder@upfhlaw.ca

Lawyers for the **OSSTF**

## INDEX

<u>TAB</u>	<u>DESCRIPTION</u>
1.	Dr. Jeffrey Siegel Report
A.	Appendix A – Curriculum Vitae of Dr. Jeffrey Siegel
1.	Tab 1 - ASHRAE Standard 62.1 “Ventilation for Acceptable Indoor Air Quality”
2.	Tab 2 – Transmission of SARS-CoV-2: implications for infections prevention precautions, Scientific Brief, World Health Organization dated July 9, 2020
3.	Tab 3 – Updated Sick Kids Report, COVID-19: Guidance for School Reopening, July 29, 2020
4.	Tab 4 – Review Article, Role of Ventilation in airborne transmission of infectious agents in the built environment – a multidisciplinary systematic review
5.	Tab 5A – ASHRAE Epidemic Task Force, Schools and Universities, updated July 17, 2020
	Tab 5B – ASHRAE Epidemic Task Force, Building Readiness, updated August 19, 2020

**TAB 1**

## SUMMARY OF QUALIFICATIONS

1. I received my Ph.D. in Mechanical Engineering from the University of California at Berkeley in 2002. Prior to that, I received my M.S. in 1999 from the same department and my B.S. in Engineering in 1995 from Swarthmore College. I am currently a professor in the Department of Civil & Mineral Engineering at the University of Toronto (UofT) and I have adjunct appointments in the Dalla Lana School of Public Health and Department of Physical & Environmental Sciences. I started at UofT in 2013 as an associate professor (with tenure) and was promoted to full professor in 2015. Prior to 2013, I was first an assistant professor and later a tenured associate professor at the University of Texas at Austin. Almost all of my research focuses on indoor air quality, ventilation, heating, ventilation, and air conditioning (HVAC) systems, indoor aerosol transport, and filtration. I am an active member of the American Society for Heating, Refrigeration, and Air-Conditioning (ASHRAE), The International Society of Indoor Air and Climate (ISIAQ), and the American Association of Aerosol Research (AAAR) and am a fellow of ASHRAE and member of the Academy of Fellows of ISIAQ.
2. A detailed description of my qualifications is set forth in my curriculum vitae (CV), which is attached hereto as Appendix A. A list of my journal publications and other scientific and academic contributions is also set forth in my CV.

## RESPONSE TO QUESTIONS

- i. **Please describe the basic elements and functions of an HVAC (heating, ventilation, air conditioning) system, including the role played by air movement, air exchange, air pressure, filtration, outdoor weather and temperature, humidity, and how ventilation interacts with heating and cooling. Please define key terms, including indoor environment quality (IEQ) and indoor air quality (IAQ).**

*All quoted definitions in this section are based on the American Society of Heating, Refrigerating and Air-Conditioning Engineers (ASHRAE) terminology (<https://www.ashrae.org/technical-resources/free-resources/ashrae-terminology>). ASHRAE is the dominant professional society globally for HVAC issues.*

3. An **HVAC (heating, ventilation, air conditioning) system** is “the equipment, distribution systems, and terminals that provide, either collectively or individually, the processes of heating, ventilating, or air conditioning to a building or portion of a building.” Of particular importance is the term **air conditioning**, which colloquially means cooling but technically (and in this report) refers to “the process of treating air to meet the requirements of a conditioned space by controlling its temperature, humidity, cleanliness, and distribution.”
4. The ultimate functions of HVAC systems can include adding heat and/or humidity to the air (i.e., heating, humidification), removing heat and/or humidity (i.e., cooling, dehumidification) to the air, providing fresh air to dilute indoor contaminants including those generated by occupants (i.e., ventilation), filtration and air cleaning, and distribution of conditioned air to spaces in the building (i.e., air movement). Any given building may have HVAC systems that do some or all of the above functions, multiple HVAC systems that work independently or in concert, control systems (e.g., thermostats, timeclocks) that change the output of one or more parts of HVAC system, subsystems that involve intermediate steps (e.g., a chiller that makes chilled water that is then used to cool and dehumidify the air in the building), and may include supplementary systems that are moveable and intended to provide air conditioning to specific spaces in the building.

5. The basic function of all HVAC systems is that they respond to input from a control system and/or manual switches and provide conditioning to the air. This basic function can be range from being very simple, for example a manual switch that turns on an exhaust fan in a bathroom, to very complex, for example a control system that integrates a variety of indoor and outdoor measurement points in a building as well as parameters reported by HVAC components and provides different levels and types of conditioning and ventilation to different spaces. In general, HVAC systems are operated to provide comfort and acceptable indoor air quality to the building occupants and also may provide more specific air conditioning (e.g., enhanced air cleaning)
  
6. Of particular importance to this report is the concept of **ventilation** defined as the “(1) the process of supplying air to or removing air from a space for the purpose of controlling air contaminant levels, humidity, or temperature within the space. (2) the process of supplying or removing air by natural or mechanical means to or from any space. Such air may or may not have been conditioned.” Embodied in the definition above is the distinction between **mechanical ventilation** “(1) the active process of supplying or removing air to or from an indoor space by powered equipment such as motor-driven fans and blowers but not by devices such as wind-driven turbine ventilators and mechanically operated windows. (2) ventilation provided by mechanically powered equipment, such as motor-driven fans and blowers, but not by devices such as wind-driven turbine ventilators and mechanically operated windows.” and **natural ventilation** “movement of air into and out of a space primarily through intentionally provided openings (such as windows and doors), through nonpowered ventilators, or by infiltration.” In general, the purpose of ventilation is to provide **ventilation air** “the minimum amount of outdoor air required for the purpose of controlling air contaminant levels in buildings,” but it can also be used to offset cooling, conduct building flush outs to deal with periods of high indoor emissions, and/or to maintain pressurization or depressurization of particular spaces to manage local emissions, protect specific indoor spaces, or minimize the likelihood of building enclosure moisture problems.

7. Another ventilation concept that is important to the discussion of HVAC systems in schools is that many systems are designed to recirculate some (or even most) of their air, usually because of energy or comfort concerns. **Recirculation air** is defined as “air taken from a space and returned to that space, usually after being passed through a conditioning system. The part of the return air that is reused. Air removed from a space and reused as supply air.” In the context of infectious disease transmission, recirculation air can contain particles and/or droplets that contain the infectious agent and unless the air is filtered to remove the infectious agent, recirculation air can lead to the spread of infectious disease within a building.
  
8. Ventilation has a strong influence on the cleanliness and quality of indoor air. The **indoor environment quality (IEQ)** is defined as “a perceived indoor experience of the building indoor environment that includes aspects of design, analysis, and operation of energy efficient, healthy, and comfortable buildings. Fields of specialization include architecture, HVAC design, thermal comfort, indoor air quality (IAQ), lighting, acoustics, and control systems.” Within this definition, ventilation most strongly influences **indoor air quality (IAQ)** is defined as “attributes of the respirable air inside a building (indoor climate), including gaseous composition, humidity, temperature, and contaminants.” Note that these definitions do not directly address infectious disease, although most would consider an infectious disease agent as a contaminant.
  
9. The most common standard for ventilation comes from ASHRAE Standard 62.1 “Ventilation for Acceptable Indoor Air Quality”, attached at Tab 1 in Appendix A, most recently adopted in 2019. Most jurisdictions in Canada adopt ASHRAE Standard 62.1 as part of non-residential building codes. One purpose of the standard “is to specify minimum ventilation rates and other measures intended to provide indoor air quality (IAQ) that is acceptable to human occupants and that minimizes adverse health effects” and where acceptable IAQ is defined in the standard as “air in which there are no known contaminants at harmful concentrations, as determined by cognizant authorities, and with which a substantial majority (80% or more) of the people exposed do not express

dissatisfaction.” ASHRAE standard 62.1 is intended for application as a standard for new buildings and also to guide ventilation practices in existing buildings.

10. A key element of ASHRAE Standard 62.1 is Table 6.1, a portion of which is excerpted below in Figure 1. The minimum ventilation rate is determined from the people outdoor air rate (L/s/person) to address emissions from occupants and their activities and an area outdoor rate (L/s/m<sup>2</sup>) to address emissions from building materials and space contents for all spaces in the table. Functionally, many users of ASHRAE Standard 62.1 use default values that are the sum of the two rates based on an assumed maximum occupancy. There is one extremely important point about ASHRAE Standard 62.1 that is in footnote b to the table; “The requirements of this table provide for acceptable IAQ. The requirements of this table do not address the airborne transmission of airborne viruses, bacteria, and other infectious contagions.” This is why meeting ASHRAE Standard 62.1 minimums are only a baseline and ventilation should be larger than this value. It is also critical to point out that the minimum ventilation rates in Table 6.1 are for individual spaces within building and a given building might have very different minimum ventilation rates for different rooms/spaces.

**Table 6-1 Minimum Ventilation Rates in Breathing Zone**

Occupancy Category	People Outdoor Air Rate $R_p$		Area Outdoor Air Rate $R_a$		Default Values
	cfm/person	L/s-person	cfm/ft <sup>2</sup>	L/s-m <sup>2</sup>	Occupant Density
					#/1000 ft <sup>2</sup> or #/100 m <sup>2</sup>
<b>Educational Facilities</b>					
Art classroom	10	5	0.18	0.9	20
Classrooms (ages 5 to 8)	10	5	0.12	0.6	25
Classrooms (age 9 plus)	10	5	0.12	0.6	35
Computer lab	10	5	0.12	0.6	25

Figure 1: Excerpt from ASHRAE Standard 62.1-2019.



4. Some of the challenges with ventilation include the fact that outdoor air may not be clean of contaminants depending on the location of the building, and in addition to the broader issue of ambient air quality, proximity to major roadways, industrial sites, and other sources of air pollution may require filtration and/or other cleaning of the air in order for it to satisfy the need for ventilation. In most climates there are periods of the year where ventilation air may also need hygrothermal conditioning such that it satisfies comfort conditions in the building. Such conditioning may represent a substantial portion of building energy needs and will impact the required conditioning capacity of HVAC equipment. In particular, humidity (both an excess of and the absence of humidity) often limits the amount of ventilation that can be provided without sacrificing other HVAC goals.

ii. **In your opinion, can heating, ventilation, and air conditioning impact upon the transmission of COVID-19 in public schools in Ontario? If yes, please describe how, and outline the measures relating to heating, ventilation, and air conditioning that could be used to reduce the risk of transmitting COVID-19 in a public school setting in Ontario? What modifications, if any, would have to be made in respect of these measures, throughout the school year with the change in seasons?**

11. We know that COVID-19 can be transmitted through a variety of routes and the importance of these routes are environment dependent. Close contact is widely believed to be an important exposure route and this is the basis for guidance around physical distancing. The World Health Organization has also provided guidance about other transmission routes that can be important, including fomite and airborne routes (attached at Tab 2 in Appendix A). There is a lot of nuance in the airborne route of disease transmission in particular: the first is that there is often a distinction made between droplets ( $>5 \mu\text{m}$ ) and aerosols ( $<5 \mu\text{m}$ , also called droplet nuclei). Droplets are assumed to settle rapidly (e.g., within 2 m): this is a poor assumption in indoor environments as we have overwhelming evidence that a) droplets can be emitted and rapidly ( $< 1$  second) shrink to smaller sizes as water evaporates from the droplet (particularly at lower relative humidity) and b) local air currents can carry droplets outside of this 2 m range. Thus,

there is a longer-range exposure route to droplets that would not technically be considered airborne. Another issue is whether aerosols can cause infection. There is certainly evidence of longer-range (far beyond 2 m) in indoor environments transmission of COVID-19, but it is less clear if this was caused by particles that were originally emitted as droplets or as aerosols. The evidence against aerosol transmission is usually based around the fact that that COVID-19 is less likely to be transmitted by the airborne route than other infectious diseases such as measles and that we would expect to see more transmission in healthcare facilities if the airborne route was important. The first set of evidence (less likely to be airborne than measles) is very likely valid and that the airborne route may not *always* be important for COVID-19 transmission, but given what we know about the circumstances in Ontario schools (described below), we should certainly be protecting against the airborne route of transmission. The second set of evidence (healthcare facilities) is not a valid comparison to schools because we know that that health care facilities are much more likely than schools to have well-maintained HVAC systems with excellent filtration and ventilation (and often supplementary air cleaning such as ultraviolet irradiation), robust cleaning and infection control approaches, and much lower occupant densities. In many ways, low rates of airborne transmission in healthcare facilities make a strong argument for the important of ventilation and HVAC measures in other environments, such as schools.

12. We know that the biggest risk for COVID-19 airborne transmission comes from three factors: crowded, poorly ventilated, and time in environment. When all three factors are present, the risk is very high and it diminishes as we address these factors. Many schools are, by definition, crowded and thus physical distancing/reduced class sizes are the best way of addressing this factor. Physical distancing is a much more complicated concept indoors than it is outdoors. Factors like humidity, air currents and velocities, as well as smaller dilution rates by ventilation can combine to make infective particles and droplets travel far beyond the two meter distancing rule generally employed in outdoor air. In person learning means that students spend several hours in their classrooms making this factor hard to address. Thus, HVAC solutions are an important part of COVID-19 risk

reduction strategies because the one risk factor (poorly ventilated) of the three that can be mitigated with in person learning is with HVAC controls.

13. It is important to recognize that HVAC solutions are an important component of a larger strategy and engineering controls are part of a hierarchy of controls (as described below in response to Question 3). An example of this multifaceted approach is outlined in the Sick Kids COVID-19: Guidance for School Reopening dated July 29, 2020. This document outlines several measures, including addressing ventilation (Item 7), for reopening schools. The advice in this Sick Kids document is very consistent with the information in the previous paragraph: “Addressing structural deficiencies, such as large class sizes, small classrooms and poor ventilation, must be part of any plan to reopen schools.” There are additional measures in the Sick Kids document that also address ventilation in a different way. An example is potential infectious disease transmission on school buses (Item 16). Increased ventilation in transportation microenvironments has been shown to reduce disease transmission. School bus ventilation is complicated because it depends on many factors including the bus design and maintenance, the speed of travel, and the outdoor conditions (temperature, wind speed and direction). Having said that, there is evidence of airborne infectious disease transmission in school buses including Riley et al. (attached at Tab 3 in Appendix A) who investigate a measles outbreak in a school in New York State; “Home room exposures and bus exposures were much more important, after the first generation, in spreading infection among children in the new wing.” And further, the school buses in this investigation had a very high ventilation rate, much higher than that of more modern buses. The differences in the disease (measles vs. COVID-19) and unknown ventilation rates in Ontario school buses make it hard to draw firm conclusions, but there is clear possibility for poorly-ventilated school buses to lead to increased airborne infectious disease transmission.

14. Within this context of broader engineering controls, the primary HVAC solution strategy is ventilation. We are especially concerned about poorly ventilated spaces, defined here and by most as spaces that do not meet the minimum ventilation guidelines of the current version of ASHRAE Standard 62.1 (described above in response to Question 1). These

minimum guidelines are not intended to offer protection from infectious disease, but we do know that poor ventilation is a risk factor for many infectious diseases that spread similarly to COVID-19. As a starting point, every occupied space in every school in Ontario should be made to meet these minimum ventilation rates in ASHRAE Standard 62.1. This may require minimal modifications to existing HVAC systems, significant modifications, or the addition of new HVAC components, depending on the school. Some schools may have some occupied spaces that cannot meet this standard, and the use of such spaces should change.

15. There is overwhelming evidence of the benefit of ventilation for reducing infectious disease transmission. A key sentence from a 2007 article that reviewed 40 investigations on ventilation and the connection to infectious disease transmission and that was authored by some of the most prominent names in ventilation and infectious disease transmission (attached at Tab 4 in Appendix A), found the following. "There is strong and sufficient evidence to demonstrate the association between ventilation, air movements in buildings and the transmission/spread of infectious diseases such as measles, tuberculosis, chickenpox, influenza, smallpox and SARS." All guidance from ASHRAE and other cognizant authorities on ventilation is consistent with this fact.
16. However, minimum ventilation guidelines like those in ASHRAE 62.1 are written around the concept of acceptable air quality and not about reducing infectious disease transmission. The same article cited above found that "there is insufficient data to specify and quantify the minimum ventilation requirements in hospitals, schools, offices, homes and isolation rooms in relation to spread of infectious diseases via the airborne route." Another way of stating this quote is that we do not yet know of minimum ventilation rates to limit the spread of infectious diseases, let alone for a novel disease such as COVID-19. Thus, the appropriate recommendation is to increase ventilation as much as possible. There are practical constraints on ventilation in most buildings: fan capacities (can enough air flow be provided?), conditioning equipment capacities (can enough heating/cooling/humidification/dehumidification be provided), distribution limits (can the ventilation air be delivered to all spaces in the building?), poor outdoor air

quality (can the pollutants in outdoor be removed through filtration and air cleaning of the ventilation supply air?) and given that current knowledge does not provide a minimum ventilation rate that will limit the spread of disease, the best advice is to meet minimum ventilation guidelines for acceptable indoor air quality (i.e., ASHRAE Standard 62.1) and increase as much as possible and use supplementary measures such as filtration when ventilation cannot be raised above these standards. This approach reflected in the ASHRAE standards, checklists, and recommendations discussed in the response to Questions 4 and 5.

17. One of the most important challenges with increasing ventilation in Ontario schools is humidity. Schools in Ontario likely very rarely have effective humidification and dehumidification equipment (beyond dehumidification that occurs as part of the normal cooling process for schools equipped with cooling equipment). Thus, as we ventilate more in early fall and spring, Ontario schools may be hotter and more humid inside. This is a challenge primarily from a comfort perspective and decades of research have linked poor student thermal comfort to increased absenteeism, diminished cognitive function, and poorer learning outcomes (e.g., standardized test scores). There is also some evidence of increased probability of viral survivability at relative humidities above 60%. A bigger concern around humidity is during the colder months (most of the school year in most of Ontario) when schools are heated. Heating air makes it relatively drier. As relative humidities decrease, students and staff become more susceptible to respiratory diseases including the common cold, influenza, and COVID-19. An additional problem is that as relative humidities increase, particles and droplets that contain the SARS-CoV-2 RNA travel further because they become smaller as water evaporates into the drier air. This complicates any assessment of physical distancing because it increases the distance that droplets will travel before they settle and it also increases the likelihood that a droplet or particle that contains the infectious virus will bypass a mask and be breathed in by a child. The range of 40-60% relative humidity is selected to minimize these impacts. Thus, humidity provides a challenge to increasing ventilation, even if conditioning capacity is available.

18. Some Ontario schools are located in environments where ambient air quality is poor some or all of the year and/or are located near pollution sources such as major roadways, industrial sources of air pollution, some types of construction activities, and some types of agricultural activities. Increasing ventilation will increase the indoor concentration of these outdoor contaminants. Decades of research have demonstrated that poor ambient air quality is linked to a variety of negative outcomes in schools (e.g., diminished cognitive function, absenteeism, reduced academic performance) as well as specific health outcomes (e.g., increased asthma frequency and severity) and thus outdoor air quality can impose another practical limit on ventilation increases.
19. Thus, the challenge with ventilation for mitigating COVID-19 risk is that the amount of increase is going to be limited by school factors (location, weather, time of year) and HVAC system factors (available conditioning and fan capacity, type and existence of ventilation system). Despite the likely diversity of schools or contexts, we know that meeting ASHRAE Standard 62.1 minimum ventilation amounts is an appropriate starting point. Any space in a school that does not meet these guidelines should not be used without further risk mitigation measures. From this starting point, we should increase ventilation as much as possible, where possible is explicitly described by the comfort, humidity, and other constraints described in the ASHRAE School Reopening standards, checklists, and recommendations described in the responses to Questions 4 and 5. We should view increasing ventilation as a continuous way to improve risk reduction as we know when ventilation rates become very high, we are functionally in an outdoor environment where disease transmission has been documented to be very low.
20. Once ventilation is increased as much as possible beyond the ASHRAE Standard 62.1 minimum ventilation rates for the space, it is appropriate to improve filtration. This is particularly true when ventilation can't be improved beyond the minimum rates because of some of the constraints discussed above. The ASHRAE guidelines suggest the use of minimum efficiency reporting value (MERV) 13 or better filters as described by from ASHRAE Standard 52.2 in central systems and provides further guidance on how they should be installed and maintained. In some buildings, filtration may not be possible

without substantial system modification because the filter pressure drop can diminish system air flow and impact ventilation and conditioning performance. The ideal scenario would be to improve the system to accommodate MERV 13 (or better filters), but where this is not possible, portable HEPA filters can be deployed in classrooms and other school spaces. There is no direct sizing information on these filters for SARS-CoV-2, but information from other infectious diseases suggest that the air cleaner(s) should process six room volumes of air per hour (what is commonly called 6 air changes per hour). Other approaches, such as upper-room or in-duct ultraviolet systems can be used, but are not generally recommended in environments like schools where maintenance of more esoteric HVAC components can be an important limitation.

21. An open question is whether a space that cannot meet the ASHRAE Standard 62.1 minimum ventilation rates can achieve equivalent risk reduction with central filtration, portable filtration, and/or UV systems. The literature does not address this completely enough to provide an evidence-based answer, but common sense suggests that cleaning the air is better than not. We also know that poor ventilation leads to a variety of negative health and academic performance outcomes, and so these spaces should be addressed in any case.
  
22. Another common approach when mechanical ventilation is not possible is to open windows, if available. Opening windows results in increased ventilation, but it is also uncontrolled in amount. Windows also offer no ability for air conditioning and thus comfort, outdoor air pollutant, and humidity issues can also be a concern when windows are open as well as potential noise, safety and security concerns. Thus, solely from a COVID-19 risk mitigation perspective, natural ventilation from open windows should certainly be done if possible, but this should not be a primary measure if mechanical ventilation is available. Further, it is not always possible or feasible to naturally ventilate in many Ontario classrooms because of weather, condition of the windows, location of the school, and (obviously) whether operable windows exist at all. There is also the possibility of cross contamination (ventilation exhaust air being re-entrained through an

open window) and room depressurization that could draw particles from corridors, other classrooms, and bathrooms; these potential issues are very school and time dependent and cannot be easily generalized but further suggest mechanical ventilation alternatives if available.

iii. **Please contrast masking with other engineering controls in terms of their impact as a measure to prevent the transmission of COVID-19 in public schools in Ontario?**

23. There is a well-established hierarchy of controls for occupational settings shown in Figure 2 which offers some insight for schools. It is well-acknowledged that the best approach is a layered approach as no one layer in the hierarchy is likely to be completely effective all of the time. Masks serve as an important component of this integrated multi-layered approach, as well as the challenges with relying on any one approach. Public health advice on the benefit of masking for SARS-CoV-2 is generally consistent and is well supported by a variety of data from a variety of environments. In this context, masks have two roles in the hierarchy of controls for schools. Masks as protective equipment (the PPE layer) likely offer some, but also likely relatively little protection, to students and staff in schools. In order for a mask to effectively protect the wearer, the mask has to have a high filtration efficiency for the droplets/particles that contain the virus and the fit of the mask to the face has to be tight such that air goes through the mask filtration material and not around it. In the hands of properly trained workers (most investigations have focussed on healthcare workers), masks such as N95 respirators have been shown to be enormously beneficial in reducing risk. However, if the mask does not fit well, protective ability is much smaller, and in some cases almost non-existent. The benefit of cloth and other “non-medical” masks is accordingly much smaller but does offer a small amount of protection if fit properly and worn well and continuously. Thus, any PPE value of masks is likely small in schools. Masks also can be considered an engineering control because they protect others from the emissions of an infected individual. Similar to the PPE case, the details of mask efficiency and fit are important here, but they are less important because the particles/droplets tend to be larger (easy to filter) and at higher velocity (more likely to be filtered) when they are exhaled than when



they are inhaled. Most investigations show a considerably higher benefit from masks as an engineering control than as PPE. However, universal masking is a valuable but imperfect engineering control. The first issue is people cannot wear masks all the time. Eating and drinking, which need to happen schools and can often happen at the same time in a classroom, are one obvious example of this. A second issue is mask compliance: one only has to go to a grocery store to see people wearing masks improperly (e.g., below the nose) which can partially or completely defeat their value as an engineering control. In the context of a school, this introduces an issue of mask wearing compliance which is challenging to monitor continuously in any real classroom environment. A third issue is mask efficacy because mask and mask fit issues strongly impact the value of masks as an engineering control, and there is no practical in-situ test of mask efficacy, it is a partial engineering control. The fourth issue for masks in schools is the obvious issue that getting some students to wear masks, for example young children or children with some behavioural issues, is extremely difficult.

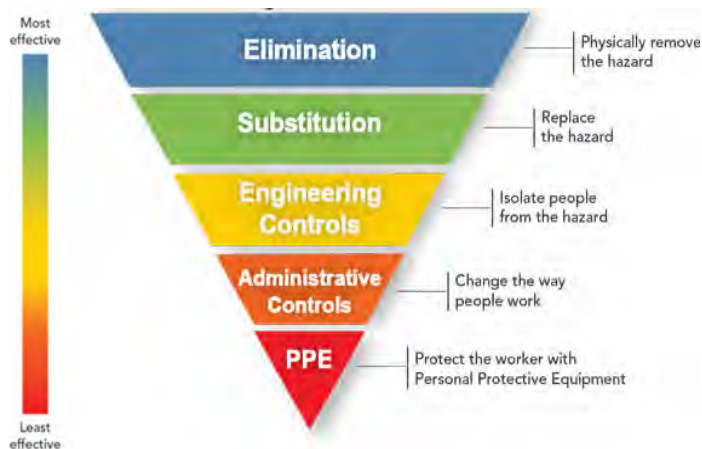

**Figure 2: The hierarchy of controls for occupational hazards from <https://www.cdc.gov/niosh/topics/hierarchy/default.html>).**

24. Despite their limitations, masks are a valuable engineering control because when they work, they are source control. Source control is well established as the best way to address any indoor air quality problem. However, owing to the potential limitations of

masks discussed above, we need other engineering controls because this layer is likely the most effective layer in the hierarchy that is readily available in schools. Elimination would require perfect, complete, and rapid testing of all students and staff and we are very far from all three of these ideals (although even imperfect, incomplete, and slower testing has value, just not as a complete layer). Physical distancing is another important component of elimination, but it again is imperfect because of long distances that infective droplets can travel indoors (discussed below in response to Question 2) , Substitution isn't readily available for in-person instruction, and so the most effective layer with the opportunity for high efficacy is engineering controls. In addition to source control (e.g., masking as well as handwashing and surface cleaning), the two other main approaches used to maintain indoor air quality are ventilation and filtration/air cleaning. These are discussed through this document. The most complete engineering approach for a school would address all three of these controls approaches to address the efficacy and completeness of each individual approach. And further, engineering controls are part of a larger suite of measures, as discussed in Question 2.

- iv. **In your opinion, how should the measures referenced in (2) and (3) be prioritized to mitigate risk of COVID-19 transmission in public schools in Ontario? What measures, if any, can be adopted in the short-term to reduce risk given that many schools are re-opening on or before September 8, 2020?**

25. The best answer to this question is that Ontario schools should follow the standards, checklists, and recommendations in the ASHRAE Schools Reopening document discussed below in the responses to Questions 5 and 6 for all HVAC issues. There is considerably more nuance in the documents, but they can be briefly summarized as:

- Make sure that all spaces in the school meet the appropriate minimum ventilation guidelines from ASHRAE Standard 62.1-2019. Change the use of these spaces if they do not meet these guidelines
- Increase ventilation as much as possible above the minimum guidelines in all school spaces where the limits of what is possible may be dictated by thermal comfort, humidity, and/or outdoor air quality limitations.

- At times where ventilation cannot be increased above minimum guidelines, use properly installed and maintained MERV 13 filters in central systems to treat all recirculated air and/or portable HEPA filters in all spaces.
- Maintain all HVAC systems to ensure that they are providing as much ventilation and conditioned air as possible to school spaces.
- Invest in school HVAC systems, particularly in schools with marginal HVAC systems, so that they can provide increased ventilation air.

26. Globally main school boards are have developed simplified flowchart approaches for these measures. One example is shown below in Figure 3 from the Yale School of Public Health. Such simplified graphical approaches can be a clear approach to rapidly deploy measures in schools.

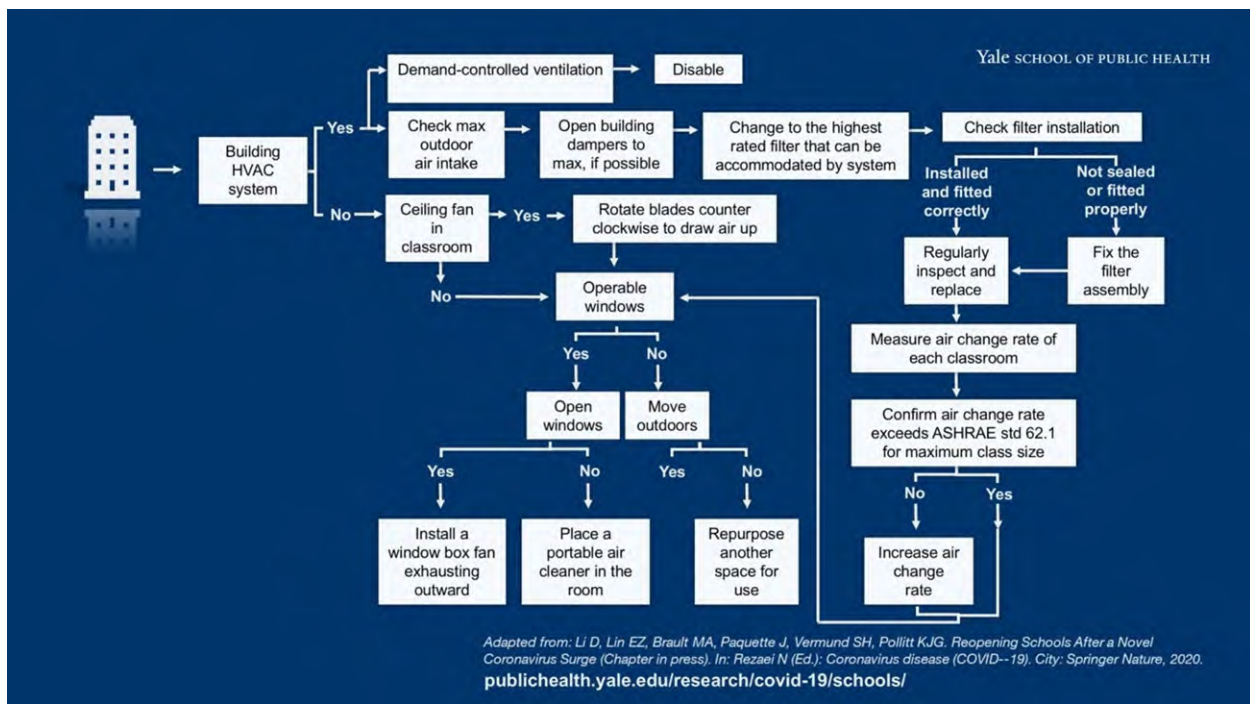

Figure 3: Simplified flow chart for HVAC and building control measures from <https://publichealth.yale.edu/research/covid-19/schools/ventilation/>.

- v. **Please describe the standards, checklists, and recommendations set out in “Reopening of Schools and Universities” published by the American Society of Heating, Refrigerating and Air-Conditioning Engineers (ASHRAE), and describe how they were formulated. Please**

describe how these standards, checklists, and recommendations can be applied to all public schools in Ontario.

27. Among other activities, ASHRAE “writes standards and guidelines in its fields of expertise to guide industry in the delivery of goods and services to the public”. ASHRAE standards follow a documented procedure that includes a committee of experts appointed by the society following guidelines about balance and representation, a consensus and voting process, public review, society approval, and (often) continuous maintenance of the standard. This is a time consuming process that does not lend itself to emerging and urgent issues.
28. In response to the COVID-19 pandemic on March 31, 2020 ASHRAE established an Epidemic Task Force (ETF) with several responsibilities including “Reviewing, organizing, consolidating and publishing clear and concise summaries with citations of the most relevant information available to the built environment.” The ETF produces and updates documents on a variety of topics, including general guidance for all buildings. These reports are intended as guidance documents and are organized around specific themes including building readiness and building guides (see Figure 4, below)

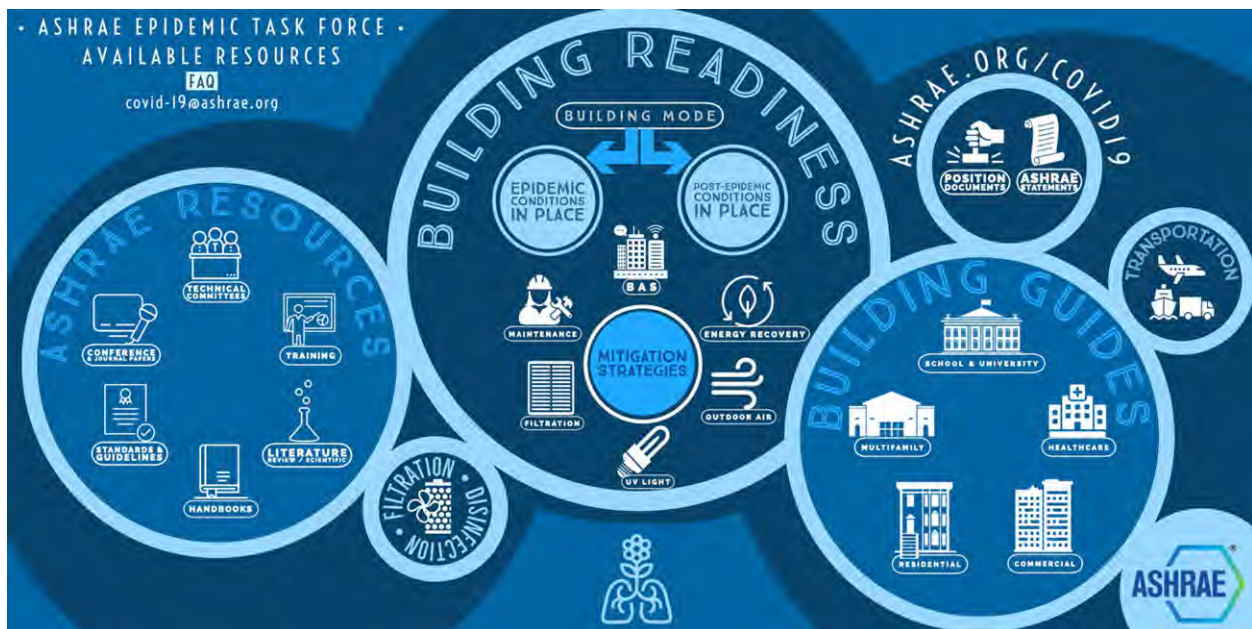

Figure 4: ASHRAE COVID-19 Infographic from

<https://www.ashrae.org/file%20library/technical%20resources/covid-19/ashrae-covid19-infographic-.pdf>.

29. The ASHRAE ETF also publishes specific standards, checklists, and recommendations for reopening of schools and universities, attached at Tab 5 of Appendix A, that is intended to further provide guidance to assist education decision makers and maintenance personnel on topics specific to schools and universities. The guide has many elements including checklists, design and operation guidelines, ventilation and filtration information, as well as information about specific spaces within schools and universities (e.g., nurses offices). The guide is written to be adapted to local contexts and “should be applied to each unique climate zone, unique school building and HVAC system. All retrofits and modifications must not contradict ASHRAE 62.1 guidelines and must continue to [meet] or exceed the standards and codes adopted by local jurisdictions.”

30. Of particular relevance to this report are about ventilation and filtration. From the preoccupancy checklist (note, [] indicate textual changes from the ASHRAE document):

- Maintain proper indoor air temperature and humidity to maintain human comfort, reduce potential for spread of airborne pathogens
- Review outdoor airflow rates compared to the most current version of ASHRAE Standard 62.1 or current state-adopted code requirements.

And further in the section about designing new and modifying existing school HVAC systems

- Follow current ASHRAE 62 standard or local ventilation standards for minimum outside air requirements.
- For remodeling an existing AHU, increase outside air to maximum allowable per Air Handling Unit (AHU) without compromising indoor thermal comfort for learning environment (due to severe thermal outdoor air conditions) or space IAQ due to poor outdoor ambient conditions (pollution).

- During the Pandemic, disable any Demand Control Ventilation (DCV) and introduce the maximum possible [Outdoor Air] OA flow 24/7 until further notice (including [dedicated outdoor air system] DOAS).

There is similar information on filtration:

- Apply the highest Minimum Efficiency Reporting Value (MERV) applicable for the HVAC units (local, central and DOAS). MERV 13 is recommended minimum if equipment can accommodate pressure drop and MERV 14 is preferred
- Introduce portable, all electric HEPA/UV [air cleaners] s in each classroom
  - Guideline minimum of 2 Air rotations/hour [ACH]
  - Ensure flow patterns maximize mixing of air in classrooms

31. The general building readiness guidance information and the schools-specific information are designed to be adopted to any building. The ETF information does not, in general, provide target levels for quantities (e.g., ventilation rates per person, with the exception of affirming that ASHRAE Standard 62.1 is the minimum ventilation rate ) that would limit the application for some climates or for some types of HVAC systems, but instead provides process and approaches that can be applied to any building. For any given goal, there are often multiple approaches that can be considered by decision-makers (often in consultation with an HVAC professional) to select the approaches that are possible for a specific school/space within a school. Further, there is explicit guidance on HVAC upgrades so that schools that are investing in their systems can select improvements for consideration that make sense for their context. Thus, the ASHRAE ETF guidance is appropriate for any school in Ontario because the guidance is designed to be adaptable to any specific building/context.

- vi. **In your opinion, would adopting the ASHRAE standards, checklists, and recommendations in schools in Ontario reduce the risk of transmitting COVID-19 upon re-opening? If yes, why and to what extent?**

32. There is overwhelming evidence from other respiratory infectious diseases and clear emerging data on SARS-CoV-2 that a well-considered and well-implemented approach of engineering controls will reduce the risk of infectious disease transmission in schools. The standards, checklists, and recommendations provided in the ASHRAE reopening document are consistent with the evidence in reducing infectious disease transmission, consistent with information provided by public health authorities and other relevant organizations, and are meant to be implemented as part of a broader series of controls as described above.
33. The ASHRAE guidance, standards, and checklists provide a roadmap and strategies that can be used for adding layers of engineering controls. The specific benefits are correcting airborne disease transmission risk because of insufficient ventilation, reducing airborne infectious disease risk by increasing ventilation above minimums for acceptable indoor air quality (e.g., Standard 62.1 minimum ventilation rates), adding appropriately selected, installed, and maintained central and portable filtration to remove the SARS-CoV-2 from recirculating and room air, particularly when ventilation cannot be increased beyond adequate levels, addressing ventilation and isolation for speciality spaces in schools that can be used for symptomatic students (e.g., nurses offices, wellness rooms), a framework to consider more advanced options (e.g., upper-room and in-duct UV systems) for higher risk environments, etc. A key strength of the ASHRAE standards is the balance between practicality and a framework to follow (e.g., checklists) and the flexibility to adapt the material to different Ontario schools with different HVAC systems, in different climates, at different times of the year, with different indoor spaces, and that serve different student populations.
34. The question of extent of reduction is not well understood by current science, particularly for SARS-CoV-2. There are several reasons for this, but the big factors are that there are no specific studies of school reopening that are contextually similar enough to Ontario to draw direct parallels, the emphasis in every jurisdiction has been on the practical matters associated with school reopening and not on the scientific investigation, and that even if there was a way to do scientific investigation, it would be unethical because the control

group of students without these controls would have to be subject to an environment that we know increases the transmission of infectious disease.

vii. **Please provide your opinion on whether the Ministry of Education’s Memo #B12 entitled: “Optimizing Air Quality in Schools”, outlines sufficient measures pertaining to heating, ventilation, and air conditioning to mitigate the risk of COVID-19 transmission in public schools in Ontario? Why or why not?**

35. A first comment about the Ministry of Education’s Memo #B12 (hereafter referred to as the Ministry Memo in this report) is that it shares content, language, structure similarities with the ASHRAE School Reopening standards, checklists, and recommendations discussed above in the responses to Questions 6 and 7. It seems likely that there was a common original reference source, or one document borrowed from the other. This is important to point out because there is clear commonality in the issues addressed. The ministry document, however, has insufficient specificity and detail to meaningfully reduce COVID-19 transmission in schools and also includes some inaccuracies and omissions that would further limit its value in mitigating COVID-19 risk. The central issues and examples are provided below.

36. The Ministry Memo Appendix A is correct to acknowledge the importance of ventilation and other building level engineering controls to reduce the transmission of COVID-19. However, it is insufficient and incomplete in the information that it provides. The biggest omission is that there is no acknowledgement of providing a minimum level of ventilation rate (as per ASHRAE Standard 62.1 or similar). Instead, examples statements about ventilation generally are more cryptic such as the following: “Reviewing and optimizing the outdoor air ratio of HVAC systems as much as possible.” This approach doesn’t list a standard for review and, even more importantly, a standard for optimization. Ventilation in a school could be optimized for any number of factors (e.g., comfort, energy use, system wear) that have little or no relevance for infectious disease transmission. The specific advice on mechanic ventilation is better: “Assess air supply (review outdoor air ventilation rate and increase where possible, adjust/optimize demand



control ventilation if required and as much as practically feasible to increase outdoor/fresh air),” but again there is no stated standard for review or comparison, no indication what to do if minimum guidelines are not met, and no indication of what to do if it is not practically possible to increase ventilation. The specific advice on natural ventilation: “open windows, if safe to do so (assess to prevent re-entry of building exhaust)” does not address any of the potential comfort, noise, outdoor air pollution and unknown ventilation amount challenges with open windows discussed above in response to Question 2.

37. The filtration measures in Appendix A are similarly vague and incomplete. There is no specified central filtration level (in contrast to the MERV 13 Standard in the ASHRAE reopening standards, checklists, and recommendations), many vague statements like “improve central air” and recommendations that don’t have an indication of what to do with the outcome of the measure (e.g., “Check that sufficient airflow can be maintained based on HVAC design criteria”). This is a particularly important issue as lower efficiency filters (or poorly installed higher efficiency filters) are not capable of removing very many particles/droplets that contain the SARS-CoV-2 virus and thus can provide very limited or no risk mitigation benefits.
38. Similarly for portable filtration, the recommendation is to consider such devices “where ventilation is insufficient or where outdoor/fresh air introduction cannot be achieved by other means” with no indication of what sufficient ventilation is and no guidance on types of air cleaners other than “such devices and their placement should be carefully selected” and thus does not provide any actionable guidance. A school could follow these guidelines and install a portable ionizer or other unproven technology that would have little or no impact on disease transmission and could potentially introduce ozone and harmful byproducts in the space.
39. There are also technical errors in Appendix A that suggests that it was not reviewed by those with technical expertise on engineering controls. There is often a germ of truth, but not applied to the correct system or omitting key material. An example from the

ventilation material “If practical or possible, bypass energy recovery ventilation systems that recirculate/mix exhaust air back into the outdoor air supply.” Energy recovery systems are defined by ASHRAE as a “heat exchanger assembly for transferring heat between two isolated fluid sources. The recovery system may be of air-to-air design or a closed loop hydronic system design. The system will include all necessary equipment such as fans and pumps, associated ducts or piping and all controls (operating and safety), and other custom-designed features.” These systems deliberately do not mix exhaust air and supply air but instead exchange energy between the streams. Although there is a small amount of leakage between the streams with some energy recovery systems, it is by no means ubiquitous and further there is no evidence of the literature of this happening with particles of size relevance to SARS-CoV-2 containing particles and droplets (where it is an issue, it is an issue for gases and not particles) or implicated in any infectious disease transmission. Recirculation of air in HVAC systems is something entirely different and a very common aspect where some amount of air is recirculated to minimize the energy consequences of ventilation (see Response to Question 1). This is completely separate from energy recovery systems. An example of an omission error from the filtration section is a statement like the “Consider using pleated filters to increase filtration surface area.” Pleating of filters is common among many filter styles and is not an appropriate (or even remotely definitive) marker for higher efficiency. An example accuracy error from the section on portable filters is the recommendation to ensure “intake is not directly from the floor”. This is the exact opposite of a problem with some portable filters that have high **outflow** near the floor they can resuspend particles that have previously deposited on the floor, potentially including those that have infectious virus, and spread those in the room. Intake from the floor can be desirable because the resuspended particles are immediately filtered. The concern with incomplete, misleading, inaccurate information is that a user following this guidance could invest resources with the goal of reducing infectious disease transmission and not achieve this goal, not have any indication of effectiveness, and potentially cause secondary harms.

Appendix B of the memo presents example checklists that have many of the same concerns as raised for Appendix A. The table below shows example checklist items and their comparison to checklists in the ASHRAE reopening documents that illustrate issues:

Ministry Memo Checklist Item(s)	ASHRAE Reopening Document Checklist Item(s)	Summary of issue with Memo item(s)
If Demand-Controlled Ventilation (DCV) systems using Carbon Dioxide (CO <sub>2</sub> ) sensors are installed, trend and monitor on an ongoing basis.	If Demand-Controlled Ventilation (DCV) systems using Carbon Dioxide (CO <sub>2</sub> ) sensors are installed, operate systems to maintain maximum CO <sub>2</sub> concentrations of 800-1,000 Parts Per Million (ppm) in occupied spaces	What action should be taken based on trending and monitoring? What standards for CO <sub>2</sub> concentration should be met?
Verify filtration in all mechanical equipment: verify filters installed correctly and are being maintained.	Select filtration levels (MERV ratings) that are maximized for equipment capabilities, use MERV 13 if equipment allows, while assuring the pressure drop is less than the fans capability. See Filtration Upgrades.  Verify filters are installed correctly.  Develop standards for frequency of filter replacement and type of filters to be utilized.	The first part of memo checklist item appears to imply that check on the existence of filters and says nothing about the suggested level of filtration efficiency, the second part provides no specific guidance on maintenance. Further ASHRAE recommendations tie to specific information elsewhere in the document about correct installation.
Maintain proper indoor air temperature to maintain human comfort.	Maintain proper indoor air temperature and humidity to maintain human comfort, reduce potential for spread of airborne pathogens and limit potential for mold growth in building structure and finishes (refer to ASHRAE Standard 55, recommended temperature ranges of 68-78 degrees F dry bulb depending on	Temperature is only one aspect of comfort and there is no indication of what “proper” means, how temperature should be measured, and how temperature data should be evaluated. Impact of environmental conditions (especially humidity) on disease transmission is ignored.

	<p>operating condition and other factors, recommend limiting maximum RH to 60%). Consider consulting with a local professional engineer to determine appropriate minimum RH levels based on local climate conditions, type of construction and age of the building under consideration. Recommend minimum RH of 40% if appropriate for building. Consider the addition of humidification equipment only when reviewed by a design professional to verify minimum RH set points will not adversely impact building or occupants by contributing to condensation and possible biological growth in building envelope. Trend and monitor temperature and humidity levels in each space to the extent possible and within the capability of BAS, portable data loggers and handheld instruments.</p>	
--	--	--

46. Thus appendix B of the Ministry Memo does not provide actionable guidance such that the risk of COVID-19 is addressed. The last part of the Ministry Memo, Appendix C provides three eligible items for expenses. Ventilation system improvements/additions, a key evidence-based aspect of infectious disease transmission risk reduction, are not mentioned at all. Optimizing air circulation and pressure, are mentioned – as with previous examples it isn’t clear how or what should be valued in the optimization and although air circulation and building pressures can be important, they are much less important than providing ventilation air as discussed elsewhere in the Ministry Memo (and in the ASHRAE Reopening documents).

47. In summary, the Ministry Memo does not provide detailed, specific, actionable, and accurate information that would allow a decision-maker at a school to meaningfully reduce the risk transmission associated with infectious disease. Given the correspondence of some language (e.g., some items in the checklists) in the Ministry Memo with those in the ASHRAE Reopening documents, it seems likely that the Ministry Memo could be easily substituted with the ASHRAE Reopening document to correct the deficiencies and omissions in the Ministry Memo.

# **APPENDIX A**

**Jeffrey A. Siegel, Ph.D.**

*Professor, Department of Civil and Mineral Engineering  
The University of Toronto*

---

**EDUCATION**

University of California, Berkeley	Mechanical Engineering	Ph.D.	2002
University of California, Berkeley	Mechanical Engineering	M.S.	1999
Swarthmore College	Engineering	B.S.	1995

**ACADEMIC EXPERIENCE**

*The University of Toronto, Department of Civil and Mineral Engineering*

Professor – 7/2015 - present

Associate Professor – 1/2013 to 6/2015

*The University of Toronto, School of Public Health (non-budgetary cross appointment)*

Professor – 9/2014 to present

*The University of Toronto Department of Physical and Environmental Sciences (non-budgetary cross appointment)*

Professor – 9/2015 to present

*The University of Texas at Austin, Department of Civil, Architectural, and Environmental Engineering*

Associate Professor – 9/2008 to 12/2012

Assistant Professor – 8/2002 to 8/2008

**COURSES TAUGHT (University of Toronto)**

CIV 1320: Indoor Air Quality, CIV 576 Sustainable Buildings, CIV 380 Sustainable Energy Systems

**COURSES TAUGHT (University of Texas)**

ARE389T: Indoor Air Quality: Transport and Control, ARE370: Design of Energy Efficient and Healthy Buildings, ARE346N Building Environmental Systems, ARE346P: HVAC Design, ARE383 Advanced Sustainable Buildings, CE383 Indoor Environmental Quality Measurements

**GRADUATED STUDENTS (University of Toronto)**

---

<b>Student Name<sup>1</sup></b>	<b>Degree</b>	<b>Year</b>	<b>Thesis Title</b>
Yizhi (Annabel) Zhang	MASc	2020	Indoor particle concentrations and filter impacts
Masih Alavy	PhD	2019	In-Situ Measurement of Ventilation and Impacts of Filtration on IEQ and Energy Use of Residential Buildings
Enersto Diaz Lozano Patiño	MASc	2018	Indoor Environmental Quality in Social Housing: review, thermal comfort and odour control
Claire Lepine*	MPH	2017	What do residents know about their homes?
Phil Fan	MASc	2017	Moisture wetting dynamics on gypsum drywall
Shaimaa Seyam	MASc	2017	Impact of plants on indoor air quality
Daniel Haaland	MASc	2016	Quantitative filter forensics
Mahnaz Zare	MASc	2015	The Building Science of Office Surfaces: Implications For Microbial Community Succession
Sandra Dedesko	MASc	2015	Indoor Environmental Measurements in the Hospital Microbiome Project: Estimation of human occupancy and occupant activity

**GRADUATED STUDENTS (University of Texas)**

---

<b>Student Name<sup>1</sup></b>	<b>Degree</b>	<b>Program<sup>2</sup></b>	<b>Year</b>	<b>Dissertation/Thesis Title</b>
---------------------------------	---------------	----------------------------	-------------	----------------------------------

Shahana Khurshid*	Ph.D.	EWRE	2015	Particulate Reactive Oxygen Species In Indoor And Outdoor Environments: Prevalence and health effects
Elena Nirlo*	Ph.D.	EWRE	2014	Assessing and Controlling Concentrations of Volatile Organic Compounds in the Retail Environment
Marwa Zaatari* (formerly Farhat)	Ph.D.	BEE	2013	Pollutant Control Strategies for Acceptable Indoor Air Quality and Energy Efficiency in Retail Buildings
Elliott Gall*	Ph.D.	EWRE	2013	Ozone transport to and removal in porous materials with applications for low-energy indoor air purification
Andrew Hoisington*	Ph.D.	EWRE	2013	The bacterial and fungal microbiome of retail stores
Sarah Taylor-Lange*	Ph.D.	SEM	2013	Advancements in concrete material sustainability: supplementary cementitious material development and pollutant interaction
Brent Stephens	Ph.D.	EWRE	2012	Characterizing the impacts of air-conditioning systems, filters, and building envelopes on exposures to indoor pollutants and energy consumption in residential and light-commercial buildings
Megan Gunther	M.S.	BEE	2011	Ozone Emission from In-duct Air Cleaners
Joshua Rhodes	M.S.	BEE	2011	Indoor Air Quality in Retail Environments
David Kauffman	M.S.	BEE	2010	Control of residential economizers for energy efficiency Improvements
Diana Hun*	Ph.D.	BEE	2010	Exposure to Hazardous Air Pollutants in Homes
Federico Noris*	Ph.D.	EWRE	2010	Biological and Chemical Analysis of HVAC Filters
Clement Cros*	M.S.	EWRE	2010	Aging and effectiveness of passive removal materials
Elliott Gall*	M.S.	EWRE	2009	Primary And Secondary Emissions From Green Building Materials: Large Chamber Experiments
Michael Waring	Ph.D.	EWRE	2009	Indoor Secondary Organic Aerosol Formation: Influence of Particle Controls, Mixtures, and Surfaces
Brent Stephens	M.S.	EWRE	2009	Energy Implications of Filters in Residential and Light – Commercial HVAC Systems
Catherine Mukai*	M.S.	EWRE	2008	Impact of Airflow Characteristics on Particle Resuspension from Indoor Surfaces
Donna Kunkel*	M.S.	EWRE	2008	Passive removal of ozone from indoor environments
Mark Sanders	Ph.D.	BEE	2008	Assessment of Indoor Air Quality in Texas Elementary Schools
Francois Levy	M.S.	BEE	2008	Indoor Air Quality Challenges in Lunar Habitats
Gabriel Shelton*	M.S.	EWRE	2007	Investigation into Parameters Affecting Ozone Removal in HVAC Filters



James Lohaus	Ph.D.	EWRE	2007	Particle Resuspension from Indoor Flooring Materials
Ping Zhao*	Ph.D.	EWRE	2006	Ozone Interactions with HVAC Filters
Michael Waring	M.S.	EWRE	2006	Smoking Bans as Particle Source Control and HVAC Component Loading due to Airborne Particle Mass Deposition
Joseph Fradella	M.S.	CEPM	2006	Particle transport in buildings during extraordinary events
Xiaorui Yu	M.S.	CEPM	2005	Critical Review and Experimental Study of Portable Ion Generators as Indoor Air Cleaning Devices
Matthew Ward*	M.S.	EWRE	2005	Indoor Particle Control: Portable Air Cleaners, HVAC Filter Bypass, and Shelter-In-Place
James Lo	M.S.	BEE	2005	Integrated Device Control for Residential HVAC Load Reduction
Christopher Krus	M.S.	CEPM	2004	Lifecycle costing of hospital HVAC systems
Sachin Goel	M.S.	CEPM	2004	Overview of the research efforts in automating the procedure of creating site layout on a construction project

<sup>1</sup>\* = co-advised, Nirlo and Zaatari were not co-advised until move to UofT in January 2013.

<sup>2</sup>EWRE = Environmental and water resources engineering, BEE = Building energy and environments (formerly Architectural engineering, ARE), CEPM = Construction engineering and project management, SEM = Structural and engineering materials

#### **STUDENTS IN PROGRESS (*University of Toronto*)**

<b>Student Name<sup>1</sup></b>	<b>Degree</b>	<b>Expected<sup>3</sup></b>	<b>Thesis Topic</b>
Tianyuan (Amy) Li	Ph.D.	Fall 2021	Residential filtration performance and health impacts
Donna Vakalis*	Ph.D.	Fall 2020	IEQ in schools and social housing
Alireza Mahdavi	Ph.D.	Fall 2020	Chemical and physical analysis of filter dust
Yuchao Wan <sup>†</sup>	Ph.D.	Fall 2020	SVOCs in indoor and filter dust
Bowen Du	Ph.D.	Spring 2022	IAQ impacts on cognitive function

\* = co-advised with Heather MacLean, <sup>†</sup> = co-advised with Miriam Diamond

#### **Supported Post-Doctoral Fellows (*University of Toronto*)**

<b>PDF Name<sup>1</sup></b>	<b>Years</b>	<b>Research Topic</b>
Dr. Raheleh Givehchi	2017-present	Indoor nanoparticles and filtration
Dr. Marianne Touchie*	2014-2015	Residential HVAC characterization

\*part-time

Served/serving on approximately 55 additional M.S. and Ph.D. committees

Advised 6 additional MS coursework only students and approximately 35 undergraduate research assistants Advise approximately 6 undergraduate students/year.

#### **AWARDS**

- Young et al. (2019) selected for *Environmental Science: Processes & Impacts* Best Papers Collection (2020)
- ASHRAE Fellow (2017-)
- Member of International Society of Indoor Air Quality and Climate Academy of Fellows (2016-)
- 2010 ASHRAE Transactions Paper Award, with Michael Waring (2011)

- J. Neils Thompson Centennial Teaching Fellow in Civil Engineering (2010-2012)
- National Academy of Engineering Frontiers of Engineering Education Symposium (2010)
- Student Engineering Council Departmental Favorite Professor Award (2008)
- College of Engineering Outstanding Teaching by an Assistant Professor (2007)
- Innovative Instructional Technology Awards Program (IITAP) Gold Medal (2007)
- Award for Innovative Excellence in Teaching, Learning and Technology from the International Conference on College Teaching and Learning (2007)
- 3M Non-tenured Faculty Award (2006, 2007, 2008)
- ASHRAE New Investigator Award (2006, 2007)
- International Society for Exposure Assessment Early Career Award (2004-2007)

**ACADEMIC SERVICE (*University of Toronto*)**

---

FASE Department of Civil and Mineral Engineering Chair	2018
Review committee	
Building Science MEng Specialization Coordinator	2016-present
Department search committee for urban sustainability position	2016-2017
Department search committee for FASE Interdisciplinary position	2015-2016
Graduate Attributes Committee	2013-2015 (chair)
Coordinator of Building Section	Sept. 2014-present
Teaching evaluation committees for four assistant professors	October 2014-present
Search committee for Daniels School of Architecture	March 2014-July 2014

---

**ACADEMIC SERVICE (*University of Texas*)**

---

<b>Committee Name<sup>1</sup></b>	<b>Years of Service</b>
Graduate Curricula and Policies Committee	2010-2012
	2011-2012 (chair)
Assistant graduate advisor	2009-2012
BEE Graduate Admissions Committee	2003-2012 (chair)
EWRE Graduate Admissions Committee	2003-2012
Graduate Fellowships, Financial Aid, and Recruiting Committee	2009-2010
External Advisory Committee Liaison Committee	2007-2010
Advisor Phi Alpha Epsilon (Arch. Engineering Honor Society)	2007-2009
Ad hoc Web Site Committee	2007-2009
ARE/Cluster Hire Faculty Search Committee	2007-2008, 2009
CAEE Chair Review Committee (CSoE Committee)	2005-2006
ARE Faculty Search Committee	2004-2005
Undergraduate Recruiting and Retention Committee	2003-2012
	2003-2007
Distinguished Lecture Committee	2005-2007 (chair)
Technical Staff Committee	2002-2003
Special Awards Committee	2002-2004

---

<sup>1</sup>CAEE = Department of Civil, Architectural, and Environmental Engineering, ARE = Architectural Engineering, BEE = Building energy and environments, EWRE = Environmental water and resources engineering, CSoE = Cockrell School of Engineering

**PROFESSIONAL SERVICE**

- Member of ASHRAE Indoor Air Quality Position Document Committee

- Member of authoring committee of AHA document entitled “Personal Measures to Mitigate Air Pollution Mediated Cardiovascular Risk”
- Associate Editor of *Building and Environment* Journal (2015-2019)
- Track lead for Air Cleaning and Filtration Track at Indoor Air 2018 (Philadelphia, PA)
- Member of International Scientific Committee for IAQVEC 2016 (Seoul)
- Co-Organizer of Microbiome of the Build Environment Annex Workshop at Indoor Air 2016 (Ghent)
- Member of Scientific Committee for Healthy Buildings USA 2015 (Boulder, CO)
- Member of International Scientific Committee for Indoor Air 2014 (Hong Kong)
- Presented keynote talk on air filtration at Indoor Air 2014
- Member of Steering Committee for ASHRAE IAQ 2013 (Vancouver, BC)
- Member of Organizing Committee for Indoor Air 2011 (Austin, TX)
- Voting member American Society of Heating, Refrigeration, and Air-Conditioning Engineers (ASHRAE) TC 2.4: Particulate Air Contaminants and Removal Equipment (2004-2008, 2009-2013). Research Subcommittee Chair (2004-2009), Secretary (2017-2019) Vice Chair (2019-2021), Chair (2021-2023)
- Voting member ASHRAE TC 6.3: Central Forced Air Heating and Cooling Systems (2003-2010)
- Voting member ASHRAE Standard 52.2: Method of Testing General Ventilation Air-Cleaning Devices for Removal Efficiency by Particle Size (2004-2013)
- Voting member of ASHRAE Environmental Health Committee (2014-present), Research subcommittee chair (2014-present)
- Member of ASHRAE Air Filtration and Cleaning Position Document Committee
- Initiated ASHRAE branch chapter at UofT (2013) and branch advisor (2013-present)
- Indoor Aerosols and Aerosol Exposure Working Group of American Association for Aerosol Research (AAAR) (Vice Chair/Chair 2010-2012)
- Site visit for proposal evaluation for NSERC College and Community Innovation Program Technology Access Centers Grant (2014)
- Review 10-20 journal articles and grant proposals each year for ASHRAE Transactions, ASHRAE IAQ, International Journal of HVAC&R, Indoor Air, Journal of Hazardous Materials, Journal of Occupation and Environmental Hygiene, Atmospheric Environment, Building and Environment, ASCE Journal of Architectural Engineering, Aerosol Science and Technology, Environmental Science and Technology, Department of Energy, National Science Foundation, Hong Kong National Science Foundation, Journal of Aerosol Science, Health Canada, Environment Canada, Science of Total Environment, Indoor and Built Environment, NSERC, MITACs, others
- External Committee Member for dissertations at the University of British Columbia and Waterloo University
- Reviewed tenure packages for faculty at Drexel University, Missouri University of Science and Technology, University of California, Los Angeles, Illinois Institute of Technology, Dalhousie University
- Reviewed promotion and chair professor packages for Shanghai Jhao Tong University, National University of Singapore, Hong Kong City University

#### **RECENT CONSULTING ACTIVITIES**

- Consultant to Amphenol on COVID-19 and reopening
- Consultant to Alphabet (Nest) on filtration
- Consultant to iRobot on air cleaning and indoor air pollutants
- Expert witness for Donnelly Hadden plaintiff counsel for case involving ozone generator and residential damage (2013-2017)
- Consultant to Washington State University on Residential Ventilation Measurement (2013)
- Expert witness for Pattishall, McAuliffe, Newbury, Hilliard & Geraldson LLP defendant counsel for lawsuit involving vacuum cleaners and HEPA filtration (2011-2013)

- Expert witness for Michael P. Mazza, LLC plaintiff counsel for lawsuit involving intellectual property and ventilation controls (2010-2013)
- Consultant to Federal Trade Commission on ozone-emitting air cleaners (2009-2010)
- Consultant to Air Filtration Test Laboratory at the University of Illinois, Chicago on HVAC filter bypass (2007-2008)
- Consultant to Lightfoot, Franklin & White, L.L.C. plaintiff counsel for class action lawsuit on ion generating air cleaners (2006-2008)

#### **Recent EXTERNALLY FUNDED RESEARCH PROJECTS (*University of Toronto*)**

<b>Sponsor</b>	<b>Date</b>	<b>Title</b>
Tri-Agency NFRF	20/04/01-22/04/01	Exposing the Brain: The neurocognitive impacts of indoor air pollution
UofT FASE/FAS	18/09/01-20/08/31	Exceed: Neurocognitive Impacts of Indoor Pollutants
NSERC	18/04/01-19/03/31	RTI: Indoor Nanoparticles: Sources, dynamics, and control
ASHRAE	16/04/30-19/04/30	RP1649: IAQ and Energy Implications of High Efficiency Filters in Residential Buildings
Sloan Foundation	14/11/01-18/10/31	Moisture, wetting, and fungal growth
HUD <sup>1</sup>	13/11/01-16/10/31	Children's asthma triggers in rural Texas homes
Sloan Foundation <sup>1</sup>	13/11/01-19/10/31	The interaction of building science measures, pest interventions and microbiomes in the indoor environment
Sloan Foundation <sup>1</sup>	12/11/01- 14/10/31	Building Science of the Hospital Microbiome
Sloan Foundation <sup>1</sup>	13/02/01- 14/10/31	Microbial Succession on Common Office Surfaces
NSERC	14/04/01-21/03/31	Discovery: Filter forensics
CFI/ORF	14/11/01-19/10/31	Secret life of particles (Instrumentation and operating)
NSERC/OCE/ Connect Canada	14/04/01-15/07/01	Novel tracers for sub-slab ventilation system evaluation

<sup>1</sup>subcontracts to US universities.

Additional grants include symposium grant to fund microbiology of the built environment and chemistry of the indoor environment activities at Indoor Air 2016.

#### **SELECTED EXTERNALLY FUNDED RESEARCH PROJECTS (*University of Texas*)**

<b>Sponsor</b>	<b>Title &amp; Collaborators</b>
ASHRAE/ NIST	RP-1596 Ventilation and Indoor Air Quality in Retail Stores (co-PI = Srebric, PSU)
Sloan	The Microbial Community of Retail Environments (co-PI = Kinney)
CARB	In-Duct Air Cleaning Devices: Ozone Emission Rates and Test Methodology (PI = Morrison MUS&T, co-PI= Shaughnessy U. Tulsa)
NSF	IGERT: Indoor Environmental Science & Engineering – An Emerging Frontier (PI = Corsi, co-PI = Kinney)
ASHRAE	RP-1299 Energy Implications of Filters in Residential and Light Commercial Buildings

HUD = US Department of Housing and Urban Development, ASHRAE = American Society of Heating, Refrigerating and Air-Conditioning Engineers, NIST = National Institute of Standards and Technology, Sloan = Alfred P. Sloan Foundation, CARB = California Air Resources Board, NSF = National Science Foundation

#### **PEER-REVIEWED JOURNAL ARTICLES (*accepted or published*)**

97. Matava C, Collard V, Siegel J, Denning S, Li T, Du B, Fiadjoe J, Fiset P, Engelhardt T. 2020. Use of a high-flow extractor to reduce aerosol exposure in tracheal intubation. Accepted to *British Journal of Anaesthesia*. doi: 10.1016/j.bja.2020.07.014.

96. Du B, Tandoc M, Mack M, Siegel J. 2020. Indoor CO<sub>2</sub> Concentrations and Cognitive Function: A Critical Review. Accepted to *Indoor Air*.
95. Mahdavi A, Siegel JA. 2020. Extraction of Dust Collected in HVAC Filters for Quantitative Filter Forensics. Accepted to *Aerosol Science and Technology*.
94. Zhang Y, Li T, Siegel JA. 2020. Investigating the Impact of Filters on Long-term Particle Concentration Measurements in Residences (RP-1649). Accepted to *Science and Technology for the Built Environment*.
93. Haines SR, Siegel JA, Dannemiller KC. 2020. Modeling microbial growth in carpet dust exposed to diurnal variations in relative humidity using the “Time-of-Wetness”. Accepted to *Indoor Air*. DOI: <https://doi.org/10.1111/ina.12686>.
92. Vakalis D, Lepine C, MacLean HL, Siegel, JA. 2020. Can green schools influence academic performance? Accepted to *Critical Reviews in Environmental Science and Technology*. DOI: 10.1080/10643389.2020.1753631.
91. Wan Y, Diamond ML, Siegel JA. 2020. Elevated Concentrations of Semivolatile Organic Compounds in Social Housing Multiunit Residential Building Apartments. *ES&T Letters*, 7, 191-197. DOI: <https://pubs.acs.org/doi/10.1021/acs.estlett.0c00068>.
90. Li T, Siegel JA. 2020. Laboratory performance of new and used residential HVAC filters: Comparison to field results (RP-1649). *Science and Technology for the Built Environment*, 26, 844–855. DOI: 10.1080/23744731.2020.1738871.
89. Bakker A, Siegel JA, Mendell MJ, Prussin A, Marr L, Peccia J. 2020. Bacterial and fungal ecology on air conditioning cooling coils is influenced by climate and building factors. *Indoor Air*, 30, 326-334. DOI: [10.1111/ina.12632](https://doi.org/10.1111/ina.12632).
88. Li T, Siegel JA. 2020. In-situ Efficiency of Filters in Residential Central HVAC Systems. *Indoor Air*, 30, 315-325. DOI: [10.1111/ina.12633](https://doi.org/10.1111/ina.12633).
87. Alavy M, Li T, Siegel JA. 2020. Energy use in residential buildings: Analyses of high-efficiency filters and HVAC fans. *Energy & Buildings*, 209, Article 109697. DOI: [10.1016/j.enbuild.2019.109697](https://doi.org/10.1016/j.enbuild.2019.109697).
86. Alavy M, Siegel JA. 2020. In-situ effectiveness of residential HVAC filters. *Indoor Air*, 30, 156-166. DOI: [10.1111/ina.12617](https://doi.org/10.1111/ina.12617).
85. Young CJ, Zhou S., Siegel JA, Kahan T. 2019. Illuminating the dark side of indoor oxidants. *Environmental Science: Processes & Impacts*, 21, 1229-1239. DOI: 10.1039/c9em00111e.
85. Hems R, Wang C, Collins D, Zhou S, Borduas-Dedekind N, Siegel J, Abbatt J. 2019. Sources of isocyanic acid (HNCO) indoors: a focus on cigarette smoke. *Environmental Science: Processes & Impacts*, 21, 1334-1341. DOI: 10.1039/c9em00107g.
84. Li T, Alavy M, Siegel JA. 2019. Measurement of Residential HVAC Runtime. *Building and Environment*, 150, 99-107. DOI: <https://doi.org/10.1016/j.buildenv.2019.01.004>.
83. Vakalis D, Touchie, M, Tzekova, E, MacLean HL, Siegel JA. 2019. Indoor Environmental Quality Perceptions of Social Housing Residents. *Building and Environment*, 150, 135-143. DOI: <https://doi.org/10.1016/j.buildenv.2018.12.062>.
82. Alavy M, Siegel JA. 2019. IAQ and Energy Implications of High Efficiency Filters in Residential Buildings: A Review (RP-1649). *Science and Technology for the Built Environment*, 25, 261-271. DOI: <https://doi.org/10.1080/23744731.2018.1526012>.
81. Givehchi R, Maestre JP, Bi C, Wylie G, Xu Y, Kinney K, Siegel JA. 2019. Quantitative Filter Forensics with Residential HVAC Filters to Assess Indoor Concentrations. *Indoor Air*, 29, 390–402. DOI: <https://doi.org/10.1111/ina.12536>.
80. Collins D, Hems R, Zhou S, Alavy M, Siegel J, Abbatt J. 2018. Evidence for Gas-Surface Equilibrium Control of Indoor Nitrous Acid. *Environmental Science & Technology*, 52, 12419–12427. DOI: <https://pubs.acs.org/doi/abs/10.1021/acs.est.8b04512>.
79. Bi C, Maestre JP, Li H, Zhang G, Givehchi R, Mahdavi A, Kinney K, Siegel JA, Horner S, Xu Y. 2018. Phthalates and organophosphates in settled dust and HVAC filter dust of U.S. low-income

- homes: association with season, building characteristics, and childhood asthma. *Environment International*, **121**, 916-930. <https://doi.org/10.1080/23744731.2018.1526012>.
78. Alavy M, Li T, Siegel JA. 2018 Exploration of a long-term measurement approach for air exchange rate. *Building and Environment*, **144**, 474-481.
  77. Diaz Lozano Patiño E, Vakalis D, Touchie, M, Tzekova, E, Siegel JA. 2018. Thermal Comfort in Multi-Unit Social Housing Buildings. *Building and Environment*, **144**, 230-237.
  76. Touchie M, Siegel JA. 2018. Residential HVAC Runtime from Smart Thermostats: Characterization, Comparison, and Impacts. *Indoor Air*, **28**, 905-915. DOI: 10.1111/ina.12496.
  75. Bakker A, Siegel JA, Mendell MJ, Peccia J. 2018. Building and environmental factors that influence bacterial and fungal loading on air conditioning cooling coils. *Indoor Air*, **28**, 689-696.
  74. Diaz Lozano Patino E, Siegel JA. 2018. Indoor environmental quality in social housing: A literature review. *Building and Environment*, **131**, 231-241.
  73. Maestre JP, Jennings W, Wylie G, Horner S, Siegel JA, Kinney K. 2018. Filter Forensics: Microbiome Recovery from Residential HVAC Filters. *Microbiome*, **6**(22), 1-14
  72. Thompson et al., and The Earth Microbiome Project Consortium (Siegel, J., member). 2017. A communal catalogue reveals Earth's multiscale microbial diversity. *Nature* **551**:457-463.
  71. Lax et al. (21 authors). 2017. Bacterial colonization and succession in a newly opened hospital *Science Translational Medicine*, **9**(391),1-11, DOI: 10.1126/scitranslmed.aah6500.
  70. Haaland, D, Siegel, JA 2017. Quantitative Filter Forensics for Indoor Particle Sampling. *Indoor Air*, **27**(2), 364-376.
  69. Adams R, Bhangar B, Dannemiller K, Eisen J, Fierer N, Gilbert J, Green J, Marr L, Miller S, Siegel JA, Stephens B, Waring M, Bibby K. 2016. Ten questions concerning the microbiomes of buildings. *Building and Environment*, **109**, Pages 224-234.
  68. Chase J, Fouquier J, Zare M, Sonderegger D, Knight R, Kelley S, Siegel JA, Caporaso, JG. 2016. Geography and location are the primary drivers of office microbiome composition, *mSystems*, **1**(2) DOI: 10.1128/mSystems.00022-16.
  67. Zaatari, M, Novoselac, A, Siegel, JA 2016. Impact of ventilation and filtration strategies on energy consumption and exposures in retail stores. *Building and Environment*, **100**, 186-196.
  66. Siegel, JA 2016 Keynote: Primary and Secondary Consequences of Indoor Air Cleaners. *Indoor Air*, **26**, 88-96.
  65. Aldred J, Darling E, Morrison GC, Siegel JA, Corsi RL 2016. Analysis of the Cost Effectiveness of Combined Particle and Activated Carbon Filters for Indoor Ozone Removal in Buildings (ASHRAE RP-1491). *Science and Technology for the Built Environment (formerly HVAC&R Research)*, **22**(2), 227-236.
  64. Hoisington A, Maestre, J.P, Kinney K.A, Siegel JA 2016. Characterizing the Bacterial Communities in Retail Stores in the United States. *Indoor Air*, **26**(6), 857-868.
  63. Khurshid, S, Siegel, JA, Kinney K.A. 2016. Particulate Reactive Oxygen Species on Total Suspended Particles – Measurements in Residences in Austin, Texas. *Indoor Air*, **26**, 953-963.
  62. Aldred J, Darling E, Morrison GC, Siegel JA, Corsi RL. 2016. Benefit-cost analysis of commercially available activated carbon filters for indoor ozone removal in single-family homes. *Indoor Air*.
  61. Dedesko S, Siegel JA 2015. Moisture parameters and fungal communities associated with gypsum drywall in buildings. *Microbiome*, **3**:71. DOI 10.1186/s40168-015-0137-ys.
  60. Dedesko S, Stephens B, Gilbert JA, Siegel JA 2015. Methods to Assess Human Occupancy and Occupant Activity in Hospital Patient Rooms. *Building and Environment*, **90**, 136-145.
  59. Gall, E.T, Siegel, JA, Corsi, RL 2015. Modeling ozone removal to indoor materials, including the effects of porosity, pore diameter, and thickness. *Environmental Science and Technology*, **49**, 4398-4406.
  58. Ramos T, Dedesko S, Siegel JA, Gilbert JA, Stephens, B. 2015. Spatial and temporal variations in indoor environmental conditions, human occupancy, and operational characteristics in a new hospital environment. *PLoS ONE*. **10**(3): e0118207. doi:10.1371/journal.pone.0118207.

57. Xu Y, Liang, Y, Urquidi J, Siegel, JA 2015. Semi-volatile Organic Compounds in HVAC Filter Dust in Retail Stores. *Indoor Air*, **25**, 79-92.
56. Nirlo, E, Crain, N, Corsi, R.L, Siegel, JA 2015. Field evaluation of five VOC measurement techniques: Implications for green building decision making. *Science and Technology for the Built Environment (formerly HVAC&R Research)*, **21**, 67–79.
55. Khurshid, S. Siegel, JA, Kinney K.A. 2014. Technical Note: Particulate reactive oxygen species concentrations and their association with environmental conditions in an urban, subtropical climate. *Atmospheric Chemistry and Physics*, **14**, 6777-6784.
54. Hoisington, A, Maestre, J.P, Siegel, JA, Kinney, K.A. 2014. Impact of Sampler Selection on the Characterization of the Indoor Microbiome via High-Throughput Sequencing, *Building and Environment*, **80**, 274-282.
53. Khurshid, S. Siegel, JA, Kinney K.A. 2014. Indoor Particulate Reactive Oxygen Species Concentrations. *Environmental Research*, **132**, 46-53.
52. Gall, E.T, Corsi, R.L, Siegel, JA 2014. Impact of Physical Properties on Ozone Removal to Several Porous Materials. *Environmental Science and Technology*, **48(7)**, 3682–3690.
51. Xu Y, Liang, Y, Urquidi J, Siegel, JA 2014. Phthalates and Polybrominated Diphenyl Ethers in Retail Stores. *Atmospheric Environment*, **87**, 53–64.
50. Nirlo, E, Crain, N, Corsi, R.L, Siegel, JA 2014. Volatile organic compounds in fourteen U.S. retail stores. *Indoor Air*, **24**, 484–494.
49. Zaatari, M, Novoselac, A, Siegel, JA 2014. The Relationship between Filter Pressure Drop, Indoor Air Quality, and Energy Consumption in Rooftop HVAC Units. *Building and Environment*, **73**, 151-161.
48. Zaatari, M, Siegel, JA 2014. Particle Characterization in Retail Environments: Concentrations, Sources, and Removal Mechanisms. *Indoor Air*, **24**, 350-361.
47. Zaatari, M, Nirlo, E, Jareemit, D, Crain, N, Srebric, J, Siegel, JA 2014. Ventilation and Indoor Air Quality in Retail Stores: A Critical Review (RP 1596). *HVAC&R Research*, **20**, 276-294.
46. Hoisington, A, Maestre, J.P, Siegel, JA, Kinney, K.A. 2014. Exploring the Microbiome of the Built Environment: A Primer on Four Biological Methods Available to Building Professionals. *HVAC&R Research*, **20**, 1-9.
45. Taylor Lange, S, Juenger, M. GC, Siegel, JA 2014. Radon Emanation Fractions from Concretes Containing Fly Ash and Metakaolin. *Science of the Total Environment*, **46**, 1060-1065.
44. Shogan, B, Smith, D, Packman, A, Kelley, S, Landon, E, Bhangar, S, Vora, G, Jones, R, Keegan, K, Stephens, B, Ramos, T, Kirkup, B, Levin, H, Rosenthal, M, Foxman, B, Chang, E, Siegel, J, Cobey, S, An, G, Alverdy, J, Olsiewski, P, Martin, M, Marrs, R, Hernandez, M, Christley, S, Morowitz, M, & Weber, S. 2013. The Hospital Microbiome Project: Meeting Report for the 2nd Hospital Microbiome Project, Chicago, USA, January 15th, 2013. *Standards In Genomic Sciences*, 8(3). doi:10.4056/sigs.4187859
43. Gall, E, Darling E, Siegel, JA, Morrison GC, Corsi, RL 2013. Evaluation of several green building materials for ozone removal, primary and secondary emissions. *Atmospheric Environment*. **77**, 910-918.
42. Waring, M. Siegel, JA 2013. Secondary Organic Aerosol Formation from Reactions between Ozone and Surface-Sorbed d-Limonene. *Environmental Science and Technology*, **47(12)**, 6341–6348
41. Stephens, B.R, Siegel JA 2013. Ultrafine particle removal by residential HVAC filters. *Indoor Air*, **23**, 488–497.
40. Boor, B, Siegel, JA, Novoselac, A. 2013. Wind Tunnel Study on Aerodynamic Particle Resuspension from Monolayer and Multilayer Deposits on Indoor Surfaces. *Aerosol Science and Technology*, **47(8)**, 848-857.
39. Boor, B, Siegel, JA, Novoselac, A. 2013. Monolayer and Multilayer Particle Deposits on Hard Surfaces: Literature Review and Implications for Particle Resuspension in the Indoor Environment. *Aerosol Science and Technology*, **47(8)**, 831-847.

38. Taylor Lange, S, Juenger, M. GC, Siegel, JA 2013. Engineering Cement Renders to Improve Air Quality. *Atmospheric Environment*, **70**, 263-266.
37. Smith, D, Alverdy, J, Gilbert, J, Coleman, M, Garcia-Houchins, S, Green, J, Keegan, K, Kelley, S, Kirkup, B, Kociolek, L, Levin, H, Landon, E, Olsiewski, P, Knight, R, Siegel, J, Weber, S, Gilbert, JA, 2013. The Hospital Microbiome Project: Meeting Report for the 1st Hospital Microbiome Project Workshop on sampling design and building science measurements, Chicago, USA, June 7th-8th 2012. *Standards in Genomic Sciences*. **8(1)**, doi:10.4056/sigs.3717348.
36. Stephens, B.R, Siegel JA 2012. Penetration of ambient submicron particles into single-family residences: associations with building characteristics. *Indoor Air*, **22(4)**, 501–513.
35. Taylor Lange, S, Stewart, J, Juenger, M. GC, Siegel, JA 2012. The contribution of fly ash toward indoor radon pollution from concrete. *Building and Environment*, **56**, 276-282.
34. Cros, C, Morrison, GC, Siegel, JA, Corsi, RL 2012. Long-term performance of passive materials for removal of ozone from indoor air. *Indoor Air*, **22(1)**, 45-53.
33. Stephens, B.R, Gall, E.T, Siegel JA 2012. Measuring the penetration of ambient ozone into residential buildings. *Environmental Science and Technology*, **46(2)**, 929–936.
32. Stephens, B.R, Siegel JA 2012. Comparison of Test Methods for Determining Particle Removal Efficiency of Filters in Residential and Light-commercial Central HVAC Systems. *Aerosol Science and Technology*, **46(5)**, 504-513.
31. Stephens, B, Novoselac, A, Siegel JA 2011. Operation characteristics of residential and light-commercial air-conditioning systems in a hot and humid climate zone. *Building and Environment*, **46(10)**, 1972-1983.
30. Hun D.E, Corsi R. L, Morandi M.T, Siegel JA 2011. Automobile proximity and Indoor Residential Concentrations of BTEX and MTBE. *Building and Environment*, **46**, 45-53.
29. Waring, M.S, Wells, J.R, Siegel, JA 2011. Secondary Organic Aerosol Formation from Ozone Reactions with Single Terpenoids and Terpenoid Mixtures. *Atmospheric Environment*, **45(25)**, 4235-4242
28. Waring, M.S, Siegel, JA 2011. Indoor air quality implications of using ion generators in residences. *Indoor Air*, **21(3)**, 267-276.
27. Gall, E.T, Corsi, R, Siegel, JA 2011. Barriers and Opportunities for Passive Removal of Indoor Ozone. *Atmospheric Environment*, **45(19)**, 3338-3341.
26. Noris, F, Siegel, JA, Kinney, K.A. 2011. Evaluation of HVAC filters as a sampling mechanism for indoor microbial communities. *Atmospheric Environment*, **45**, 338-346.
25. Peschiera, G, Taylor, J.T, Siegel JA 2010. Response-Relapse Patterns of Building Occupant Electricity Consumption Following Exposure to Personal, Contextualized and Occupant Peer Network Utilization Data. *Energy and Buildings*, **42**, 1329–1336.
24. Waring, M.S, Siegel, JA 2010. The Influence of HVAC Systems on Indoor Secondary Organic Aerosol Formation. *ASHRAE Transactions*, **116(1)**, 556-571.
23. Hun D.E, Corsi R. L, Morandi M.T, Siegel JA 2010. Formaldehyde in Residences: Long-Term Indoor Concentrations and Influencing Factors. *Indoor Air*, **20(3)**, 196-203
22. Stephens, B, Novoselac, A, Siegel JA 2010. Energy Implications of Filters in Residential and Light-Commercial Buildings. *ASHRAE Transactions*, **116(1)**, 346-357.
21. Stephens, B, Novoselac, A, Siegel JA 2010. The Effects of Filtration on Pressure Drop and Energy Consumption in Residential HVAC Systems. *HVAC&R Research*, **16(3)**, 273-294.
20. Kunkel, D.A, Gall, E.T, Siegel, JA, Novoselac, A, Morrison, GC, Corsi, RL 2010. Passive Reduction of Human Exposure to Indoor Ozone. *Building and Environment*, **45(2)**, 445–452.
19. Hun D.E, Siegel JA, Morandi M.T, Stock, T.H, Corsi R. L. 2009. Cancer risk disparities between Hispanic and non-Hispanic White populations: The role of exposure to indoor air pollution. *Environmental Health Perspectives*, **117 (12)**, 1925-1931.
18. Noris, F, Siegel, JA, Kinney, K.A. 2009. Biological and Chemical Contaminants in HVAC Filter Dust. *ASHRAE Transactions*, **115(2)**, 484-491.



17. Mukai, C, Siegel, JA, Novoselac, A. 2009. Impact of Airflow Characteristics on Particle Resuspension from Indoor Surfaces. *Aerosol Science and Technology*, **43(10)**, 1022-1032
  16. Novoselac, A, Siegel, JA 2009. Effective Positioning of Portable Air Cleaning Devices in Multizone Residential Buildings. *Building and Environment*, **44(12)**, 2348-2356.
  15. Chojnowski, D.B. Nigro, P.J. Siegel, JA, Kosar. D.A. 2009 Laboratory Measurements to Quantify the Effect of Bypass on Filtration Efficiency. *ASHRAE Transactions*, **115(1)**, 191-198.
  14. VerShaw, J.R, Siegel, JA, Chojnowski, D.B, Nigro, P.J. 2009. Implications of Filter Bypass. *ASHRAE Transactions*, **115(1)**, 199-207.
  13. Rim, D, Siegel, JA, Spinhirine, J, Webb, A, McDonald-Buller, E. 2008. Characteristics of Cabin Air Quality in School Buses in Central Texas. *Atmospheric Environment* , **42**, 6453-6464.
  12. Waring, M, Siegel, JA, Corsi, R. 2008. Ultrafine particle removal and generation by portable air cleaners. *Atmospheric Environment*, **42**, 5003-5014.
  11. Waring, M, Siegel, J. A. 2008. Particle loading rates for HVAC filters, heat exchangers, and ducts. *Indoor Air*, **18**, 209-224.
  10. Corsi, R. L, Siegel, J. A, Chiang C. 2008. Particle resuspension during the use of vacuum cleaners on residential carpet. *Journal of Occupational and Environmental Hygiene*, **5**, 232-238.
  9. Waring, M, Siegel, JA 2007. An evaluation of the indoor air quality in bars before and after a smoking ban in Austin, TX. *Journal of Exposure Analysis and Environmental Epidemiology*, **17**, 260-268.
  8. Zhao, P, Siegel J, Corsi, R. 2007. Ozone removal by HVAC filters. *Atmospheric Environment*, **41**, 3151-3160.
  7. Corsi, R, Siegel J, Karamalegos, A, Simon, H, Morrison, G. 2007. Personal Reactive Clouds: Introducing the concept of near head chemistry. *Atmospheric Environment* , **41**, 3161-3165.
  6. Francisco, P. Siegel, J, Palmiter, L. Davis, B. 2006. Measuring Residential Duct Efficiency with the Short-Term Coheat Test Methodology. *Energy and Buildings*, **38**, 1076-1083.
  5. Ward, M, Siegel, JA, Corsi, R. L. 2005. The effectiveness of stand alone air cleaners for shelter-in-place. *Indoor Air*, **15**, 127-134.
  4. Ward, M, Siegel, JA, 2005. Filter Bypass: Implications for Filter Efficiency. *ASHRAE Transactions*. **111(2)**, 1091-1100.
  3. Siegel, JA, Nazaroff, W.W. 2003. Predicting particle deposition on HVAC heat exchangers. *Atmospheric Environment*, **37**, 5587-5596.
  2. Siegel, J, McWilliams, J, Walker, I. 2003. Comparison Between Predicted Duct Effectiveness from Proposed ASHRAE Standard 152P and Measured Field Data for Residential Forced Air Cooling Systems. *ASHRAE Transactions*, **109(1)**, 503-512.
  1. Siegel, JA, Wray, C. P. 2002. An Evaluation of Refrigerant Charge Diagnostics for Commissioning Residential Cooling Systems. *ASHRAE Transactions*, **108(2)**, 965-975.
- Five additional manuscripts in review as of Aug. 31, 2020.

**PEER-REVIEWED CONFERENCE PROCEEDINGS, CONTRIBUTED ESSAYS, REPORTS, OTHER**

- Collins D, Hems R, Zhou S, Wang C, Alavy M, Siegel J, Abbatt J. (2018). Insights on the Multiphase Chemistry of Indoor Trace Gases and Aerosols. *Indoor Air 2018: Proceedings of the 15th International Conference on Indoor Air and Climate*, Paper 208.
- Bi C, Maestre J, Kinney K, Siegel, JA, Horner S, Xu Y. (2018) Semi-volatile Organic Compounds in Indoor Settled and HVAC filter dust: Association with Seasons, Childhood Asthma and Building characteristics. *Indoor Air 2018: Proceedings of the 15th International Conference on Indoor Air and Climate*, Paper 499.
- Givehchi R, Maestre J, Kinney K, Wylie D, Horner S, Siegel JA. (2018) Quantitative Filter Forensics to Determine the Airborne Concentration of Endotoxins and Allergens in Residential HVAC Filters. *Indoor Air 2018: Proceedings of the 15th International Conference on Indoor Air and Climate*, Paper 587.

- Wan Y, Diamond M, Siegel J. (2018) Exposure to Phthalate Esters (PAEs) in Social Housing Apartments. *Indoor Air 2018: Proceedings of the 15th International Conference on Indoor Air and Climate*, Paper 621.
- Li T, Siegel JA. (2018) Impacts of HVAC Sequencing on Runtime. *Indoor Air 2018: Proceedings of the 15th International Conference on Indoor Air and Climate*, Paper 645.
- Lepine C, Brook J, Takaro T, Subbarao P, Turvey S, Mandhane M, Becker A, Lefebvre D, Sears M, Scott J, Siegel, JA. (2018) What do Participants in a Birth Cohort Study Know About Their Homes? *Indoor Air 2018: Proceedings of the 15th International Conference on Indoor Air and Climate*, Paper 653.
- Lepine C, Fan P, Scott J, Caporaso GC, Siegel, JA. (2018) When Does Wet Drywall Not Grow Mold? *Indoor Air 2018: Proceedings of the 15th International Conference on Indoor Air and Climate*, Paper 656.
- Diaz Lozano Patiño E, Siegel JA. (2018) A Review of Contaminant Concentrations in Social Housing. *Indoor Air 2018: Proceedings of the 15th International Conference on Indoor Air and Climate*, Paper 660.
- Bakker, A, Siegel, JA, Mendell, MJ, Peccia, J. (2018) Building Factors that Influence Bacterial and Fungal Concentrations on Air Conditioner Cooling Coils. *Indoor Air 2018: Proceedings of the 15th International Conference on Indoor Air and Climate*, Paper 698.
- Alavy M, Li T, Siegel, JA. (2018) Long-term Air Exchange Rates in a Residence. *Indoor Air 2018: Proceedings of the 15th International Conference on Indoor Air and Climate*, Paper 751.
- Siegel JA. (2018) Efficiency Declines in Residential Electret Filters. *Indoor Air 2018: Proceedings of the 15th International Conference on Indoor Air and Climate*, Paper 754.
- Vakalis D, MacLean H, Siegel JA . (2018) Prevalence of building features with possible impacts on student outcomes in LEED-certified schools. *Indoor Air 2018: Proceedings of the 15th International Conference on Indoor Air and Climate*, Paper 770.
- Fan P, Lepine C, Siegel, JA. (2018) Gypsum Response to Liquid Water Wetting in Indoor Environments. *Indoor Air 2018: Proceedings of the 15th International Conference on Indoor Air and Climate*, Paper 772.
- Siegel JA. (2018) What are the limitations of filtration in the existing North American housing stock? *Indoor Air 2018: Proceedings of the 15th International Conference on Indoor Air and Climate*, Paper 773.
- Mahdavi A, Siegel JA . (2018) Extraction of Dust Collected in HVAC Filters. *Indoor Air 2018: Proceedings of the 15th International Conference on Indoor Air and Climate*, Paper 800.
- Diaz Lozano Patiño E, Mahdavi A, Siegel, JA. (2018) Particulate Matter Emission Rates from Common Scent Sources. *ASHRAE Conference Paper HO-18-C011*, 1-10.
- Alavy M, Li T, Mahdavi A, Siegel, JA. (2018) In-situ Integrated Filter Efficiency Measurement. *ASHRAE Conference Paper HO-18-C012*.
- Collins D, Hems R, Zhou S, Siegel J, Abbatt J. (2017). Online Chemical and Size Distribution Analysis of Carbonaceous Aerosol Associated with Combustion in a Residence. *Proceedings of Healthy Buildings Europe 2017*.
- Siegel J. (2017). Indoor Chemistry and Building Science: An opportunity for symbiosis. *Proceedings of Healthy Buildings Europe 2017*.
- Siegel, J. 2017. IEQ Applications: IAQ Implications Of Cannabis Legalization. *ASHRAE Journal*, February 2017, 62-64.
- Touchie M, Tzekova E, Siegel J, Purcell B, Morier J. 2016. Evaluating Summertime Overheating in Multi- Unit Residential Buildings using Surveys and In-Suite Monitoring. *Thermal Performance of the Exterior Envelopes of Whole Buildings XIII Conf*.
- Khamsehi B., Siegel J. 2016. A Meta-Analysis on Indoor Bacteria and Chronic Health Outcomes. *Indoor Air 2016: Proceedings of the 14th International Conference on Indoor Air and Climate*, Paper 1039.

- Alavy M, Siegel J. 2016. In-situ integrated HVAC filter efficiency. *Indoor Air 2016: Proceedings of the 14th International Conference on Indoor Air and Climate*, Paper 1033.
- Bi C. \*, Maestre J, Kinney K, Siegel J, Horner S, Xu Y. 2016. Semi-volatile organic compounds in indoor settled and HVAC filter dust: seasonal variance and association with building characteristics. *Indoor Air 2016: Proceedings of the 14th International Conference on Indoor Air and Climate*, Paper 345.
- Mahdavi\*, D. Haaland, J. Siegel. 2016. Particulate Matter Concentrations in Multi-Unit Social Housing. *Indoor Air 2016: Proceedings of the 14th International Conference on Indoor Air and Climate*, Paper 1011.
- Maestre J, Jennings W, Wylie D, Dedesko, S, Horner, S, Siegel J, Kinney K. 2016. Home Microbiome and Childhood Asthma in Low Income Rural Homes. *Indoor Air 2016: Proceedings of the 14th International Conference on Indoor Air and Climate*, Paper 999.
- Kinney K. \*, Hoisington, A. Maestre J, Siegel J, King M. 2016. Lessons Learned: Microbiome Assessments in Non-Residential Environments. *Indoor Air 2016: Proceedings of the 14th International Conference on Indoor Air and Climate*, Paper 1111.
- Siegel J. 2016. Prebiotic Buildings: A note of caution. *Indoor Air 2016: Proceedings of the 14th International Conference on Indoor Air and Climate*, Paper 968.
- Scott J, Lepine C. \*, Sears M. R, Lefebvre D, Dai, D. Siegel J, Erdman L, Subbarao P, Turvey S, Brook J. R, Takaro T. K. 2016. The Canadian Healthy Infant Longitudinal Development (CHILD) Study: Indoor markers of moisture in a prospective birth cohort. *Indoor Air 2016: Proceedings of the 14th International Conference on Indoor Air and Climate*, Paper 1015.
- Haaland, D, Tzekova, E, Purcell, B, Siegel, J. 2016. Pre-Retrofit Assessment of Thermal Comfort and Excess Moisture in Post-War Multi-Unit Residential Buildings in Toronto. *ASHRAE Conference Paper ST-16-C029*.
- Touchie, M, Siegel J, 2015. Operation Of Residential HVAC Systems: Implications For Healthy Buildings. *Proceedings of Healthy Buildings America 2015*, 5-9.
- Haaland, D, Siegel J, 2015. Challenges And Opportunities For Filter Forensics. *Proceedings of Healthy Buildings America 2015*, 86-90.
- Dedesko, S, Siegel, J. 2015. Moisture Measurement And Implications For Fungal Growth In Drywall. *Proceedings of Healthy Buildings America 2015*, 202-205.
- Siegel, J. Moisture and the Indoor Microbiome, *Proceedings of Healthy Buildings Europe 2015*, paper ID 561.
- Dedesko, S, Ramos, T, Gilbert JA, Stephens, B, Siegel, JA 2014. Using carbon dioxide and doorway beam-break sensors to determine occupancy in hospital patient rooms. *Indoor Air 2014: Proceedings of the 13th International Conference on Indoor Air and Climate*, Paper 156.
- Gall, E.T, Siegel, JA, Corsi, RL 2014. Sensitivity analysis of ozone-material modeling for porous materials in indoor environments. *Indoor Air 2014: Proceedings of the 13th International Conference on Indoor Air and Climate*, Paper 201.
- Gilbert, J, Handley, K, Starkey, K, Hampton Marcel, J, Siegel, JA, Kirkup, B, Stephens, B. 2014. The Hospital Microbiome Project, *Indoor Air 2014: Proceedings of the 13th International Conference on Indoor Air and Climate*, Paper 207.
- Khurshid, S, Kinney K.A, Siegel, JA 2014. The role of ozone and terpenes on the concentration of indoor particulate reactive oxygen species. *Indoor Air 2014: Proceedings of the 13th International Conference on Indoor Air and Climate*, Paper 352.
- Ramos, T, Azimi, P, Dide, L, Dedesko, S, Gilbert JA, Siegel, JA, Stephens, B. 2014. Building science measurements in the Hospital Microbiome Project. *Indoor Air 2014: Proceedings of the 13th International Conference on Indoor Air and Climate*, Paper 685.
- Siegel, JA, Novoselac, A, Morrison, GC. 2014. A laboratory method for measuring ozone emission from in-duct air cleaners. *Indoor Air 2014: Proceedings of the 13th International Conference on Indoor Air and Climate*, Paper 738.

- Xu Y, Liang, Y, Urquidi J, Siegel, JA 2014. Phthalates and Polybrominated Diphenyl Ethers in Retail Stores. *Indoor Air 2014: Proceedings of the 13th International Conference on Indoor Air and Climate*, Paper 896.
- Zare, M, Siegel, JA, 2014. Equilibrium relative humidity measurements on common office surfaces. *Indoor Air 2014: Proceedings of the 13th International Conference on Indoor Air and Climate*, Paper 942.
- Siegel, JA, Zare, M, Chase, J, Fouquier, J, Kelley, S, Caporaso, J.G, 2014. Impact of building science parameters on microbial communities on indoor surfaces. *Indoor Air 2014: Proceedings of the 13th International Conference on Indoor Air and Climate*, Paper 943.
- Zaatari, M, Novoselac, A, Siegel JA 2013. The Relationship between Filter Pressure Drop, Indoor Air Quality, and Energy Consumption in Rooftop HVAC Units. *Proceedings of ASHRAE IAQ 2013*.
- Nirlo, E, Crain, N, Corsi, R, Siegel, JA 2013. Formaldehyde Concentration and Control in Retail Buildings. *Proceedings of ASHRAE IAQ 2013*.
- Xu Y, Liang, Y, Urquidi J, Siegel, JA 2013. Phthalates and Polybrominated Diphenyl Ethers in Retail Stores. *Proceedings of ASHRAE IAQ 2013*.
- Morrison, GC, Shaughnessy, R.L, Siegel, JA 2013. In-duct air cleaning devices: Ozone emission rates and test methodology. Final Report submitted to The California Air Resources Board for Contract No. 09-34.
- Siegel, JA et al. (12 Authors). 2013. RP1596: Ventilation and Indoor Air Quality in Retail Stores Final report submitted to ASHRAE.
- Hoisington A, Maestre, J, Bae, S, Siegel, JA, Kinney, K. 2012. "What is in the air in retail stores? A DNA-based study of bacterial and fungal communities in retail environments." *Proceedings of Healthy Buildings 2012*.
- Khurshid S, Siegel, JA, Kinney, K. 2012. "The Relative Concentrations of Reactive Oxygen Species in Indoor and Outdoor Air." *Proceedings of Healthy Buildings 2012*.
- Urquidi, J, Liang, Y, Siegel, JA, Xu, Y. 2012. "Phthalates and Polybrominated Diphenyl Ethers in Retail Stores." *Proceedings of Healthy Buildings 2012*.
- Khurshid S, Siegel, J, Kinney, K. 2012. "The Relative Concentrations of Reactive Oxygen Species in Indoor and Outdoor Air." *Proceedings of the Air and Waste Management Association 2012 Annual Meeting*.
- Gall, E.T, Corsi, R, Siegel, JA 2012. "Modeling Indoor Environments with Experimentally Determined Molar Yields." *Proceedings of the Air and Waste Management Association 2012 Annual Meeting*.
- Siegel, J. 2011. Engineering the Indoor Environment in Weinthal, L. (ed.) "Toward a New Interior: An Anthology of Interior Design Theory." New York: Princeton Architectural Press
- Cros, C, Morrison, GC, Siegel, JA, Corsi, RL 2011. Passive Removal Of Indoor Ozone By Green Building Materials. *Indoor Air 2011: Proceedings of the 12th International Conference on Indoor Air and Climate*, paper ID 103.
- Stephens, B.R, Gall, E.T, Siegel, JA 2011. A Method For Measuring Ozone Penetration Through The Building Envelope. *Indoor Air 2011: Proceedings of the 12th International Conference on Indoor Air and Climate*, paper ID 148.
- Gall, E.T, Corsi, R, Siegel, JA 2011. Determination Of Ozone Reaction Probabilities With Porous Materials. *Indoor Air 2011: Proceedings of the 12th International Conference on Indoor Air and Climate*, paper ID 175.
- Hun D.E, Corsi R. L, Morandi M.T, Siegel JA 2011. Automobile Proximity And Indoor Residential Concentrations Of BTEX And MTBE. *Indoor Air 2011: Proceedings of the 12th International Conference on Indoor Air and Climate*, paper ID 592.
- Taylor Lange , S. C, Cros, C, Juenger, M. C. G, Siegel, JA, Poppendieck, D. 2011. The Role of Material Porosity on Ozone Uptake of Metakaolin-concrete Surfaces. *Indoor Air 2011: Proceedings of the 12th International Conference on Indoor Air and Climate*, paper ID 933.

- Stephens, B.R, Siegel, JA 2011. Comparison Of HVAC Filter Test Methods For Particle Removal Efficiency. *Indoor Air 2011: Proceedings of the 12th International Conference on Indoor Air and Climate*, paper ID 945.
- Waring, M.S, Siegel, JA 2011. Yields of Secondary Organic Aerosol from Reactions between Ozone and Surface-Adsorbed d-Limonene. *Indoor Air 2011: Proceedings of the 12th International Conference on Indoor Air and Climate*, paper ID 958.
- Siegel, JA 2011. Energy Implications of Residential Particle Control Technologies. *Indoor Air 2011: Proceedings of the 12th International Conference on Indoor Air and Climate*, paper ID 1003.
- Rhodes, J.D, Nirlo, E. Srebric, J, Siegel, JA 2011. Indoor Air Quality In Retail Buildings: A Review. *Indoor Air 2011: Proceedings of the 12th International Conference on Indoor Air and Climate*, paper ID 1008.
- Taylor Lange , S, Juenger, M. C. G, Siegel, JA Indoor Radon Exhalation Rates From Concrete With Fly Ash. *Indoor Air 2011: Proceedings of the 12th International Conference on Indoor Air and Climate*, paper ID 1015.
- Gunther, M, Rhodes, J.D, Morrison, GC, Siegel, JA A Laboratory Method For Measuring The Ozone Emission From In-duct Air Cleaners. *Indoor Air 2011: Proceedings of the 12th International Conference on Indoor Air and Climate*, paper ID 1069.
- Gall, E.T, Siegel, JA, Corsi, RL 2011. Zero-Energy Removal of Ozone in Residences. *ASHRAE Transactions*, **117**(1), LV-11-C050, 411-418.
- Boor, B.E, Siegel, JA, Novoselac, A. 2011. Development of an Experimental Methodology to Determine Monolayer and Multilayer Particle Resuspension from Indoor Surfaces. *ASHRAE Transactions*, **117**(1), LV-11-C053, 434-441.
- Jackson, M, Aldred, J, Canady, J, Corsi, R.L, Siegel, JA 2010. The potential role of toilets as a vector for transmission of infectious disease. *IAQVEC 2010: Proceedings of the 7th International Conference on Indoor Air Quality, Ventilation, and Energy Conservation*, paper ID 87-112, 1-8.
- Rosenthal, J. and Siegel, JA 2009. Letter to the Editor: Does filter media type really affect BRS? *Indoor Air*, **19**(4), 346-347.
- Stephens, B, Novoselac, A, Siegel JA 2009. Energy Implications of Filters in Residential and Light-Commercial Buildings (RP-1299). American Society of Heating, Refrigeration and Air Conditioning Engineers, Atlanta, GA, 387 pp.
- Cros, C, Gall, E.T, Siegel, JA, Morrison, GC, and Corsi, RL 2009. Removal of Indoor Ozone with Reactive Materials: Preliminary Results and Implications. *Proceedings of Healthy Buildings 2009*, Paper ID 141, 1-4.
- Gall, E. T, Cros, C, Corsi, RL and Siegel, JA 2009. Time-scale analysis for reactive deposition of ozone via passive reactive materials (PRMs), *Proceedings of Healthy Buildings 2009*, Paper ID 336, 1-4.
- Hun D.E, Siegel JA, Morandi M.T, and Corsi R. L. 2009. Effect of ventilation rates on indoor formaldehyde concentrations in residences. *Proceedings of Healthy Buildings 2009*, Paper ID 695, 1-4.
- Noris, F, Kinney, K.A. and Siegel. JA 2009. HVAC filters as “passive” samplers: Fate analysis of indoor particles. *Proceedings of Healthy Buildings 2009*, Paper ID 535, 1-4.
- Siegel J, 2009. Do forced air HVAC systems have a role in healthy homes? *Proceedings of Healthy Buildings 2009*, Paper ID 680, 1-4
- Stephens, B, Novoselac, A, and Siegel JA 2009. Impacts of HVAC Filtration on Air-Conditioner Energy Consumption in Residences. *Proceedings of Healthy Buildings 2009*, Paper ID 474, 1-4.
- Waring M.S. and Siegel JA 2009. The influence of HVAC systems on secondary organic aerosol formation. *Proceedings of Healthy Buildings 2009*, Paper ID 727, 1-4.
- Kunkel, D.A, Corsi, R.L, Morrison, GC, Novoselac A, and Siegel, J. (2008). “Passive Ozone Control Through Use of Reactive Indoor Wall and Ceiling Materials.” *Proceedings of the Air and Waste Management*.

- Waring, M.S. and Siegel, JA (2008). “Indoor Air Quality Implications of Using Ion Generators in Residences.” *Indoor Air 2008: Proceedings of the 11<sup>th</sup> International Conference on Indoor Air and Climate*, paper ID 598, Copenhagen, Denmark, August 17-22, 2008, 1-8.
- Waring, M.S, Siegel, JA, Corsi, R.L, and Morrison, G. (2008). “Do surface reactions influence formation of secondary organic aerosol?” *Indoor Air 2008: Proceedings of the 11th International Conference on Indoor Air and Climate*, paper ID 603, Copenhagen, Denmark, August 17-22, 2008, 1.
- Siegel, JA, Chojnowski, D.B, Nigro, P.J, and Kosar, D. (2008). “HVAC Filter Bypass Modelling and Experimental Validation.” *Indoor Air 2008: Proceedings of the 11th International Conference on Indoor Air and Climate*, paper ID 343, Copenhagen, Denmark, August 17-22, 2008, 1-7.
- Shelton, G, Zhao, P, Corsi, R.L, and Siegel, JA (2008). “Ozone removal on HVAC filters: Underlying mechanisms, model development, and parameter estimation.” *Indoor Air 2008: Proceedings of the 11th International Conference on Indoor Air and Climate*, paper ID 271, Copenhagen, Denmark, August 17-22, 2008, 1-8.
- Noris, F, Kinney, K.A, and Siegel, JA (2008). “Comparison of Dust from HVAC Filters, Indoor Surfaces, and Indoor Air.” *Indoor Air 2008: Proceedings of the 11th International Conference on Indoor Air and Climate*, paper ID 553, Copenhagen, Denmark, August 17-22, 2008, 1-8.
- Kang, Y.K, Novoselac, A, and Siegel, JA (2008). “Effective Positioning of Portable Air Cleaning Devices in Multizone Residential Buildings.” *Indoor Air 2008: Proceedings of the 11th International Conference on Indoor Air and Climate*, paper ID 644, Copenhagen, Denmark, August 17-22, 2008, 1-8.
- Lohaus, J.H, Novoselac, A, and Siegel, JA (2008). “Particle Resuspension from Indoor Flooring Materials.” *Indoor Air 2008: Proceedings of the 11th International Conference on Indoor Air and Climate*, paper ID 342, Copenhagen, Denmark, August 17-22, 2008, 1.
- Hun, D.E, Morandi, M.T, Corsi, R.L, Siegel, JA, and Stock, T.H. (2008). “Exposure and Risk Disparities Between Mexican-American and White Populations in Houston.” *Indoor Air 2008: Proceedings of the 11th International Conference on Indoor Air and Climate*, paper ID 935, Copenhagen, Denmark, August 17-22, 2008, 1-8.
- Siegel J, Waring M, Yu X, and Corsi R, 2007. “Do Ion Generators Have A Role In Sustainable Indoor Environments?” *ASHRAE IAQ 2007*.
- Siegel, JA, Waring, M.S, Yu, X, and Corsi, R.L, 2006. "Indoor air quality implications of portable ion generators." *Proceedings of the A&WMA Specialty Conference on Indoor Environmental Quality – Problems, Research, and Solutions*, Research Triangle Park, North Carolina (July 2006) 1:1-12.
- Siegel JA, Novoselec, A, and Corsi, R.L, 2006. “Indoor Environmental Science and Engineering: An Integrated Academic Program.” *Proceedings of the Air and Waste Management Association/Environmental Protection Agency Indoor Air Quality Solutions Conference*, Research Triangle Park, North Carolina (July 2006) 8:1-7.
- Waring, M.S, Siegel, JA, and Huang, P, 2006. “An Evaluation of a Smoking Ban Ordinance in Bars in Austin, TX” *Proceedings of Healthy Buildings 2006*, Lisbon, Portugal, I, 137-142.
- Siegel, JA, Juenger, M, and Stewart, J, 2006. “Does the Addition of Fly Ash to Concrete Present a Radon Hazard?” *Proceedings of Healthy Buildings 2006*, Lisbon, Portugal, II, 501-506.
- Karamalegos, A, Simon, H, Zhao, P, Morrison, G, Siegel, J, and Corsi, R.L, 2005. “Personal Reactive Clouds: Introducing the concept of near head chemistry” *Indoor Air 2005: Proceedings of the 10th International Conference on Indoor Air and Climate*, II (2005), 2356-2360.
- Fradella, J. and Siegel, J, 2005. “An evaluation of shelter-in-place strategies in four industrial buildings” *Indoor Air 2005: Proceedings of the 10th International Conference on Indoor Air and Climate*, IV, (2005), 3360-3364.
- Zhao, P, Siegel, J. A, and Corsi, R. L, 2005. “Ozone removal by residential HVAC filters” *Indoor Air 2005: Proceedings of the 10th International Conference on Indoor Air and Climate*, II (2005), 2366-2370.

- Mullen, N, Yu, X, Zhao, P, Corsi, R. L, and Siegel, J. A, 2005. "Experimental Characterization of Portable Ion Generators" *Indoor Air 2005: Proceedings of the 10th International Conference on Indoor Air and Climate, IV* (2005), 2957-2961.
- Zhao, P, Siegel, J. A, and Corsi, R. L, 2005, "Ozone Removal by Residential HVAC Filters: For better or worse" *Proceedings of the Air and Waste Management Association 2005 Annual Meeting*.
- Siegel, J, Schmidt, K, and Cone, J, 2004. "INTICE - Interactive Technology to Improve the Classroom Experience." *Proceedings of the 2004 American Society for Engineering Education Annual Conference & Exposition* (2004), 2531-2542.
- Siegel, J. and Walker, I, 2003. "Integrating Ducts into the Conditioned Space: Successes and Challenges." *Building Integration Solutions: Proceedings of the Architectural Engineering 2003 Conference*, 1-9.
- Ward, M, Siegel J, and Corsi, R, 2003, "Stand Alone Air Cleaners: Evaluation and Implications." *Proceedings of the Air and Waste Management Association/Environmental Protection Agency Indoor Air Quality Solutions Conference*, Research Triangle Park, North Carolina (July 2003) 1:1-9.
- Siegel, J, Walker, I, and Sherman, M, 2002. "Dirty Air Conditioners: Energy Implications of Coil Fouling." *Proceedings of the 2002 ACEEE Summer Study on Energy Efficiency in Buildings*, 1 (2002), 287-300.
- Siegel, J. and Nazaroff W.W, 2002, "Modeling Particle Deposition on HVAC Heat Exchangers" in *Indoor Air 2002: Proceedings of the 9th International Conference on Indoor Air and Climate, I* (2002), 521-526.
- Siegel, J. and Walker, I, 2001, "Deposition of Biological Aerosols on HVAC Heat Exchangers" *ASHRAE IAQ 2001: Moisture, Microbes, and Health Effects: Indoor Air Quality and Moisture in Buildings*, 1-9.
- Siegel, J. and Carey, V.P, 2001, "Fouling of HVAC Fin and Tube Heat Exchangers" in *Heat Exchanger Fouling: Fundamental Approaches & Technical Solutions*, 4th International conference of fouling, 425-433.
- Siegel, J, Walker, I, and Sherman, M, 2000, "Delivering Tons to the Register: Energy Efficient Design and Operation of Residential Cooling Systems" in *Proceedings from the 2000 ACEEE Summer Study on Energy Efficiency in Buildings*, 1 (2000), 295-306.
- Siegel, J, Davis, R, Francisco, P, and Palmiter, L, 1998, "Measured Heating System Efficiency Retrofits in Eight Manufactured (HUD Code) Homes" in *Proceedings from the 1998 ACEEE Summer Study on Energy Efficiency in Buildings*, 2(1998), 189-201.
- Walker, I, Siegel, J, Brown, K, and Sherman, M, 1998, "Saving Tons at the Register" in *Proceedings from the 1998 ACEEE Summer Study on Energy Efficiency in Buildings*, 1(1998), 367-385.

## **SCHOLARLY PRESENTATIONS**

Over 25 scholarly presentations per year by applicant and graduate students including keynote/plenary presentations, invited presentations at the Institute of Medicine/National Academies and at universities, presentations at national and international technical (e.g., ASHRAE, Indoor Air, AAAR) conferences, and national/international symposia or workshops.

**TAB 1**





**STANDARD**

**ANSI/ASHRAE Standard 62.1-2019**  
(Supersedes ANSI/ASHRAE Standard 62.1-2016)  
Includes ANSI/ASHRAE addenda listed in Appendix O

# Ventilation for Acceptable Indoor Air Quality

See Appendix O for approval dates by ASHRAE and the American National Standards Institute.

This Standard is under continuous maintenance by a Standing Standard Project Committee (SSPC) for which the Standards Committee has established a documented program for regular publication of addenda or revisions, including procedures for timely, documented, consensus action on requests for change to any part of the Standard. Instructions for how to submit a change can be found on the ASHRAE® website ([www.ashrae.org/continuous-maintenance](http://www.ashrae.org/continuous-maintenance)).

The latest edition of an ASHRAE Standard may be purchased from the ASHRAE website ([www.ashrae.org](http://www.ashrae.org)) or from ASHRAE Customer Service, 1791 Tullie Circle, NE, Atlanta, GA 30329-2305. E-mail: [orders@ashrae.org](mailto:orders@ashrae.org). Fax: 678-539-2129. Telephone: 404-636-8400 (worldwide), or toll free 1-800-527-4723 (for orders in US and Canada). For reprint permission, go to [www.ashrae.org/permissions](http://www.ashrae.org/permissions).

© 2019 ASHRAE

ISSN 1041-2336



**ASHRAE Standing Standard Project Committee 62.1**  
**Cognizant TC: 4.3, Ventilation Requirements and Infiltration**  
**SPLS Liaison: Karl L. Peterman**  
**ASHRAE Staff Liaison: Mark Weber**

Jennifer A. Isenbeck, *Chair* (2019), *Co-Vice-Chair* (2017–2019)  
 Hoy R. Bohanon, Jr., *Chair* (2016–2019)  
 Wayne R. Thomann, *Vice-Chair* (2019), *Co-Vice-Chair* (2017–2019)

Nick H. Agopian	Henry W. Ernst, Jr.	Meghan K. McNulty	Dennis A. Stanke
Hugo Aguilar	Richard B. Fox	Maria A. Menchaca Brandan	Erica Stewart
William P. Bahnfleth	Enrica Galasso	Christopher O. Muller	Drayton P. Stott
Charlene W. Bayer	Elliott Gall	John Nelson, Jr.	Richard Taft
Robin M. Bristol	Enrique T. Gonzalez	Lisa C. Ng	Dean T. Tompkins
Lance R. Brown	Gregg Gress	Laura G. Petrillo-Groh	David Vigue
Tina M. Brueckner	Brian J. Hafendorfer	Daniel C. Pettway	Ted Wayne
Brendon J. Burley	Nathan L. Ho	Heather L. Platt Gullede	Josiah Wiley
Mark P. Buttner	Elliott Horner	Stephen Ray	Scott D. Williams
Jordan D. Clark	Eli P. Howard, III	Daniel J. Redmond	Donald Weekes, Jr.
Leonard A. Damiano	Zalmie Hussein	Tom Rice	Running Yao
Abdel K. Darwich	Jennifer Kane	Chandra Sekhar	Marwa Zaatari
Helen D. Davis	Paul J. Kitchens	Charles J. Seyffer	
James E. Dennison	Lauren MacGowens	Abhinav Shukla	
Paul L. Doppel	Stephany I. Mason	Jeffrey K. Smith	

**ASHRAE STANDARDS COMMITTEE 2019–2020**

Wayne H. Stoppelmoor, Jr., <i>Chair</i>	Susanna S. Hanson	Lawrence J. Schoen
Drury B. Crawley, <i>Vice-Chair</i>	Rick M. Heiden	Steven C. Sill
Els Baert	Jonathan Humble	Richard T. Swierczyna
Charles S. Barnaby	Srinivas Katipamula	Christian R. Taber
Niels Bidstrup	Essam E. Khalil	Russell C. Tharp
Robert B. Burkhead	Kwang Woo Kim	Adrienne G. Thomle
Thomas E. Cappellin	Larry Kouma	Michael W. Woodford
Douglas D. Fick	Cesar L. Lim	Craig P. Wray
Michael W. Gallagher	Karl L. Peterman	Jaap Hogeling, <i>BOD ExO</i>
Walter T. Grondzik	Erick A. Phelps	Malcolm D. Knight, <i>CO</i>

Steven C. Ferguson, *Senior Manager of Standards*

**SPECIAL NOTE**

This American National Standard (ANS) is a national voluntary consensus Standard developed under the auspices of ASHRAE. *Consensus* is defined by the American National Standards Institute (ANSI), of which ASHRAE is a member and which has approved this Standard as an ANS, as “substantial agreement reached by directly and materially affected interest categories. This signifies the concurrence of more than a simple majority, but not necessarily unanimity. Consensus requires that all views and objections be considered, and that an effort be made toward their resolution.” Compliance with this Standard is voluntary until and unless a legal jurisdiction makes compliance mandatory through legislation.

ASHRAE obtains consensus through participation of its national and international members, associated societies, and public review.

ASHRAE Standards are prepared by a Project Committee appointed specifically for the purpose of writing the Standard. The Project Committee Chair and Vice-Chair must be members of ASHRAE; while other committee members may or may not be ASHRAE members, all must be technically qualified in the subject area of the Standard. Every effort is made to balance the concerned interests on all Project Committees.

The Senior Manager of Standards of ASHRAE should be contacted for

- a. interpretation of the contents of this Standard,
- b. participation in the next review of the Standard,
- c. offering constructive criticism for improving the Standard, or
- d. permission to reprint portions of the Standard.

**DISCLAIMER**

ASHRAE uses its best efforts to promulgate Standards and Guidelines for the benefit of the public in light of available information and accepted industry practices. However, ASHRAE does not guarantee, certify, or assure the safety or performance of any products, components, or systems tested, installed, or operated in accordance with ASHRAE’s Standards or Guidelines or that any tests conducted under its Standards or Guidelines will be nonhazardous or free from risk.

**ASHRAE INDUSTRIAL ADVERTISING POLICY ON STANDARDS**

ASHRAE Standards and Guidelines are established to assist industry and the public by offering a uniform method of testing for rating purposes, by suggesting safe practices in designing and installing equipment, by providing proper definitions of this equipment, and by providing other information that may serve to guide the industry. The creation of ASHRAE Standards and Guidelines is determined by the need for them, and conformance to them is completely voluntary.

In referring to this Standard or Guideline and in marking of equipment and in advertising, no claim shall be made, either stated or implied, that the product has been approved by ASHRAE.

**CONTENTS**  
**ANSI/ASHRAE Standard 62.1-2019**  
**Ventilation for Acceptable Indoor Air Quality**

<b>SECTION</b>	<b>PAGE</b>
Foreword .....	2
1 Purpose .....	2
2 Scope .....	3
3 Definitions .....	3
4 Outdoor Air Quality .....	6
5 Systems and Equipment .....	7
6 Procedures .....	15
7 Construction and System Start-Up .....	30
8 Operations and Maintenance .....	31
9 Normative References .....	34
Normative Appendix A: Multiple-Zone System Ventilation Efficiency: Alternative Procedure .....	36
Normative Appendix B: Separation of Exhaust Outlets and Outdoor Air Intakes .....	40
Normative Appendix C: Zone Air Distribution Effectiveness: Alternate Procedures .....	43
Informative Appendix D: Information on Selected National Standards and Guidelines for PM10, PM2.5, and Ozone .....	45
Informative Appendix E: Acceptable Mass Balance Equations for Use with the IAQ Procedure .....	47
Informative Appendix F: Simplified Ventilation Rate Calculation for Multiple-Zone Recirculating Systems Serving Only Specified Occupancy Categories in Existing Buildings .....	49
Informative Appendix G: Application .....	51
Informative Appendix H: Documentation .....	53
Informative Appendix I: Rate Rationale .....	56
Informative Appendix J: Information on Natural Ventilation .....	64
Informative Appendix K: Compliance .....	67
Informative Appendix L: Ventilation Rate Check Table .....	71
Informative Appendix M: Informative References .....	75
Informative Appendix N: Indoor Air Quality Procedure (IAQP) .....	76
Informative Appendix O: Addenda Description Information .....	81

© 2019 ASHRAE

1791 Tullie Circle NE · Atlanta, GA 30329 · www.ashrae.org · All rights reserved.

ASHRAE is a registered trademark of the American Society of Heating, Refrigerating and Air-Conditioning Engineers, Inc.  
ANSI is a registered trademark of the American National Standards Institute.

**(This foreword is not part of this standard. It is merely informative and does not contain requirements necessary for conformance to the standard. It has not been processed according to the ANSI requirements for a standard and may contain material that has not been subject to public review or a consensus process. Unresolved objectors on informative material are not offered the right to appeal at ASHRAE or ANSI.)**

## FOREWORD

*Standard 62.1 has undergone key changes over the years, reflecting the ever-expanding body of knowledge, experience, and research related to ventilation and air quality. While the purpose of the standard remains unchanged—to specify minimum ventilation rates and other measures intended to provide indoor air quality (IAQ) that is acceptable to human occupants and that minimizes adverse health effects—the means of achieving this goal have evolved.*

*In its first edition, the standard adopted a prescriptive approach to ventilation by specifying both minimum and recommended outdoor airflow rates to obtain acceptable indoor air quality for a variety of indoor spaces. In 1981, the standard reduced minimum outdoor airflow rates and introduced an alternative performance-based approach, the IAQ Procedure, which allowed for the calculation of the amount of outdoor air necessary to maintain the levels of indoor air contaminants below recommended limits. In 2004—the last time the standard was revised in its entirety—the IAQ Procedure was modified to improve enforceability, but more significantly the Ventilation Rate Procedure was modified, changing both the minimum outdoor airflow rates and the procedures for calculating both zone-level and system-level outdoor airflow rates. Today, the standard includes three procedures for ventilation design: the IAQ Procedure, the Ventilation Rate Procedure, and the Natural Ventilation Procedure.*

*The following are among significant changes made in the 2019 edition of the standard:*

- *The scope is changed to remove commentary and to more specifically identify occupancies previously not covered.*
- *Informative tables of ventilation rates per unit area are included for checking existing buildings and design of new buildings.*
- *The Ventilation Rate Procedure is modified with a new simplified version for determining  $E_v$ , and a more robust option for determining values of  $E_z$ .*
- *The Natural Ventilation Procedure is significantly modified to provide a more accurate calculation methodology and also define the process for designing an engineered system.*
- *Natural ventilation now requires considering the quality of the outdoor air and interaction of the outdoor air with mechanically cooled spaces.*
- *Air-cleaning devices that generate ozone are prohibited.*
- *Humidity control requirements are now expressed as dew point and not as relative humidity.*
- *The standard now defers to ANSI Z9.5 on ventilation for laboratories handling hazardous materials.*
- *Patient care spaces in the scope of ASHRAE/ASHE Standard 170 now follow the requirements of Standard 170; ancillary spaces not previously classified have been added.*

*For more specific information on these and other changes made to the standard, refer to Informative Appendix O.*

*Standard 62.1 is updated on a regular basis using ASHRAE's continuous maintenance procedures. Addenda are publicly reviewed, approved by ASHRAE and ANSI, and posted on the ASHRAE website. Change proposals can be submitted online at [www.ashrae.org/continuous-maintenance](http://www.ashrae.org/continuous-maintenance). The project committee for Standard 62.1 takes formal action on all change proposals received.*

## 1. PURPOSE

**1.1** The purpose of this standard is to specify minimum ventilation rates and other measures intended to provide indoor air quality (IAQ) that is acceptable to human occupants and that minimizes adverse health effects.

**1.2** This standard is intended for regulatory application to new buildings, additions to existing buildings, and those changes to existing buildings that are identified in the body of the standard.

**1.3** This standard is intended to be used to guide the improvement of IAQ in existing buildings.

## 2. SCOPE

- 2.1** This standard applies to spaces intended for human occupancy within buildings except those within dwelling units in residential occupancies in which occupants are nontransient.
- 2.2** This standard defines requirements for ventilation and air-cleaning system design, installation, commissioning, and operation and maintenance.
- 2.3** In addition to ventilation, this standard contains requirements related to certain contaminants and contaminant sources, including outdoor air, construction processes, moisture, and biological growth.
- 2.4** This standard does not prescribe specific ventilation rate requirements for the following:
- Spaces that contain smoking or that do not meet the requirements in the standard for separation from spaces that contain smoking
  - Patient care areas not listed in this standard
  - Laboratories with hazardous materials

## 3. DEFINITIONS

### 3.1 Terminology (See Figure 3-1)

**acceptable indoor air quality (IAQ):** air in which there are no known contaminants at harmful concentrations, as determined by cognizant authorities, and with which a substantial majority (80% or more) of the people exposed do not express dissatisfaction.

**air:**

**ambient air:** the air surrounding a building; the source of outdoor air brought into a building.

**cool air:** air whose temperature is less than the average space temperature.

**exhaust air:** air removed from a space and discharged to outside the building by means of mechanical or natural ventilation systems.

**indoor air:** the air in an enclosed occupiable space.

**makeup air:** any combination of outdoor and transfer air intended to replace exhaust air and exfiltration.

**outdoor air:** ambient air and ambient air that enters a building through a ventilation system, through intentional openings for natural ventilation, or by infiltration.

**primary air:** air supplied to the ventilation zone prior to mixing with any locally recirculated air.

**recirculated air:** air removed from a space and reused as supply air.

**return air:** air removed from a space to be recirculated or exhausted.

**supply air:** air delivered by mechanical or natural ventilation to a space and composed of any combination of outdoor air, recirculated air, or transfer air.

**transfer air:** air moved from one indoor space to another.

**ventilation air:** that portion of supply air that is outdoor air plus any recirculated air that has been treated for the purpose of maintaining acceptable IAQ.

**warm air:** air whose temperature is greater than the average space temperature.

**air-cleaning system:** a device or combination of devices applied to reduce the concentration of airborne contaminants such as microorganisms, dusts, fumes, respirable particles, other particulate matter, gases, vapors, or any combination thereof.

**air conditioning:** the process of treating air to meet the requirements of a conditioned space by controlling its temperature, humidity, cleanliness, and distribution.

**breathing zone:** the region within an occupied space between planes 3 and 72 in. (75 and 1800 mm) above the floor and more than 2 ft (600 mm) from the walls or fixed air-conditioning equipment.

**ceiling return:** air removed from the space more than 4.5 ft (1.4 m) above the floor.

**ceiling supply:** air supplied to the space more than 4.5 ft (1.4 m) above the floor.

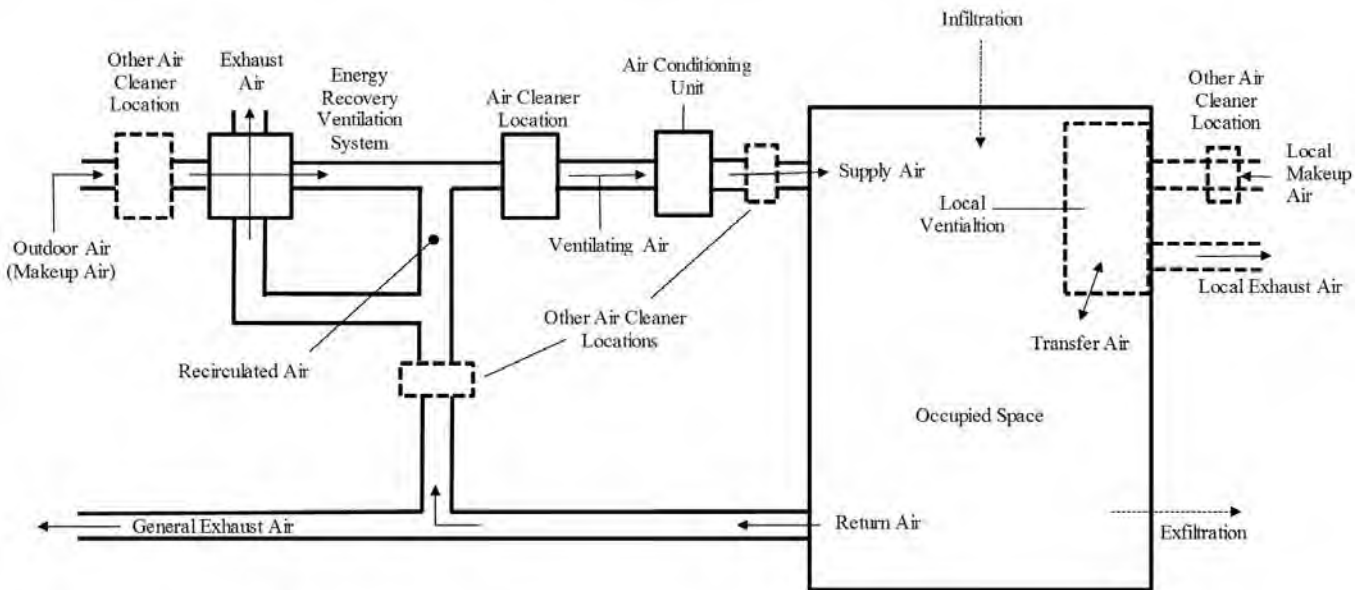

**Figure 3-1 Ventilation system.**

**classroom:** a space for instruction in which the instructor regularly occupies and stores supplies in the space.

**lecture classroom:** a space for instruction in which all occupants are interim and no supplies are stored in the space.

**cognizant authority:** an agency or organization that has the expertise and jurisdiction to establish and regulate concentration limits for airborne contaminants, or an agency or organization that is recognized as authoritative and has the scope and expertise to establish guidelines, limit values, or concentrations levels for airborne contaminants.

**concentration:** the quantity of one constituent dispersed in a defined amount of another.

**conditioned space:** that part of a building that is heated or cooled or both for the comfort of occupants.

**contaminant:** an unwanted airborne constituent with the potential to reduce acceptability of the air.

**contaminant mixture:** two or more contaminants that target the same organ system.

**demand controlled ventilation (DCV):** any means by which the breathing zone outdoor air-flow ( $V_{bz}$ ) can be varied to the occupied space or spaces based on the actual or estimated number of occupants, ventilation requirements of the occupied zone, or both.

**dwelling unit:** a single unit providing complete, independent living facilities for one or more persons, including permanent provisions for living, sleeping, eating, cooking, and sanitation.

**energy recovery ventilation system:** a device or combination of devices applied to provide the outdoor air for ventilation in which energy is transferred between the intake and exhaust air-streams.

**environmental tobacco smoke (ETS):** the “aged” and diluted combination of both side-stream smoke (smoke from the lit end of a cigarette or other tobacco product) and exhaled mainstream smoke (smoke that is exhaled by a smoker). ETS is commonly referred to as *secondhand smoke*. This definition includes smoke produced from the combustion of cannabis and controlled substances and the emissions produced by electronic smoking devices.

**equipment well:** an area (typically on the roof) enclosed on three or four sides by walls that are less than 75% free area, and the lesser of the length and width of the enclosure is less than three times the average height of the walls. The free area of the wall is the ratio of area of the openings through the wall, such as openings between louver blades and undercuts, divided by the gross area (length times height) of the wall.



**ETS area:** spaces where smoking is permitted, as well as those spaces not separated from spaces where smoking is permitted in accordance with the requirements of Section 5 in this standard.

**ETS-free area:** an area where no smoking occurs and that is separated from ETS areas according to the requirements of this standard. (*Informative Note:* A no-smoking area is not necessarily an ETS-free area.)

**exfiltration:** uncontrolled outward air leakage from conditioned spaces through unintentional openings in ceilings, floors, and walls to unconditioned spaces or the outdoors caused by pressure differences across these openings due to wind, inside-outside temperature differences (stack effect), and imbalances between outdoor and exhaust airflow rates.

**floor return:** air removed from the space less than 4.5 ft (1.4 m) above the floor.

**floor supply:** air supplied to the space less than 4.5 ft (1.4m) above the floor.

**hazardous materials:** any biological, chemical, radiological, or physical item or agent that has the potential to cause harm to humans, animals, or the environment, either by itself or through interaction with other factors. Hazardous chemicals are any chemicals that are classified as a health hazard or simple asphyxiant, in accordance with the Hazard Communication Standard (29 CFR 1910.1200), and any other particularly hazardous substances, including select carcinogens, reproductive toxins, and substances that have a high degree of acute toxicity. Hazardous biological agents are any pathogenic, allergenic, or toxigenic microorganisms, including BSL2-4 agents as defined in the National Institute for Health's *Biosafety in Microbiological and Biomedical Laboratories*.

**imaging room, Class 1:** imaging rooms that meet the criterion of Class 1 as per the FGI *Guidelines for Design and Construction of Outpatient Facilities*, Table 2.1-5.6.2.5.1.3.

**industrial space:** an indoor environment where the primary activity is production or manufacturing processes.

**infiltration:** uncontrolled inward air leakage to conditioned spaces through unintentional openings in ceilings, floors, and walls from unconditioned spaces or the outdoors caused by the same pressure differences that induce exfiltration.

**mechanical ventilation:** ventilation provided by mechanically powered equipment such as motor-driven fans and blowers but not by devices such as wind-driven turbine ventilators and mechanically operated windows.

**microorganism:** a microscopic organism, especially a bacterium, fungus, or protozoan.

**natural ventilation:** ventilation provided by thermal, wind, or diffusion effects through doors, windows, or other intentional openings in the building.

**net occupiable area:** the floor area of an occupiable space defined by the inside surfaces of its walls but excluding shafts, column enclosures, and other permanently enclosed, inaccessible, and unoccupiable areas. Obstructions in the space, such as furnishings, display or storage racks, and other obstructions, whether temporary or permanent, are considered to be part of the net occupiable area.

**nontransient:** occupancy of a dwelling unit or sleeping unit for more than 30 days.

**occupant sensor:** a device such as a motion detector or a captive key system that detects the presence of one or more persons within a space.

**occupiable space:** an enclosed space intended for human activities excluding spaces that are intended to be occupied occasionally and for short periods of time, such as storage rooms, equipment rooms, and emergency exitways.

**occupied mode:** when a zone is scheduled to be occupied.

**occupied standby mode:** when a zone is scheduled to be occupied and an occupant sensor indicates zero population within the zone.

**odor:** a quality of gases, liquids, or particles that stimulates the olfactory organ.

**openable area:** the net free area of an opening.

**patient care area:** an area used primarily for the provision of clinical care to patients. Such care includes monitoring, evaluation, and treatment services.

**readily accessible:** capable of being reached quickly for operation without requiring personnel to climb over or remove obstacles or to resort to the use of unsafe climbing aids such as tables or chairs.

**residential occupancies:** occupancies that are not classified as institutional by the authority having jurisdiction (AHJ) and that contain permanent provisions for sleeping.

**sleeping unit:** a room or space in which people sleep that includes permanent provisions for living, eating, and either sanitation or kitchen facilities but not both. Such rooms and spaces that are also part of a dwelling unit are not sleeping units.

**stratified air distribution system:** a device or combination of devices applied to provide a stratified thermal and pollutant distribution within a zone.

**unoccupied mode:** when a zone is not scheduled to be occupied.

**unusual source:** an item or activity that could create or emit contaminants that occurs rarely within an occupancy category.

**ventilation:** the process of supplying air to or removing air from a space for the purpose of controlling air contaminant levels, humidity, or temperature within the space.

**ventilation zone:** any indoor area that requires ventilation and comprises one or more spaces with the same occupancy category (see Table 6-1), occupant density, zone air distribution effectiveness (see Section 6.2.1.2), and design zone primary airflow (see Section 6.2.4.3.2 and Normative Appendix A) per unit area. (**Informative Note:** A ventilation zone is not necessarily an independent thermal control zone; however, spaces that can be combined for load calculation purposes can often be combined into a single zone for ventilation calculations purposes.)

**volume, space:** the total volume of an occupiable space enclosed by the building envelope, plus that of any spaces permanently open to the occupiable space, such as a ceiling attic used as a ceiling return plenum.

**zone air distribution effectiveness:** the ratio of the change of contaminant concentration between the air supply and air exhaust to the change of contaminant concentration between the air supply and the breathing zone.

## 4. OUTDOOR AIR QUALITY

Outdoor air quality shall be investigated in accordance with Sections 4.1 and 4.2 prior to completion of ventilation system design. The results of this investigation shall be documented in accordance with Section 4.3.

**4.1 Regional Air Quality.** The status of compliance with national ambient air quality standards shall be determined for the geographic area of the building site.

**4.1.1** In the United States, compliance status shall be either in “attainment” or “nonattainment” with the National Ambient Air Quality Standards (NAAQS). In the United States, areas with no U.S. Environmental Protection Agency (USEPA) compliance status designation shall be considered “attainment” areas.

### **Informative Notes:**

1. The NAAQS are shown in Table D-1 of Informative Appendix D.
2. The USEPA list of nonattainment areas can be found at [www.epa.gov/green-book](http://www.epa.gov/green-book).
3. Air quality data collected at outdoor monitors across the U.S. can be found at [www.epa.gov/outdoor-air-quality-data](http://www.epa.gov/outdoor-air-quality-data).
4. Internet links to detailed information on the NAAQS and contaminant levels for other select counties and regions can be found in Informative Appendix D.

**4.2 Local Air Quality.** An observational survey of the building site and its immediate surroundings shall be conducted during hours the building is expected to be normally occupied to identify local contaminants from surrounding facilities that will be of concern if allowed to enter the building.

**4.3 Documentation.** Documentation of the outdoor air quality investigation shall be reviewed with building owners or their representative and shall include the following as a minimum:



- a. Regional air quality compliance status
- b. Local survey information
  1. Date of observations
  2. Time of observations
  3. Site description
  4. Description of facilities on site and on adjoining properties
  5. Observation of odors or irritants
  6. Observation of visible plumes or visible air contaminants
  7. Description of sources of vehicle exhaust on site and on adjoining properties
  8. Identification of potential contaminant sources on the site and from adjoining properties, including any that operate only seasonally
- c. Conclusion regarding the acceptability of outdoor air quality and the information supporting the conclusion

## 5. SYSTEMS AND EQUIPMENT

**5.1 Ventilation Air Distribution.** Ventilating systems shall be designed in accordance with the requirements of the following subsections.

**5.1.1 Designing for Air Balancing.** Ventilation air distribution systems shall be provided that allow field verification of outdoor air intake flow ( $V_{oi}$ ) during operation.

**5.1.1.1 Designing for Varying Loads and Operating Conditions.** The ventilation air distribution system for variable air volume (VAV) and multispeed constant air volume (CAV) applications shall be provided with means to adjust the system to achieve at least the minimum ventilation airflow as required by Section 6 under any load condition or dynamic reset condition.

**5.1.2 Plenum Systems.** When the ceiling or floor plenum is used both to recirculate return air and to distribute ventilation air to ceiling-mounted or floor-mounted terminal units, the system shall be engineered such that each space is provided with its required minimum ventilation airflow.

**Informative Note:** Systems with direct connection of ventilation air ducts to terminal units, for example, comply with this requirement.

**5.1.3 Documentation.** The design documents shall specify minimum requirements for air balance testing or reference applicable national standards for measuring and balancing airflow. The design documentation shall state assumptions that were made in the design with respect to ventilation rates and air distribution.

## 5.2 Exhaust Duct Location

**5.2.1** Exhaust ducts that convey Class 4 air shall be negatively pressurized relative to ducts, plenums, or occupiable spaces through which the ducts pass.

**5.2.2** Exhaust ducts under positive pressure that convey Class 2 or Class 3 air shall not extend through ducts, plenums, or occupiable spaces other than the space from which the exhaust air is drawn.

**Exception to 5.2.2:** Exhaust ducts conveying Class 2 air and exhaust ducts conveying air from residential kitchen hoods that are sealed in accordance with SMACNA Seal Class A.

**5.3 Ventilation System Controls.** Mechanical ventilation systems shall include controls in accordance with the following subsections.

**5.3.1** All systems shall be provided with manual or automatic controls to maintain not less than the outdoor air intake flow ( $V_{oi}$ ) required by Section 6 under all load conditions or dynamic reset conditions.

**5.3.2** Systems with fans supplying variable primary air ( $V_{ps}$ ) shall be provided with any combination of control equipment, methods, or devices to maintain no less than the outdoor air intake flow ( $V_{oi}$ ) required for compliance with Section 5.3.1.

**5.4 Airstream Surfaces.** All airstream surfaces in equipment and ducts in the HVAC system shall be designed and constructed in accordance with the requirements of the following subsections.

**Table 5-1 Air Intake Minimum Separation Distance**

Object	Minimum Distance, ft (m)
Class 2 air exhaust/relief outlet	10 (3)
Class 3 air exhaust/relief outlet	15 (5)
Class 4 air exhaust/relief outlet	30 (10)
Cooling tower exhaust	25 (7.5)
Cooling tower intake or basin	15 (5)
Driveway, street, or parking place	5 (1.5)
Garage entry, automobile loading area, or drive-in queue	15 (5)
Garbage storage/pick-up area, dumpsters	15 (5)
Plumbing vents terminating at least 3 ft (1 m) above the level of the outdoor air intake	3 (1)
Plumbing vents terminating less than 3 ft (1 m) above the level of the outdoor air intake	10 (3)
Roof, landscaped grade, or other surface directly below intake	1 (0.30)
Thoroughfare with high traffic volume	25 (7.5)
Truck loading area or dock, bus parking/idling area	25 (7.5)
Vents, chimneys, and flues from combustion appliances and equipment	15 (5)

**5.4.1 Resistance to Mold Growth.** Material surfaces shall be determined to be resistant to mold growth in accordance with a standardized test method, such as the mold growth and humidity test in UL 181, ASTM C1338, or ASTM D3273.

**Exception to 5.4.1:** Sheet metal surfaces and metal fasteners.

**Informative Note:** Even with this resistance, any airstream surface that is continuously wetted is still subject to microbial growth.

**5.4.2 Resistance to Erosion.** Airstream surface materials shall be evaluated in accordance with the erosion test in UL 181 and shall not break away, crack, peel, flake off, or show evidence of delamination or continued erosion under test conditions.

**Exception to 5.4.2:** Sheet metal surfaces and metal fasteners.

**5.5 Outdoor Air Intakes.** Ventilation system outdoor air intakes shall be designed in accordance with the following subsections.

**5.5.1 Location.** Outdoor air intakes (including openings that are required as part of a natural ventilation system) shall be located such that the shortest distance from the intake to any specific potential outdoor contaminant source listed in Table 5-1 shall be equal to or greater than

- a. the separation distance in Table 5-1 or
- b. the calculation methods in Normative [Appendix B](#)

and shall comply with all other requirements of this section.

**5.5.1.1 Exhaust/Relief Outlets.** Separation criteria for Class 2 and Class 3 exhaust/relief outlets apply to the distance from the outdoor air intakes for one ventilation system to the exhaust outlets and relief outlets for any other ventilation system.

**5.5.1.2 Fuel-Burning Equipment.** The minimum distances relative to fuel-fired appliances shall be as required by ANSI Z223.1/NFPA 54 for fuel-gas-burning appliances and equipment, NFPA 31 for oil-burning appliances and equipment, and NFPA 211 for other combustion appliances and equipment.

**5.5.1.3 Roof, Landscaped Grade, or Another Surface Directly Below Intake.** Where snow accumulation is expected, the surface of the snow at the expected average snow depth shall be considered to be a surface directly below an intake.

**Exception to 5.5.1.3:** The minimum separation distance in Table 5-1 shall not apply where outdoor surfaces below the air intake are sloped more than 45 degrees from horizontal or where such surfaces are less than 1 in. (30 mm) in width.

**5.5.1.4 Laboratory Exhaust.** Separation criteria for fume hood exhaust shall be in compliance with ANSI/AIHA Z9.5.

**5.5.2 Rain Entrainment.** Outdoor air intakes that are part of the mechanical ventilation system shall be designed to manage rain entrainment in accordance with one or more of the following:

- a. Limit water penetration through the intake to 0.07 oz/ft<sup>2</sup>·h (21.5 g/m<sup>2</sup>·h) of inlet area when tested using the rain test apparatus described in UL 1995, Section 58.
- b. Select louvers that limit water penetration to a maximum of 0.01 oz/ft<sup>2</sup> (3 g/m<sup>2</sup>) of louver free area at the maximum intake velocity. This water penetration rate shall be determined for a minimum 15 minute test duration when subjected to a water flow rate of 0.25 gal/min (16 mL/s) as described under the water penetration test in AMCA 500-L or equivalent. Manage the water that penetrates the louver by providing a drainage area or moisture removal devices.
- c. Select louvers that restrict wind-driven rain penetration to less than 2.36 oz/ft<sup>2</sup>·h (721 g/m<sup>2</sup>·h) when subjected to a simulated rainfall of 3 in. (75 mm) per hour and a 29 mph (13 m/s) wind velocity at the design outdoor air intake rate with the air velocity calculated based on the louver face area. (**Informative Note:** This performance corresponds to Class A (99% effectiveness) when rated according to AMCA 511 and tested per AMCA 500-L.)
- d. Use rain hoods sized for no more than 500 fpm (2.5 m/s) face velocity with a downward-facing intake such that all intake air passes upward through a horizontal plane that intersects the solid surfaces of the hood before entering the system.
- e. Manage the water that penetrates the intake opening by providing a drainage area or moisture removal devices.

**5.5.3 Rain Intrusion.** Air-handling and distribution equipment mounted outdoors shall be designed to prevent rain intrusion into the airstream when tested at design airflow and with no airflow, using the rain test apparatus described in UL 1995, Section 58.

**5.5.4 Snow Entrainment.** Where climate dictates, outdoor air intakes that are part of the mechanical ventilation system shall be designed as follows to manage water from snow that is blown or drawn into the system:

- a. Access doors to permit cleaning of wetted surfaces shall be provided.
- b. Outdoor air ductwork or plenums shall pitch to drains designed in accordance with the requirements of Section 5.12.

**5.5.5 Bird Screens.** Outdoor air intakes shall include a screening device designed to prevent penetration by a 0.5 in. (13 mm) diameter probe. The screening device material shall be corrosion resistant. The screening device shall be located, or other measures shall be taken, to prevent bird nesting within the outdoor air intake.

**Informative Note:** Any horizontal surface may be subject to bird nesting.

**5.6 Local Capture of Contaminants.** The discharge from noncombustion equipment that captures the contaminants generated by the equipment shall be ducted directly to the outdoors.

**Exception to 5.6:** Equipment specifically designed for discharge indoors in accordance with the manufacturer recommendations.

**5.7 Ozone Generating Devices.** The use of ozone generating devices shall comply with the following sections.

**Exception to 5.7:** Electronic devices used exclusively for the operation of HVAC equipment and controls.

**Informative Note:** Ozone generation is expected from ozone generators, corona discharge technology, some ultraviolet lights, electronic devices that create chemical reactions within the system, and some devices using a high voltage (>480 V). Motors and relays are examples of electronic devices that would be exempt.

**5.7.1 Air-Cleaning Devices.** Air-cleaning devices shall be listed and labeled in accordance with UL 2998.

**Informative Note:** The use of devices not intended for air cleaning with the potential to generate ozone should be avoided.

**5.7.2 Ultraviolet Devices.** Ultraviolet generating devices in supply air or spaces shall not transmit 185 nm wavelengths.

**Informative Note:** Ultraviolet devices used in treatment of closed water systems may produce 185 nm wavelengths, which may generate ozone.

**5.8 Combustion Air.** Fuel-burning appliances, both vented and unvented, shall be provided with air for combustion and removal of combustion products in accordance with manufacturer instructions. Products of combustion from vented appliances shall be vented directly outdoors.

**5.9 Particulate Matter Removal.** Particulate matter filters or air cleaners having either

- a. a MERV of not less than 8 where rated in accordance with [ASHRAE Standard 52.2](#) or
- b. the minimum efficiency within ISO ePM10 where rated in accordance with ISO 16890

shall be provided upstream of all cooling coils or other devices with wetted surfaces through which air is supplied to an occupiable space.

**Exception to 5.9:** Cooling coils that are designed, controlled, and operated to provide sensible cooling only.

**5.10 Maximum Indoor Air Dew Point in Mechanically Cooled Buildings.** Buildings or spaces equipped with or served by mechanical cooling equipment shall be provided with dehumidification components and controls that limit the indoor humidity to a maximum dew point of 60°F (15°C) during both occupied and unoccupied hours whenever the outdoor air dew point is above 60°F (15°C). The dew-point limit shall not be exceeded when system performance is analyzed with outdoor air at the dehumidification design condition (that is, design dew point and mean coincident dry-bulb temperatures) and with the space interior loads (both sensible and latent) at cooling design values and space solar loads at zero.

**Exceptions to 5.10:**

1. Buildings or spaces that are neither equipped with nor served by mechanical cooling equipment.
2. Buildings or spaces equipped with materials, assemblies, coatings, and furnishings that resist microbial growth and that are not damaged by continuously high indoor air dew points.
3. During overnight unoccupied periods not exceeding 12 hours, the 60°F (15°C) dew-point limit shall not apply, provided that indoor relative humidity does not exceed 65% at any time during those hours.

**Informative Notes:**

1. Examples of spaces are shower rooms, swimming pool enclosures, kitchens, spa rooms, or semicooled warehouse spaces that contain stored contents that are not damaged by continuously high indoor air dew points or microbial growth.
2. This requirement reduces the risk of microbial growth in buildings and their interstitial spaces because it limits the mass of indoor water vapor that can condense or be absorbed into mechanically cooled surfaces. The dew-point limit is explicitly extended to unoccupied hours because of the extensive public record of mold growth in schools, apartments, dormitories, and public buildings that are intermittently cooled during unoccupied hours when the outdoor air dew point is above 60°F (15°C).

**5.11 Building Exfiltration.** Ventilation systems for a building equipped with or served by mechanical cooling equipment shall be designed such that the total building outdoor air intake equals or exceeds the total building exhaust under all load and dynamic reset conditions.

**Exceptions to 5.11:**

1. Where an imbalance is required by process considerations and approved by the authority having jurisdiction (AHJ), such as in certain industrial facilities.
2. When outdoor air dry-bulb temperature is below the indoor space dew-point design temperature.

**Informative Note:** Although individual zones within a building may be neutral or negative with respect to outdoors or to other zones, net positive mechanical intake airflow for the building as a whole reduces infiltration of untreated outdoor air.

**5.12 Drain Pans.** Drain pans, including their outlets and seals, shall be designed and constructed in accordance with this section.

**5.12.1 Drain Pan Slope.** Pans intended to collect and drain liquid water shall be sloped at least 0.125 in./ft (10 mm/m) from the horizontal toward the drain outlet or shall be otherwise designed such that water drains freely from the pan whether the fan is ON or OFF.

**5.12.2 Drain Outlet.** The drain pan outlet shall be located at the lowest point(s) of the drain pan and shall be sized to preclude drain pan overflow under any normally expected operating condition.

**5.12.3 Drain Seal.** For configurations that result in negative static pressure at the drain pan relative to the drain outlet (such as a draw-through unit), the drain line shall include a P-trap or other sealing device designed to maintain a seal against ingestion of ambient air, while allowing complete drainage of the drain pan under any normally expected operating condition, whether the fan is ON or OFF.

**5.12.4 Pan Size.** The drain pan shall be located under the water producing device. Drain pan width shall be sized to collect water droplets across the entire width of the water producing device or assembly. For horizontal airflow configurations, the drain pan length shall begin at the leading face or edge of the water producing device or assembly and extend downstream from the leaving face or edge to a distance of either

- a. one half of the installed vertical dimension of the water producing device or assembly or
- b. as necessary to limit water droplet carryover beyond the drain pan to 0.0044 oz/ft<sup>2</sup> (1.5 mL/m<sup>2</sup>) of face area per hour under peak sensible and peak dew-point design conditions, accounting for both latent load and coil face velocity.

### 5.13 Finned-Tube Coils and Heat Exchangers

**5.13.1 Drain Pans.** A drain pan, in accordance with Section 5.12, shall be provided beneath all dehumidifying cooling-coil assemblies and all condensate producing heat exchangers.

**5.13.2 Finned-Tube-Coil Selection for Cleaning.** Individual finned-tube coils or multiple finned-tube coils in series without intervening access spaces of at least 18 in. (457 mm) shall be selected to result in no more than 0.75 in. of water (187 Pa) combined dry-coil pressure drop at 500 fpm (2.54 m/s) face velocity.

**5.14 Humidifiers and Water Spray Systems.** Steam and direct-evaporative humidifiers, air washers, direct-evaporative coolers, and other water spray systems shall be designed in accordance with this section.

**5.14.1 Water Quality.** Water purity shall meet or exceed potable water standards at the point where it enters the ventilation system, space, or water vapor generator. Water vapor generated shall contain no chemical additives other than those chemicals in a potable water system.

#### Exceptions to 5.14.1:

1. Water spray systems that use chemical additives that meet NSF/ANSI Standard 60, *Drinking Water Treatment Chemicals—Health Effects*.
2. Boiler water additives that meet the requirements of 21 CFR 173.310, *Secondary Direct Food Additives Permitted In Food For Human Consumption*, and include automated dosing devices.

**5.14.2 Obstructions.** Air cleaners or ductwork obstructions, such as turning vanes, volume dampers, and duct offsets greater than 15 degrees, that are installed downstream of humidifiers or water spray systems shall be located a distance equal to or greater than the absorption distance recommended by the humidifier or water spray system manufacturer.

**Exception 5.14.2:** Equipment such as eliminators, coils, or evaporative media shall be permitted to be located within the absorption distance recommended by the manufacturer, provided a drain pan complying with the requirements of Section 5.12 is used to capture and remove any water that drops out of the airstream due to impingement on these obstructions.

### 5.15 Access for Inspection, Cleaning, and Maintenance

**5.15.1 Equipment Clearance.** Ventilation equipment shall be installed with working space that will allow for inspection and routine maintenance, including filter replacement and fan belt adjustment and replacement.

**5.15.2 Ventilation Equipment Access.** Access doors, panels, or other means shall be provided and sized to allow unobstructed access for inspection, maintenance, and calibration of all ventilation system components for which routine inspection, maintenance, or calibration is necessary. Ventilation system components include air-handling units, fan-coil units, water-source heat pumps, other terminal units, controllers, and sensors.

**5.15.3 Air Distribution System.** Access doors, panels, or other means shall be provided in ventilation equipment, ductwork, and plenums, located and sized to allow convenient and unobstructed access for inspection, cleaning, and routine maintenance of the following:

- a. Outdoor air intake areaways or plenums
- b. Mixed-air plenums
- c. Upstream surface of each heating, cooling, and heat-recovery coil or coil assembly having a total of four rows or fewer
- d. Both upstream and downstream surface of each heating, cooling, and heat-recovery coil having a total of more than four rows, and air washers, evaporative coolers, heat wheels, and other heat exchangers
- e. Air cleaners
- f. Drain pans and drain seals
- g. Fans
- h. Humidifiers

**5.16 Building Envelope and Interior Surfaces.** The building envelope and interior surfaces within the building envelope shall be designed in accordance with the following subsections.

**5.16.1 Building Envelope.** The building envelope, including roofs, walls, fenestration systems, and foundations, shall comply with the following:

- a. A weather barrier or other means shall be provided to prevent liquid-water penetration into the envelope.

**Exception to 5.16.1(a):** When the envelope is engineered to allow incidental water penetration to occur without resulting in damage to the envelope construction.

- b. An appropriately placed vapor retarder or other means shall be provided to limit water vapor diffusion to prevent condensation on cold surfaces within the envelope.

**Exception to 5.16.1(b):** When the envelope is engineered to manage incidental condensation without resulting in damage to the envelope construction.

- c. Exterior joints, seams, or penetrations in the building envelope that are pathways for air leakage shall be caulked, gasketed, weather stripped, provided with a continuous air barrier, or otherwise sealed to limit infiltration through the envelope to reduce uncontrolled entry of outdoor air moisture and pollutants.

**Informative Note:** In localities where soils contain high concentrations of radon or other soil-gas contaminants, the AHJ might impose additional measures such as subslab depressurization.

**5.16.2 Condensation on Interior Surfaces.** Pipes, ducts, and other surfaces within the building whose surface temperatures are expected to fall below the surrounding dew-point temperature shall be insulated. The insulation system thermal resistance and material characteristics shall prevent condensate from forming on the exposed surface and within the insulating material.

**Exception to 5.16.2:** Where condensate will wet only surfaces that will be managed to prevent or control mold growth. A management plan must be submitted along with the design specifying design assumptions and limits of the plan. The plan must be provided to the owner.

**5.17 Buildings with Attached Parking Garages.** In order to limit the entry of vehicular exhaust into occupiable spaces, buildings with attached parking garages shall be designed to

- a. maintain the garage pressure at or below the pressure of the adjacent occupiable spaces,
- b. use a vestibule to provide an airlock between the garage and the adjacent occupiable spaces, or
- c. otherwise limit migration of air from the attached parking garage into the adjacent occupiable spaces of the building in a manner acceptable to the AHJ.

**5.18 Air Classification and Recirculation.** Air shall be classified, and its recirculation shall be limited in accordance with the following subsections.



**5.18.1 Classification.** Air (return, transfer, or exhaust air) leaving each space or location shall be designated at an expected air-quality classification not less than that shown in Table 6-1, 6-2, or 6-3 or as approved by the AHJ. Air leaving spaces or locations that are not listed in Table 6-1, 6-2, or 6-3 shall be designated with the same classification as air from the most similar space or location listed in terms of occupant activities and building construction.

**Exception to 5.18.1:** Air from spaces where environmental tobacco smoke (ETS) is present. (Classification of air from spaces where ETS is present is not addressed. Spaces that are expected to include ETS do not have a classification listed in Table 6-1.)

**Informative Note:** Classifications in Tables 6-1, 6-2, and 6-3 are based on relative contaminant concentration using the following subjective criteria:

1. Class 1: Air with low contaminant concentration, low sensory-irritation intensity, and inoffensive odor.
2. Class 2: Air with moderate contaminant concentration, mild sensory-irritation intensity, or mildly offensive odors. (Class 2 air also includes air that is not necessarily harmful or objectionable but that is inappropriate for transfer or recirculation to spaces used for different purposes.)
3. Class 3: Air with significant contaminant concentration, significant sensory-irritation intensity, or offensive odor.
4. Class 4: Air with highly objectionable fumes or gases or with potentially dangerous particles, bioaerosols, or gases, at concentrations high enough to be considered as harmful.

### 5.18.2 Redesignation

**5.18.2.1 Air Cleaning.** If air leaving a space or location passes through an air-cleaning system, redesignation of the cleaned air to a cleaner classification shall be permitted per the following requirements:

- a. Class 2 air where based on the subjective criteria in the informative note for Section 5.18.1 and where approved by the AHJ.
- b. Class 3 and Class 4 air when all requirements of Sections 6.3.1 through 6.3.4 are followed.

**5.18.2.2 Transfer.** A mixture of air that has been transferred through or returned from spaces or locations with different air classes shall be redesignated with the highest classification among the air classes mixed.

**Informative Note:** For example, mixed return air to a common system serving both a Class 1 space and a Class 2 space is designated as Class 2 air.

**5.18.2.3 Ancillary Spaces.** Redesignation of Class 1 air to Class 2 air shall be permitted for Class 1 spaces that are ancillary to Class 2 spaces.

**Informative Note:** For example, an office within a restaurant might be designated as a space ancillary to a Class 2 space, thus enabling the office to receive Class 2 air.

**5.18.3 Recirculation Limitations.** When the Ventilation Rate Procedure of Section 6 is used to determine ventilation airflow values, recirculation of air shall be limited in accordance with the requirements of this section.

**5.18.3.1 Class 1 Air.** Recirculation or transfer of Class 1 air to any space shall be permitted.

#### 5.18.3.2 Class 2 Air

**5.18.3.2.1** Recirculation of Class 2 air within the space of origin shall be permitted.

**5.18.3.2.2** Recirculation or transfer of Class 2 air to other Class 2 or Class 3 spaces shall be permitted, provided that the other spaces are used for the same or similar purpose or task and involve the same or similar pollutant sources as the Class 2 space.

**5.18.3.2.3** Transfer of Class 2 air to toilet rooms shall be permitted.

**5.18.3.2.4** Recirculation or transfer of Class 2 air to Class 4 spaces shall be permitted.

**5.18.3.2.5** Class 2 air shall not be recirculated or transferred to Class 1 spaces.

**Exception to 5.18.3.2.5:** When using any energy recovery device, recirculation from leakage, carryover, or transfer from the exhaust side of the energy recovery device is permitted. Recirculated Class 2 air shall not exceed 10% of the outdoor air intake flow.

#### 5.18.3.3 Class 3 Air

**5.18.3.3.1** Recirculation of Class 3 air within the space of origin shall be permitted.

**5.18.3.3.2** Class 3 air shall not be recirculated or transferred to any other space.

**Exception to 5.18.3.3.2:** When using any energy recovery device, recirculation from leakage, carryover, or transfer from the exhaust side of the energy recovery device is permitted. Recirculated Class 3 air shall not exceed 5% of the outdoor air intake flow.

**5.18.3.4 Class 4 Air.** Class 4 air shall not be recirculated or transferred to any space or recirculated within the space of origin.

**5.18.4 Documentation.** Design documentation shall indicate the justification for classification of air from any occupancy category, airstream, or location not listed in Table 6-1, 6-2, or 6-3.

**5.19 Requirements for Buildings Containing ETS Areas and ETS-Free Areas.** The requirements of this section must be met when a building contains both ETS areas and ETS-free areas. Such buildings shall be constructed and operated in accordance with Sections 5.19.1 through 5.19.8. This section does not purport to achieve acceptable IAQ in ETS areas.

**5.19.1 Classification.** All spaces shall be classified as either ETS-free areas or ETS areas.

**5.19.2 Pressurization.** ETS-free areas shall be at a positive pressure with respect to any adjacent or connected ETS areas.

**Exceptions to 5.19.2:**

1. Dwelling units, including hotel and motel guestrooms, and adjacent properties under different ownership with separation walls that are structurally independent and that contain no openings. This exception shall apply only when
  - a. the separation walls are constructed as smoke barriers in accordance with the requirements of applicable standards;
  - b. the separation walls include an air barrier consisting of a continuous membrane or surface treatment in the separation wall that has documented resistance to air leakage—continuity of the barrier shall be maintained at openings for pipes, ducts, and other conduits and at points where the barrier meets the outside walls and other barriers; and
  - c. interior corridors common to ETS and ETS-free areas are mechanically supplied with outdoor air at the rate of 0.1 cfm/ft<sup>2</sup> (0.5 L/s·m<sup>2</sup>).
2. Adjacent spaces otherwise required to be held at negative pressure and posted with signs due to the presence of hazardous or flammable materials or vapors.

**Informative Note:** Examples of methods for demonstrating relative pressure include engineering analysis, pressure differential measurement, and airflow measurement.

**5.19.3 Separation.** Solid walls, floors, ceilings, and doors equipped with automatic closing mechanisms shall separate ETS areas from ETS-free areas.

**Exception to 5.19.3:** Openings without doors are permitted in the separation where engineered systems are designed to provide airflow from ETS-free areas into ETS areas, notwithstanding eddies that may occur in the immediate vicinity of the boundary between the ETS and ETS-free areas and reverse flow that may occur due to short-term conditions such as wind gusts.

**Informative Note:** Examples of methods for demonstrating air motion are engineering analysis and the use of a directional airflow indicator at representative locations in the opening, such as on 1 ft (0.3 m) centers or at locations required for duct traverses in standard testing and balancing procedures, such as those described in [ASHRAE Standard 111](#).

**5.19.4 Transfer Air.** When air is transferred from ETS-free areas to ETS areas, the transfer airflow rate shall be maintained regardless of whether operable doors or windows between ETS-free and ETS areas are opened or closed. Acceptable means of doing so include fixed openings in doors, walls, or floors, transfer grilles, transfer ducts, or unducted air plenums with air pressure differentials in compliance with Section 5.19.2.

**5.19.5 Recirculation.** Air-handling and natural ventilation systems shall not recirculate or transfer air from an ETS area to an ETS-free area.

**5.19.6 Exhaust Systems.** Exhaust or relief air from an ETS area shall be discharged such that none of the air is recirculated back into any ETS-free area.



**5.19.7 Signage.** A sign shall be posted outside each entrance to each ETS area. The sign shall state, as a minimum, “This Area May Contain Environmental Tobacco Smoke” in letters at least 1 in. (25 mm) high or otherwise in compliance with accessibility guidelines.

**Exception to 5.19.7:** Instead of the specified sign, equivalent notification means acceptable to the AHJ may be used.

**Informative Note:** Based on the definition of “ETS area,” such a sign might be posted outside a larger ETS area that includes the area where smoking is permitted.

**5.19.8 Reclassification.** An area that was previously an ETS area but now meets the requirements of an ETS-free area shall be permitted to be classified as such where smoke exposure has stopped and odor and irritation from residual ETS contaminants are not apparent.

## 6. PROCEDURES

**6.1 General.** The Ventilation Rate Procedure, the IAQ Procedure, the Natural Ventilation Procedure, or a combination thereof shall be used to meet the requirements of this section. In addition, the requirements for exhaust ventilation in Section 6.5 shall be met regardless of the method used to determine minimum outdoor airflow rates.

**Informative Note:** Although the intake airflow determined using each of these approaches may differ significantly because of assumptions about the design, any of these approaches is a valid basis for design.

**6.1.1 Ventilation Rate Procedure.** The prescriptive design procedure presented in Section 6.2, in which outdoor air intake rates are determined based on space type/application, occupancy level, and floor area, shall be permitted to be used for any zone or system.

**6.1.2 Indoor Air Quality (IAQ) Procedure.** The performance-based design procedure presented in Section 6.3, in which the building outdoor air intake rates and other system design parameters are based on an analysis of contaminant sources, contaminant concentration limits, and level of perceived indoor air acceptability, shall be permitted to be used for any zone or system.

**6.1.3 Natural Ventilation Procedure.** The prescriptive or engineered system design procedure presented in Section 6.4, in which outdoor air is provided through openings to the outdoors, shall be permitted to be used for any zone or portion of a zone in conjunction with mechanical ventilation systems in accordance with Section 6.4.

**6.1.4 Outdoor Air Treatment.** Each ventilation system that provides outdoor air shall comply with Sections 6.1.4.1 through 6.1.4.4.

**Exception to 6.1.4:** Systems supplying air for enclosed parking garages, warehouses, storage rooms, janitor’s closets, trash rooms, recycling areas, shipping/receiving/distribution areas.

**Informative Note:** Occupied spaces ventilated with outdoor air that is judged to be unacceptable are subject to reduced air quality when outdoor air is not cleaned prior to introduction to the occupied spaces.

**6.1.4.1 Particulate Matter Smaller than 10 Micrometers (PM10).** In buildings located in an area where the national standard or guideline for PM10 is exceeded, particle filters or air-cleaning devices shall be provided to clean the outdoor air at any location prior to its introduction to occupied spaces. Particulate matter filters or air cleaners shall have either

- a. a MERV of not less than 8 where rated in accordance with [ASHRAE Standard 52.2](#) or
- b. the minimum efficiency within ISO ePM10 where rated in accordance with ISO 16890.

**Informative Note:** See Informative [Appendix D](#) for resources regarding selected PM10 national standards and guidelines.

**6.1.4.2 Particulate Matter Smaller than 2.5 Micrometers (PM2.5).** In buildings located in an area where the national standard or guideline for PM2.5 is exceeded, particle filters or air-cleaning devices shall be provided to clean the outdoor air at any location prior to its introduction to occupied spaces. Particulate matter filters or air cleaners shall have either

- a. a MERV of not less than 11 where rated in accordance with [ASHRAE Standard 52.2](#) or
- b. the minimum efficiency within ISO ePM2.5 where rated in accordance with ISO 16890.

**Informative Note:** See Informative [Appendix D](#) for resources regarding selected PM2.5 national standards and guidelines.

**6.1.4.3 Ozone.** Air-cleaning devices for ozone shall be provided when the most recent three-year average annual fourth-highest daily maximum eight-hour average ozone concentration exceeds 0.100 ppm (195 µg/m<sup>3</sup>).

Such air-cleaning devices shall have a volumetric ozone removal efficiency of not less than 40% where installed, operated, and maintained in accordance with manufacturer recommendations and shall be approved by the authority having jurisdiction (AHJ). Such devices shall be operated where the outdoor ozone levels are expected to exceed 0.100 ppm (195 µg/m<sup>3</sup>).

**Exceptions to 6.1.4.3:** Air cleaning for ozone shall not be required where

1. the system design outdoor air intake flow is 1.5 ach or less,
2. controls are provided that sense outdoor ozone level and reduce intake airflow to 1.5 ach or less while complying with the outdoor airflow requirements of Section 6, or
3. outdoor air is brought into the building and heated by direct-fired makeup air units.

**Informative Note:** In the U.S., a most recent three-year average annual fourth-highest daily maximum eight-hour average ozone concentration exceeding 0.100 ppm (195 µg/m<sup>3</sup>) equates to a USEPA eight-hour ozone classification of “Serious” or higher (Severe 15, Severe 17, or Extreme).

**6.1.4.4 Other Outdoor Contaminants.** In buildings located in an area where the national standard for one or more contaminants not addressed in Section 6.1.4 is exceeded, any design assumptions and calculations related to the impact on IAQ shall be included in the design documents.

**6.2 Ventilation Rate Procedure.** The outdoor air intake flow ( $V_{ol}$ ) for a ventilation system shall be determined in accordance with Section 6.1.4 and Sections 6.2.1 through 6.2.6.

**Informative Note:** Additional explanation of terms used below is contained in Normative Appendix A, along with a ventilation system schematic (Figure A-1).

**6.2.1 Zone Calculations.** Ventilation zone parameters shall be determined in accordance with Sections 6.2.1.1 through 6.2.1.3 for ventilation zones served by the ventilation system, except that the ventilation rates from ASHRAE/ASHRAE Standard 170 shall be used for the occupancy categories within the scope of ASHRAE/ASHRAE Standard 170.

**Informative Note:** The ventilation rates in ASHRAE/ASHRAE Standard 170 are intended to achieve aseptis and control odor migration and might not be adequate to achieve acceptable IAQ as defined in Standard 62.1.

**6.2.1.1 Breathing Zone Outdoor Airflow.** The outdoor airflow required in the breathing zone ( $V_{bz}$ ) of the occupiable space or spaces in a ventilation zone shall be not less than the value determined in accordance with Equation 6-1.

$$V_{bz} = R_p \times P_z + R_a \times A_z \tag{6-1}$$

where

$A_z$  = zone floor area, the net occupiable floor area of the ventilation zone, ft<sup>2</sup> (m<sup>2</sup>)

$P_z$  = zone population, the number of people in the ventilation zone during use

$R_p$  = outdoor airflow rate required per person as determined from Table 6-1

**Informative Note:** These values are based on adapted occupants.

$R_a$  = outdoor airflow rate required per unit area as determined from Table 6-1

**Informative Notes:**

1. Equation 6-1 accounts for people-related sources and area-related sources independently in the determination of the outdoor air rate required at the breathing zone. The use of Equation 6-1 in the context of this standard does not necessarily imply that simple addition of outdoor airflow rates for different sources can be applied to any other aspect of IAQ.
2. The rates in Table 6-1 are based on all other applicable requirements of this standard being met. If other requirements of the standard are not met, then the rates do not apply.

**6.2.1.1.1 Unlisted Occupancy.** Where the occupancy category for a proposed space or zone is not listed, the requirements for the listed occupancy category that is most similar in terms of occupant density, activities, and building construction shall be used.

**Table 6-1 Minimum Ventilation Rates in Breathing Zone**

Occupancy Category	People Outdoor Air Rate $R_p$		Area Outdoor Air Rate $R_a$		Default Values		Air Class	OS (6.2.6.1.4)
	cfm/person	L/s·person	cfm/ft <sup>2</sup>	L/s·m <sup>2</sup>	Occupant Density			
					#/1000 ft <sup>2</sup>	or #/100 m <sup>2</sup>		
<b>Animal Facilities</b>								
Animal exam room (veterinary office)	10	5	0.12	0.6	20		2	
Animal imaging (MRI/CT/PET)	10	5	0.18	0.9	20		3	
Animal operating rooms	10	5	0.18	0.9	20		3	
Animal postoperative recovery room	10	5	0.18	0.9	20		3	
Animal preparation rooms	10	5	0.18	0.9	20		3	
Animal procedure room	10	5	0.18	0.9	20		3	
Animal surgery scrub	10	5	0.18	0.9	20		3	
Large-animal holding room	10	5	0.18	0.9	20		3	
Necropsy	10	5	0.18	0.9	20		3	
Small-animal-cage room (static cages)	10	5	0.18	0.9	20		3	
Small-animal-cage room (ventilated cages)	10	5	0.18	0.9	20		3	
<b>Correctional Facilities</b>								
Booking/waiting	7.5	3.8	0.06	0.3	50		2	
Cell	5	2.5	0.12	0.6	25		2	
Dayroom	5	2.5	0.06	0.3	30		1	
Guard stations	5	2.5	0.06	0.3	15		1	
<b>Educational Facilities</b>								
Art classroom	10	5	0.18	0.9	20		2	
Classrooms (ages 5 to 8)	10	5	0.12	0.6	25		1	
Classrooms (age 9 plus)	10	5	0.12	0.6	35		1	
Computer lab	10	5	0.12	0.6	25		1	
Daycare sickroom	10	5	0.18	0.9	25		3	
Daycare (through age 4)	10	5	0.18	0.9	25		2	
Lecture classroom	7.5	3.8	0.06	0.3	65		1	✓
Lecture hall (fixed seats)	7.5	3.8	0.06	0.3	150		1	✓
Libraries	5	2.5	0.12	0.6	10			
Media center	10	5	0.12	0.6	25		1	
Multiuse assembly	7.5	3.8	0.06	0.3	100		1	✓
Music/theater/dance	10	5	0.06	0.3	35		1	✓
Science laboratories	10	5	0.18	0.9	25		2	

a. Outpatient facilities to which the rates apply are freestanding birth centers, urgent care centers, neighborhood clinics and physicians offices, Class 1 imaging facilities, outpatient psychiatric facilities, outpatient rehabilitation facilities, and outpatient dental facilities.

b. The requirements of this table provide for acceptable IAQ. The requirements of this table do not address the airborne transmission of airborne viruses, bacteria, and other infectious contagions.

**Informative Note:** These rates are intended only for outpatient dental clinics where the amount of nitrous oxide is limited. They are not intended for dental operatories in institutional buildings where nitrous oxide is piped.

**Table 6-1 Minimum Ventilation Rates in Breathing Zone (Continued)**

Occupancy Category	People Outdoor Air Rate $R_p$		Area Outdoor Air Rate $R_a$		Default Values	Air Class	OS (6.2.6.1.4)
	cfm/person	L/s·person	cfm/ft <sup>2</sup>	L/s·m <sup>2</sup>	Occupant Density		
					#/1000 ft <sup>2</sup> or #/100 m <sup>2</sup>		
<b>Educational Facilities (continued)</b>							
University/college laboratories	10	5	0.18	0.9	25	2	
Wood/metal shop	10	5	0.18	0.9	20	2	
<b>Food and Beverage Service</b>							
Bars, cocktail lounges	7.5	3.8	0.18	0.9	100	2	
Cafeteria/fast-food dining	7.5	3.8	0.18	0.9	100	2	
Kitchen (cooking)	7.5	3.8	0.12	0.6	20	2	
Restaurant dining rooms	7.5	3.8	0.18	0.9	70	2	
<b>Food and Beverage Service, General</b>							
Break rooms	5	2.5	0.06	0.3	25	1	✓
Coffee stations	5	2.5	0.06	0.3	20	1	✓
Conference/meeting	5	2.5	0.06	0.3	50	1	✓
Corridors	—	—	0.06	0.3	—	1	✓
Occupiable storage rooms for liquids or gels	5	2.5	0.12	0.6	2	2	
<b>Hotels, Motels, Resorts, Dormitories</b>							
Barracks sleeping areas	5	2.5	0.06	0.3	20	1	✓
Bedroom/living room	5	2.5	0.06	0.3	10	1	✓
Laundry rooms, central	5	2.5	0.12	0.6	10	2	
Laundry rooms within dwelling units	5	2.5	0.12	0.6	10	1	
Lobbies/prefunction	7.5	3.8	0.06	0.3	30	1	✓
Multipurpose assembly	5	2.5	0.06	0.3	120	1	✓
<b>Miscellaneous Spaces</b>							
Banks or bank lobbies	7.5	3.8	0.06	0.3	15	1	✓
Bank vaults/safe deposit	5	2.5	0.06	0.3	5	2	✓
Computer (not printing)	5	2.5	0.06	0.3	4	1	✓
Freezer and refrigerated spaces (<50°F [10°C])	10	5	0	0	0	2	
Manufacturing where hazardous materials are not used	10	5.0	0.18	0.9	7	2	
Manufacturing where hazardous materials are used (excludes heavy industrial and chemical processes)	10	5.0	0.18	0.9	7	3	
Pharmacy (prep. area)	5	2.5	0.18	0.9	10	2	
Photo studios	5	2.5	0.12	0.6	10	1	
Shipping/receiving	10	5	0.12	0.6	2	2	

a. Outpatient facilities to which the rates apply are freestanding birth centers, urgent care centers, neighborhood clinics and physicians offices, Class 1 imaging facilities, outpatient psychiatric facilities, outpatient rehabilitation facilities, and outpatient dental facilities.

b. The requirements of this table provide for acceptable IAQ. The requirements of this table do not address the airborne transmission of airborne viruses, bacteria, and other infectious contagions.

**Informative Note:** These rates are intended only for outpatient dental clinics where the amount of nitrous oxide is limited. They are not intended for dental operatories in institutional buildings where nitrous oxide is piped.

**Table 6-1 Minimum Ventilation Rates in Breathing Zone (Continued)**

Occupancy Category	People Outdoor Air Rate $R_p$		Area Outdoor Air Rate $R_a$		Default Values		Air Class	OS (6.2.6.1.4)
	cfm/person	L/s·person	cfm/ft <sup>2</sup>	L/s·m <sup>2</sup>	Occupant Density			
					#/1000 ft <sup>2</sup>	or #/100 m <sup>2</sup>		
<b>Miscellaneous Spaces (continued)</b>								
Sorting, packing, light assembly	7.5	3.8	0.12	0.6	7		2	
Telephone closets	—	—	0.00	0.0	—		1	
Transportation waiting	7.5	3.8	0.06	0.3	100		1	✓
Warehouses	10	5	0.06	0.3	—		2	
<b>Office Buildings</b>								
Breakrooms	5	2.5	0.12	0.6	50		1	
Main entry lobbies	5	2.5	0.06	0.3	10		1	✓
Occupiable storage rooms for dry materials	5	2.5	0.06	0.3	2		1	
Office space	5	2.5	0.06	0.3	5		1	✓
Reception areas	5	2.5	0.06	0.3	30		1	✓
Telephone/data entry	5	2.5	0.06	0.3	60		1	✓
<b>Outpatient Health Care Facilities <sup>a,b</sup></b>								
Birthing room	10	5	0.18	0.9	15		2	
Class 1 imaging rooms	5	2.5	0.12	0.6	5		1	
Dental operatory	10	5	0.18	0.9	20		1	
General examination room	7.5	3.8	0.12	0.6	20		1	
Other dental treatment areas	5	2.5	0.06	0.3	5		1	
Physical therapy exercise area	20	10	0.18	0.9	7		2	
Physical therapy individual room	10	5	0.06	0.3	20		1	
Physical therapeutic pool area	—	—	0.48	2.4	—		2	
Prosthetics and orthotics room	10	5	0.18	0.9	20		1	
Psychiatric consultation room	5	2.5	0.06	0.3	20		1	
Psychiatric examination room	5	2.5	0.06	0.3	20		1	
Psychiatric group room	5	2.5	0.06	0.3	50		1	
Psychiatric seclusion room	10	5	0.06	0.3	5		1	
Speech therapy room	5	2.5	0.06	0.3	20		1	
Urgent care examination room	7.5	3.8	0.12	0.6	20		1	
Urgent care observation room	5	2.5	0.06	0.3	20		1	
Urgent care treatment room	7.5	3.8	0.18	0.9	20		1	
Urgent care triage room	10	5	0.18	0.9	20		1	

a. Outpatient facilities to which the rates apply are freestanding birth centers, urgent care centers, neighborhood clinics and physicians offices, Class 1 imaging facilities, outpatient psychiatric facilities, outpatient rehabilitation facilities, and outpatient dental facilities.

b. The requirements of this table provide for acceptable IAQ. The requirements of this table do not address the airborne transmission of airborne viruses, bacteria, and other infectious contagions.

**Informative Note:** These rates are intended only for outpatient dental clinics where the amount of nitrous oxide is limited. They are not intended for dental operatories in institutional buildings where nitrous oxide is piped.

**Table 6-1 Minimum Ventilation Rates in Breathing Zone (Continued)**

Occupancy Category	People Outdoor Air Rate $R_p$		Area Outdoor Air Rate $R_a$		Default Values	Air Class	OS (6.2.6.1.4)
	cfm/person	L/s·person	cfm/ft <sup>2</sup>	L/s·m <sup>2</sup>	Occupant Density		
					#/1000 ft <sup>2</sup> or #/100 m <sup>2</sup>		
<b>Public Assembly Spaces</b>							
Auditorium seating area	5	2.5	0.06	0.3	150	1	✓
Courtrooms	5	2.5	0.06	0.3	70	1	✓
Legislative chambers	5	2.5	0.06	0.3	50	1	✓
Libraries	5	2.5	0.12	0.6	10	1	
Lobbies	5	2.5	0.06	0.3	150	1	✓
Museums (children's)	7.5	3.8	0.12	0.6	40	1	
Museums/galleries	7.5	3.8	0.06	0.3	40	1	✓
Places of religious worship	5	2.5	0.06	0.3	120	1	✓
<b>Retail</b>							
Sales (except as below)	7.5	3.8	0.12	0.6	15	2	
Barbershop	7.5	3.8	0.06	0.3	25	2	✓
Beauty and nail salons	20	10	0.12	0.6	25	2	
Coin-operated laundries	7.5	3.8	0.12	0.6	20	2	
Mall common areas	7.5	3.8	0.06	0.3	40	1	✓
Pet shops (animal areas)	7.5	3.8	0.18	0.9	10	2	
Supermarket	7.5	3.8	0.06	0.3	8	1	✓
<b>Sports and Entertainment</b>							
Bowling alley (seating)	10	5	0.12	0.6	40	1	
Disco/dance floors	20	10	0.06	0.3	100	2	✓
Gambling casinos	7.5	3.8	0.18	0.9	120	1	
Game arcades	7.5	3.8	0.18	0.9	20	1	
Gym, sports arena (play area)	20	10	0.18	0.9	7	2	
Health club/aerobics room	20	10	0.06	0.3	40	2	
Health club/weight rooms	20	10	0.06	0.3	10	2	
Spectator areas	7.5	3.8	0.06	0.3	150	1	✓
Stages, studios	10	5	0.06	0.3	70	1	✓
Swimming (pool and deck)	—	—	0.48	2.4	—	2	
<b>Transient Residential</b>							
Common corridors	—	—	0.06	0.3		1	✓
Dwelling unit	5	2.5	0.06	0.3	F	1	✓

- a. Outpatient facilities to which the rates apply are freestanding birth centers, urgent care centers, neighborhood clinics and physicians offices, Class 1 imaging facilities, outpatient psychiatric facilities, outpatient rehabilitation facilities, and outpatient dental facilities.
- b. The requirements of this table provide for acceptable IAQ. The requirements of this table do not address the airborne transmission of airborne viruses, bacteria, and other infectious contagions.

**Informative Note:** These rates are intended only for outpatient dental clinics where the amount of nitrous oxide is limited. They are not intended for dental operatories in institutional buildings where nitrous oxide is piped.

**Table 6-2 Minimum Exhaust Rates**

Occupancy Category	Exhaust Rate, cfm/unit	Exhaust Rate, cfm/ft <sup>2</sup>	Notes	Exhaust Rate, L/s-unit	Exhaust Rate, L/s-m <sup>2</sup>	Air Class
<b>Animal Facilities</b>						
Animal imaging (MRI/CT/PET)	—	0.90		—	4.5	3
Animal operating rooms	—	3.00		—	15	3
Animal postoperative recovery room	—	1.50		—	7.5	3
Animal preparation rooms	—	1.50		—	7.5	3
Animal procedure room	—	2.25		—	11.3	3
Animal surgery scrub	—	1.50		—	7.5	3
Large-animal holding room	—	2.25		—	11.3	3
Necropsy	—	2.25		—	11.3	3
Small-animal-cage room (static cages)	—	2.25		—	11.3	3
Small-animal-cage room (ventilated cages)	—	1.50		—	7.5	3
Arenas	—	0.50	B	—	—	1
Art classrooms	—	0.70		—	3.5	2
Auto repair rooms	—	1.50	A	—	7.5	2
Barber shops	—	0.50		—	2.5	2
Beauty and nail salons	—	0.60		—	3.0	2
Cells with toilet	—	1.00		—	5.0	2
Copy, printing rooms	—	0.50		—	2.5	2
Darkrooms	—	1.00		—	5.0	2
Educational science laboratories	—	1.00		—	5.0	2
Janitor closets, trash rooms, recycling	—	1.00		—	5.0	3
Kitchenettes	—	0.30		—	1.5	2
Kitchens—commercial	—	0.70		—	3.5	2
Locker rooms for athletic, industrial, and health care facilities	—	0.50		—	2.5	2
All other locker rooms	—	0.25	—	—	1.25	2
Shower rooms	20/50		G,I	10/25		2
Paint spray booths	—	—	F	—	—	4
Parking garages	—	0.75	C	—	3.7	2
Pet shops (animal areas)	—	0.90	—	—	4.5	2
Refrigerating machinery rooms	—	—	F	—	—	3
Residential kitchens	50/100	—	G	25/50	—	2
Soiled laundry storage rooms	—	1.00	F	—	5.0	3
Storage rooms, chemical	—	1.50	F	—	7.5	4
Toilets—private	25/50	—	E, H	12.5/25	—	2
Toilets—public	50/70	—	D, H	25/35	—	2
Woodwork shop/classrooms	—	0.50	—	—	2.5	2

**NOTES:**

- A Stands where engines are run shall have exhaust systems that directly connect to the engine exhaust and prevent escape of fumes.
- B Where combustion equipment is intended to be used on the playing surface, additional dilution ventilation, source control, or both shall be provided.
- C Exhaust shall not be required where two or more sides compose walls that are at least 50% open to the outside.
- D Rate is per water closet, urinal, or both. Provide the higher rate where periods of heavy use are expected to occur. The lower rate shall be permitted to be used otherwise.
- E Rate is for a toilet room intended to be occupied by one person at a time. For continuous system operation during hours of use, the lower rate shall be permitted to be used. Otherwise the higher rate shall be used.
- F See other applicable standards for exhaust rate.
- G For continuous system operation, the lower rate shall be permitted to be used. Otherwise the higher rate shall be used.
- H Exhaust air that has been cleaned to meet Class 1 criteria from Section 5.18.1 shall be permitted to be recirculated.
- I Rate is per showerhead.



**Table 6-3 Airstreams or Sources**

Description	Air Class
Commercial kitchen grease hoods	4
Commercial kitchen hoods other than grease	3
Diazo printing equipment discharge	4
Hydraulic elevator machine room	2
Laboratory hoods	4
Paint spray booths	4
Refrigerating machinery rooms	3
Residential kitchen hoods in transient occupancy	3

**6.2.1.1.2 Source Strengths.** The Ventilation Rate Procedure minimum rates are based on contaminant sources and source strengths that are typical for the listed occupancy categories. Where unusual sources are expected, the additional ventilation or air cleaning required shall be calculated using Section 6.3.6 of the IAQ Procedure or criteria established by the EHS professional responsible to the owner.

**Informative Notes:**

1. Zones where emissions are expected from stored hazardous materials are not typical for any listed occupancy category.
2. Dry ice, theatrical smoke, and smoke-producing activities are not typical for any listed occupancy categories.

**6.2.1.1.3 Air Density.** Volumetric airflow rates are based on dry-air density of 0.075 lb<sub>da</sub>/ft<sup>3</sup> (1.2 kg<sub>da</sub>/m<sup>3</sup>) at a barometric pressure of 1 atm (101.3 kPa) and an air temperature of 70°F (21°C). Rates shall be permitted to be adjusted for actual density.

**6.2.1.1.4 Dwelling Units with Transient Occupancy.** Air from one residential dwelling shall not be recirculated or transferred to any other space outside of that dwelling.

**6.2.1.1.5 Laboratories.** Laboratory spaces that comply with all requirements of ANSI/AIHA Z9.5 are not required to comply with the rates in Table 6-1.

**6.2.1.1.6 Animal Facilities.** Animal facilities that have completed a risk evaluation performed by the environmental health and safety professional responsible to the owner or to the owner’s designee are not required to comply with the rates in Table 6-1.

**6.2.1.1.7 Design Zone Population.** Design zone population ( $P_z$ ) shall equal the largest (peak) number of people expected to occupy the ventilation zone during typical use.

**Exceptions to 6.2.1.1.7:**

1. Where the number of people expected to occupy the ventilation zone fluctuates, zone population equal to the average number of people shall be permitted, provided such average is determined in accordance with Section 6.2.5.2.
2. Where the largest or average number of people expected to occupy the ventilation zone cannot be established for a specific design, an estimated value for zone population shall be permitted, provided such value is the product of the net occupiable area of the ventilation zone and the default occupant density listed in Table 6-1.

**6.2.1.1.7.1 Design Zone Population for Dwelling Units with Transient Occupancy.** Default occupancy for dwelling units shall be two persons for studio and one-bedroom units, with one additional person for each additional bedroom.

**6.2.1.2 Zone Air Distribution Effectiveness.** The zone air distribution effectiveness ( $E_z$ ) shall be determined in accordance with Table 6-4 or Normative Appendix C.

**Informative Notes:**

1. For some configurations, the default value depends on space and supply air temperature.
2. Calculation of  $E_z$  using the procedures in Normative Appendix C may result in values greater than those listed in Table 6-4 for systems with the same description.



**Table 6-4 Zone Air Distribution Effectiveness**

Air Distribution Configuration	$E_z$
<b>Well-Mixed Air Distribution Systems</b>	
Ceiling supply of cool air	1.0
Ceiling supply of warm air and floor return	1.0
Ceiling supply of warm air 15°F (8°C) or more above space temperature and ceiling return	0.8
Ceiling supply of warm air less than 15°F (8°C) above average space temperature where the supply air-jet velocity is less than 150 fpm (0.8 m/s) within 4.5 ft (1.4 m) of the floor and ceiling return	0.8
Ceiling supply of warm air less than 15°F (8°C) above average space temperature where the supply air-jet velocity is equal to or greater than 150 fpm (0.8 m/s) within 4.5 ft (1.4 m) of the floor and ceiling return	1.0
Floor supply of warm air and floor return	1.0
Floor supply of warm air and ceiling return	0.7
Makeup supply outlet located more than half the length of the space from the exhaust, return, or both	0.8
Makeup supply outlet located less than half the length of the space from the exhaust, return, or both	0.5
<b>Stratified Air Distribution Systems (Section 6.2.1.2.1)</b>	
Floor supply of cool air where the vertical throw is greater than or equal to 60 fpm (0.25 m/s) at a height of 4.5 ft (1.4 m) above the floor and ceiling return at a height less than or equal to 18 ft (5.5 m) above the floor	1.05
Floor supply of cool air where the vertical throw is less than or equal to 60 fpm (0.25 m/s) at a height of 4.5 ft (1.4 m) above the floor and ceiling return at a height less than or equal to 18 ft (5.5 m) above the floor	1.2
Floor supply of cool air where the vertical throw is less than or equal to 60 fpm (0.25 m/s) at a height of 4.5 ft (1.4 m) above the floor and ceiling return at a height greater than 18 ft (5.5 m) above the floor	1.5
<b>Personalized Ventilation Systems (Section 6.2.1.2.2)</b>	
Personalized air at a height of 4.5 ft (1.4 m) above the floor combined with ceiling supply of cool air and ceiling return	1.40
Personalized air at a height of 4.5 ft (1.4 m) above the floor combined with ceiling supply of warm air and ceiling return	1.40
Personalized air at a height of 4.5 ft (1.4 m) above the floor combined with a stratified air distribution system with nonaspirating floor supply devices and ceiling return	1.20
Personalized air at a height of 4.5 ft (1.4 m) above the floor combined with a stratified air distribution system with aspirating floor supply devices and ceiling return	1.50

**6.2.1.2.1 Stratified Air Distribution Systems.** A stratified air distribution system shall be designed in accordance with the following subsections, or the zone air distribution effectiveness ( $E_z$ ) shall be determined in accordance with Normative Appendix C.

**6.2.1.2.1.1 Supply Air.** Cool air shall be at least 4°F (2°C) less than the average room air temperature.

**6.2.1.2.1.2 Return Air.** The return air openings or pathways shall be located more than 9 ft (2.8 m) above the floor.

**6.2.1.2.1.3 Stratification.** The zone shall not contain any devices that mechanically mix the air, and shall be protected from impinging airstreams from adjacent ventilation zones.

**Informative Note:** Ceiling fans, blowers, air curtains, aspirating diffusers without adequate draft separation, or other devices that disrupt the stratification cause the zone air distribution effectiveness to be similar to a well-mixed system.

**6.2.1.2.2 Personalized Ventilation Systems.** A personalized ventilation system shall be designed in accordance with the following subsections, or the zone air distribution effectiveness ( $E_z$ ) shall be determined in accordance with Normative Appendix C.

**Informative Note:** A personalized ventilation system is primarily for exposure control and dilution of contaminants in the breathing zone and may provide some spot cooling. Personalized ventilation is used when the occupant spends most of their time in one occupied space.

The ventilation outlet is usually incorporated into or mounted on the furniture. It is used in conjunction with another air distribution system that handles the area ventilation requirements and thermal loads in the space.

**6.2.1.2.2.1 Personalized Air.** The personalized air shall be distributed in the breathing zone and designed such that the velocity is equal to or less than 50 fpm (0.25 m/s) at the head/facial region of the occupant.

**6.2.1.2.2.2 Return Air.** The return air openings or pathways shall be located more than 9 ft (2.8 m) above the floor.

**6.2.1.3 Zone Outdoor Airflow.** The zone outdoor airflow ( $V_{oz}$ ) provided to the ventilation zone by the supply air distribution system shall be determined in accordance with Equation 6-2.

$$V_{oz} = V_{bz}/E_z \quad (6-2)$$

**6.2.2 Single-Zone Systems.** For ventilation systems wherein one or more air handler supplies a mixture of outdoor air and recirculated air to only one ventilation zone, the outdoor air intake flow ( $V_{ot}$ ) shall be determined in accordance with Equation 6-3.

$$V_{ot} = V_{oz} \quad (6-3)$$

**6.2.3 100% Outdoor Air Systems.** For ventilation systems wherein one or more air handler supplies only outdoor air to one or more ventilation zones, the outdoor air intake flow ( $V_{ot}$ ) shall be determined in accordance with Equation 6-4.

$$V_{ot} = \sum_{all\ zones} V_{oz} \quad (6-4)$$

**6.2.4 Multiple-Zone Recirculating Systems.** For ventilation systems wherein one or more air handler supplies a mixture of outdoor air and recirculated air to more than one ventilation zone, the outdoor air intake flow ( $V_{ot}$ ) shall be determined in accordance with Sections 6.2.4.1 through 6.2.4.4.

**6.2.4.1 Uncorrected Outdoor Air Intake.** The uncorrected outdoor air intake ( $V_{ou}$ ) flow shall be determined in accordance with Equation 6-5.

$$V_{ou} = D \sum_{all\ zones} (R_p \times P_z) + \sum_{all\ zones} (R_a \times A_z) \quad (6-5)$$

**6.2.4.1.1 Occupant Diversity.** The occupant diversity ratio ( $D$ ) shall be determined in accordance with Equation 6-6 to account for variations in population within the ventilation zones served by the system.

$$D = P_s / \sum_{all\ zones} P_z \quad (6-6)$$

where the system population ( $P_s$ ) is the total population in the area served by the system.

**Exception to 6.2.4.1.1:** Alternative methods to account for occupant diversity shall be permitted, provided the resulting  $V_{ou}$  value is not less than that determined using Equation 6-5.

**6.2.4.1.2 Design System Population.** Design system population ( $P_s$ ) shall equal the largest (peak) number of people expected to occupy all ventilation zones served by the ventilation system during use.

**Informative Note:** Design system population is always equal to or less than the sum of design zone population for all zones in the area served by the system because all zones may not be simultaneously occupied at design population.

**6.2.4.1.3 Other Ventilation Requirements.** When a zone ventilation rate is obtained from criteria other than this standard, the ventilation rate shall be converted to cfm or L/s and the value added to  $V_{ou}$  for use in system design calculations.

**6.2.4.2 System Ventilation Efficiency.** The system ventilation efficiency ( $E_v$ ) shall be determined in accordance with Section 6.2.4.3 for the Simplified Procedure or Normative Appendix A for the Alternative Procedure.

**Informative Note:** These procedures also establish zone minimum primary airflow rates for VAV systems.

### 6.2.4.3 Simplified Procedure

**6.2.4.3.1 System Ventilation Efficiency.** System ventilation efficiency ( $E_v$ ) shall be determined in accordance with Equation 6-7 or 6-8.

$$E_v = 0.88 \times D + 0.22 \text{ for } D < 0.60 \quad (6-7)$$

$$E_v = 0.75 \text{ for } D \geq 0.60 \quad (6-8)$$

**6.2.4.3.2 Zone Minimum Primary Airflow.** For each zone, the minimum primary airflow ( $V_{pz-min}$ ) shall be determined in accordance with Equation 6-9.

$$V_{pz-min} = V_{oz} \times 1.5 \quad (6-9)$$

**6.2.4.4 Outdoor Air Intake.** The design outdoor air intake flow ( $V_{ot}$ ) shall be determined in accordance with Equation 6-10.

$$V_{ot} = V_{ot}/E_v \quad (6-10)$$

## 6.2.5 Design for Varying Operating Conditions

**6.2.5.1 Variable Load Conditions.** Ventilation systems shall be designed to be capable of providing not less than the minimum ventilation rates required in the breathing zone where the zones served by the system are occupied, including all full- and part-load conditions.

**Informative Note:** The minimum outdoor air intake flow may be less than the design value at part-load conditions.

**6.2.5.2 Short-Term Conditions.** Where it is known that peak occupancy will be of short duration, ventilation will be varied or interrupted for a short period of time, or both, the design shall be permitted to be based on the average conditions over a time period ( $T$ ) determined by Equation 6-11a (I-P) or 6-11b (SI).

$$T = 3v/V_{bz} \quad (6-11a)$$

$$T = 50v/V_{bz} \quad (6-11b)$$

where

$T$  = averaging time period, min

$v$  = the volume of the ventilation zone where averaging is being applied, ft<sup>3</sup> (m<sup>3</sup>)

$V_{bz}$  = the breathing zone outdoor airflow calculated using Equation 6-1 and the design value of the zone population ( $P_z$ ), cfm (L/s)

Acceptable design adjustments based on this optional provision include the following:

- Zones with fluctuating occupancy: The zone population ( $P_z$ ) shall be permitted to be averaged over time ( $T$ ).
- Zones with intermittent interruption of supply air: The average outdoor airflow supplied to the breathing zone over time ( $T$ ) shall be not less than the breathing zone outdoor airflow ( $V_{bz}$ ) calculated using Equation 6-1.
- Systems with intermittent closure of the outdoor air intake: The average outdoor air intake over time ( $T$ ) shall be not less than the minimum outdoor air intake ( $V_{ot}$ ) calculated using Equation 6-3, 6-4, or 6-5 as appropriate.

**6.2.6 Dynamic Reset.** The system shall be permitted to be designed to reset the outdoor air intake flow ( $V_{ot}$ ), the space or ventilation zone airflow ( $V_{oz}$ ) as operating conditions change, or both.

**6.2.6.1 Demand Control Ventilation (DCV).** DCV shall be permitted as an optional means of dynamic reset.

**Exception to 6.2.6.1:** CO<sub>2</sub>-based DCV shall not be applied in zones with indoor sources of CO<sub>2</sub> other than occupants, or with CO<sub>2</sub> removal mechanisms, such as gaseous air cleaners.

**6.2.6.1.1** For DCV zones in the occupied mode, breathing zone outdoor airflow ( $V_{bz}$ ) shall be reset in response to current population. Current population estimates used in DCV control calculations shall not result in ventilation rates that are less than those required by the actual population during any one-hour time period.

**6.2.6.1.2** For DCV zones in the occupied mode, breathing zone outdoor airflow ( $V_{bz}$ ) shall be not less than the building component ( $R_a \times A_z$ ) for the zone.

**6.2.6.1.3** Where CO<sub>2</sub> sensors are used for DCV, the CO<sub>2</sub> sensors shall be certified by the manufacturer to be accurate within  $\pm 75$  ppm at concentrations of both 600 and 1000 ppm when

measured at sea level at 77°F (25°C). Sensors shall be factory calibrated and certified by the manufacturer to require calibration not more frequently than once every five years. Upon detection of sensor failure, the system shall provide a signal that resets the ventilation system to supply the required minimum quantity of outdoor air ( $V_{bz}$ ) to the breathing zone for the design zone population ( $P_z$ ).

**6.2.6.1.4** For DCV zones in the occupied standby mode, breathing zone outdoor airflow shall be permitted to be reduced to zero for the occupancy categories indicated “OS” in Table 6-1, provided that airflow is restored to  $V_{bz}$  whenever occupancy is detected.

**6.2.6.1.5 Documentation.** A written description of the equipment, methods, control sequences, set points, and the intended operational functions shall be provided. A table shall be provided that shows the minimum and maximum outdoor intake airflow for each system.

**6.2.6.2 Ventilation Efficiency.** Variations in the efficiency with which outdoor air is distributed to the occupants under different ventilation system airflows and temperatures shall be permitted as an optional basis of dynamic reset.

**6.2.6.3 Outdoor Air Fraction.** A higher fraction of outdoor air in the air supply due to intake of additional outdoor air for free cooling or exhaust air makeup shall be permitted as an optional basis of dynamic reset.

**6.3 Indoor Air Quality (IAQ) Procedure.** Breathing zone outdoor airflow ( $V_{bz}$ ) shall be determined in accordance with Sections 6.3.1 through 6.3.5.

**6.3.1 Contaminant Sources.** Each contaminant of concern, for purposes of the design, shall be identified. For each contaminant of concern, indoor sources and outdoor sources shall be identified, and the emission rate for each contaminant of concern from each source shall be determined. Where two or more contaminants of concern target the same organ system, these contaminants shall be considered to be a contaminant mixture.

**6.3.2 Contaminant Concentration.** For each contaminant of concern, a concentration limit and its corresponding exposure period and an appropriate reference to a cognizant authority shall be specified. For each contaminant mixture of concern, the ratio of the concentration of each contaminant to its concentration limit shall be determined, and the sum of these ratios shall be not greater than one.

**Exception to 6.3.2:** Consideration of odors in determining concentration limits shall not be required.

**Informative Note:** Odors are addressed in Section 6.3.4.2.

**6.3.3 Perceived Indoor Air Quality.** The design level of indoor air acceptability shall be specified in terms of the percentage of building occupants, visitors, or both expressing satisfaction with perceived IAQ.

**6.3.4 Design Approach.** Zone and system outdoor airflow rates shall be the larger of those determined in accordance with Section 6.3.4.1 and either Section 6.3.4.2 or 6.3.4.3, based on emission rates, concentration limits, and other relevant design parameters.

**6.3.4.1 Mass Balance Analysis.** Using a steady-state or dynamic mass-balance analysis, the minimum outdoor airflow rates required to achieve the concentration limits specified in Section 6.3.2 shall be determined for each contaminant or contaminant mixture of concern within each zone served by the system.

**Informative Notes:**

1. Informative Appendix E includes steady-state mass-balance equations that describe the impact of air cleaning on outdoor air and recirculation rates for ventilation systems serving a single zone.
2. In the completed building, measurement of the concentration of contaminants or contaminant mixtures of concern may be useful as a means of checking the accuracy of the design mass-balance analysis, but such measurement is not required for compliance.

**6.3.4.2 Subjective Evaluation.** Using a subjective occupant evaluation conducted in the completed building, the minimum outdoor airflow rates required to achieve the level of acceptability specified in Section 6.3.3 shall be determined within each zone served by the system.

**Informative Note:** Level of acceptability often increases in response to increased outdoor airflow rates, increased level of indoor or outdoor air cleaning, or decreased indoor or outdoor contaminant emission rate.

**6.3.4.3 Similar Zone.** The minimum outdoor airflow rates shall be not less than those found in accordance with Section 6.3.4.2 for a substantially similar zone.

**6.3.5 Combined IAQ Procedure and Ventilation Rate Procedure.** The IAQ Procedure in conjunction with the Ventilation Rate Procedure shall be permitted to be applied to a zone or system. In this case, the Ventilation Rate Procedure shall be used to determine the required zone minimum outdoor airflow, and the IAQ Procedure shall be used to determine the additional outdoor air or air cleaning necessary to achieve the concentration limits of the contaminants and contaminant mixtures of concern.

**Informative Note:** The improvement of IAQ through the use of air cleaning or provision of additional outdoor air in conjunction with minimum ventilation rates may be quantified using the IAQ Procedure.

**6.3.6 Documentation.** Where the IAQ Procedure is used, the following information shall be included in the design documentation: the contaminants and contaminant mixtures of concern considered in the design process, the sources and emission rates of the contaminants of concern, the concentration limits and exposure periods and the references for these limits, and the analytical approach used to determine ventilation rates and air-cleaning requirements. The contaminant monitoring and occupant or visitor evaluation plans shall also be included in the documentation.

**6.4 Natural Ventilation Procedure.** Natural ventilation systems shall comply with the requirements of either Section 6.4.1 or 6.4.2. Designers shall provide interior air barriers, insulation, or other means that separate naturally ventilated spaces from mechanically cooled spaces to prevent high-dew-point outdoor air from coming into contact with mechanically cooled surfaces.

**6.4.1 Prescriptive Compliance Path.** Any zone designed for natural ventilation shall include a mechanical ventilation system designed in accordance with Section 6.2, Section 6.3, or both.

**Exceptions to 6.4.1:**

1. Zones in buildings that have all of the following:
  - a. Natural ventilation openings that comply with the requirements of Section 6.4.1.
  - b. Controls that prevent the natural ventilation openings from being closed during periods of expected occupancy, or natural ventilation openings that are permanently open.
2. Zones that are not served by heating or cooling equipment.

**6.4.1.1 Ceiling Height.** For ceilings that are parallel to the floor, the ceiling height ( $H$ ) to be used in Sections 6.4.1.3 through 6.4.1.5 shall be the minimum ceiling height in the zone.

For zones wherein ceiling height increases as distance from the ventilation increases, the ceiling height shall be the average height of the ceiling determined over a distance not greater than 6 m (20 ft) from the openings.

**6.4.1.2 Floor Area to be Ventilated.** The naturally ventilated area in zones or portions of zones shall extend from the openings to a distance determined by Sections 6.4.1.3, 6.4.1.4, or 6.4.1.5. Openings shall meet the requirements of Section 6.4.1.6. For zones where ceilings are not parallel to the floor, the ceiling height shall be determined in accordance with Section 6.4.1.1.

**6.4.1.3 Single Side Opening.** For zones with openings on only one side of the zone, the naturally ventilated area shall extend to a distance not greater than two times the height of the ceiling from the openings.

**6.4.1.4 Double Side Opening.** For zones with openings on two opposite sides of the zone, the naturally ventilated area shall extend between the openings separated by a distance not greater than five times the height of the ceiling.

**6.4.1.5 Corner Openings.** For zones with openings on two adjacent sides of a zone, the naturally ventilated area shall extend to a distance not greater than five times the height of the ceiling along a line drawn between the outside edges of the two openings that are the farthest

apart. Floor area outside that line shall comply with Section 6.4.1.3 as a zone having openings on only one side of the zone.

**Informative Note:** *Floor area outside that line* refers to the remaining area of the zone that is not bounded by the walls that have the openings and the line drawn between the openings.

**6.4.1.6 Location and Size of Openings.** Zones or portions of zones to be naturally ventilated shall have a permanently open airflow path to openings directly connected to the outdoors. The minimum flow rate to the zone shall be determined in accordance with Section 6.2.1.1. This flow rate shall be used to determine the required openable area of openings, accounting only for buoyancy-driven flow. Wind-driven flow shall be used only where it can be demonstrated that the minimum flow rate is provided during all occupied hours. Openings shall be sized in accordance with Section 6.4.1.6.1 (Path A) or Section 6.4.1.6.2 (Path B).

**Informative Note:** *Permanently open airflow path* refers to pathways that would allow airflow unimpeded by partitions, walls, furnishings, etc.

**6.4.1.6.1 Sizing Openings—Path A.** Where the zone is ventilated using a single opening or multiple single openings located at the same elevation, the openable area as a percent of the net occupiable floor area shall be greater than or equal to the value indicated in Table 6-5. Where the zone is ventilated using two openings located at different elevations or multiple pairs of such openings, the openable area as a percent of the net occupiable floor area shall be greater than or equal to the value indicated in Table 6-6.

Where openings are obstructed by louvers or screens, the openable area shall be based on the net free area of the opening. Where interior zones, or portions of zones, without direct openings to the outdoors are ventilated through adjoining zones, the opening between zones shall be permanently unobstructed and have a free area of not less than twice the percent of occupiable floor area used to determine the opening size of adjacent exterior zones, or 25 ft<sup>2</sup> (2.3 m<sup>2</sup>), whichever is greater.

**Informative Note:** Tables 6-5 and 6-6 are based solely on buoyancy-driven flow and have not been created to address thermal comfort.

**6.4.1.6.2 Sizing Openings—Path B.** The required openable area for a single zone shall be calculated using CIBSE AM10, Section 4.3.

**6.4.2 Engineered System Compliance Path.** For an engineered natural ventilation system, the designer shall

- a. determine hourly environmental conditions, including outdoor air dry-bulb temperature; dew-point temperature; outdoor concentration of contaminants, including PM2.5, PM10, and ozone where data are available; wind speed and direction; and internal heat gains during expected hours of natural ventilation operation.
- b. determine the effect of pressure losses along natural ventilation airflow paths on the resulting flow rates, including inlet openings, air transfer grills, ventilation stacks, and outlet openings during representative conditions of expected natural ventilation system use.
- c. quantify natural ventilation airflow rates of identified airflow paths accounting for wind induced and thermally induced driving pressures during representative conditions of expected natural ventilation system use.
- d. design to provide outdoor air in quantities sufficient to result in acceptable IAQ as established under Section 6.2.1.1 or 6.3 during representative conditions of expected natural ventilation system use.

**6.4.3 Control and Accessibility.** The means to open required openings shall be readily accessible to building occupants whenever the space is occupied. Controls shall be designed to coordinate operation of the natural and mechanical ventilation systems.

**6.4.4 Documentation.** Where the Natural Ventilation Procedure is used, the designer shall document the values and calculations that demonstrate conformance with the compliance path and the controls systems and sequences required for operation of the natural ventilation system, including coordination with mechanical ventilation systems. Where the Prescriptive Compliance Path is used for buildings located in an area where the national standard for one or more contaminants is exceeded, any design assumptions and calculations related to the impact on IAQ shall be included in the design documents.



**Table 6-5 Minimum Openable Areas: Single Openings<sup>a</sup>**

$V_{bz}/A_z \leq$ ( $l/s/m^2$ )	$V_{bz}/A_z \leq$ ( $cfm/ft^2$ )	Total Openable Areas in Zone as a Percentage of $A_z$		
		$H_S/W_S \leq 0.1$	$0.1 < H_S/W_S \leq 1$	$H_S/W_S > 1$
1.0	0.2	4.0	2.9	2.5
2.0	0.4	6.9	5.0	4.4
3.0	0.6	9.5	6.9	6.0
4.0	0.8	12.0	8.7	7.6
5.5	1.1	15.5	11.2	9.8

where

$V_{bz}$  = breathing zone outdoor airflow, per Table 6-1.

$A_z$  = zone floor area, the net occupiable floor area of the ventilation zone.

$W_S$  = aggregated width of all single outdoor openings located at the same elevation.

$H_S$  = vertical dimension of the single opening or the least vertical dimension of the openings where there are multiple openings.

a. Volumetric airflow rates used to estimate required openable area are based on the following:

- Dry-air density of 0.075 lbda/ft<sup>3</sup> (1.2 kgda/m<sup>3</sup>) at a barometric pressure of 1 atm (101.3 kPa) and an air temperature of 70°F (21°C)
- Temperature difference between indoors and outdoors of 1.8°F (1°C)
- Gravity constant of 32.2 ft/s<sup>2</sup> (9.81 m/s<sup>2</sup>)
- Window discharge coefficient of 0.6

**Table 6-6 Minimum Openable Areas: Two Vertically Spaced Openings<sup>a</sup>**

$V_{bz}/A_z \leq$ ( $l/s/m^2$ )	$V_{bz}/A_z \leq$ ( $cfm/ft^2$ )	Total Openable Areas in Zone as a Percentage of $A_z$					
		$H_{vs} \leq 8.2 \text{ ft (2.5 m)}$		$8.2 \text{ ft (2.5m)} < H_{vs} \leq 16.4 \text{ ft (5 m)}$		$16.4 \text{ ft (5 m)} < H_{vs}$	
		$A_s/A_l \leq 0.5$	$A_s/A_l > 0.5$	$A_s/A_l \leq 0.5$	$A_s/A_l > 0.5$	$A_s/A_l \leq 0.5$	$A_s/A_l > 0.5$
1.0	0.2	2.0	1.3	1.3	0.8	0.9	0.6
2.0	0.4	4.0	2.6	2.5	1.6	1.8	1.2
3.0	0.6	6.0	3.9	3.8	2.5	2.7	1.7
4.0	0.8	8.0	5.2	5.0	3.3	3.6	2.3
5.5	1.1	11.0	7.1	6.9	4.5	4.9	3.2

where

$V_{bz}$  = breathing zone outdoor airflow, per Table 6-1.

$A_z$  = zone floor area, the net occupiable floor area of the ventilation zone.

$H_{vs}$  = vertical separation between the center of the top and bottom openings' free operable area; in case of multiple horizontally spaced pairs of openings, use shortest distance encountered.

$A_s$  = openable area of smallest opening (top or bottom); in case of multiple horizontally spaced pairs of top-and-bottom openings, use aggregated areas.

$A_l$  = openable area of largest opening (top or bottom); in case of multiple horizontally spaced pairs of top-and-bottom openings, use aggregated areas.

a. Volumetric airflow rates used to estimate required operable area are based on the following:

- Dry-air density of 0.075 lbda/ft<sup>3</sup> (1.2 kgda/m<sup>3</sup>) at a barometric pressure of 1 atm (101.3 kPa) and an air temperature of 70°F (21°C)
- Temperature difference between indoors and outdoors of 1.8°F (1°C)
- Gravity constant of 32.2 ft/s<sup>2</sup> (9.81 m/s<sup>2</sup>)
- Window discharge coefficient of 0.6

**6.5 Exhaust Ventilation.** The Prescriptive Compliance Path or the Performance Compliance Path shall be used to meet the requirements of this section. Exhaust makeup air shall be permitted to be any combination of outdoor air, recirculated air, or transfer air.

**6.5.1 Prescriptive Compliance Path.** The design exhaust airflow shall be determined in accordance with the requirements in Tables 6-2 and 6-3.

**Exception to 6.5.1:** Laboratory spaces that comply with all requirements of ANSI/AIHA Z9.5.

**6.5.1.1 Laboratory Hoods.** Exhaust from laboratory hoods shall be Air Class 4 unless determined otherwise by the Environmental Health and Safety professional responsible to the owner or to the owner's designee.

**6.5.1.2 Pressure Requirements.** While the required exhaust systems are operating, the exhaust airflow of zones listed in Table 6-2 shall be larger than their respective supply airflow.

If zones listed in Table 6-2 are adjacent, the difference between the exhaust and the supply airflow shall be larger for the zone with the higher number class of air.

**Exception to 6.5.1.2:** Where airflow offset requirements are established by the Environmental Health and Safety professional responsible to the owner or owner’s designee.

**Informative Notes:**

1. Exhaust systems are required for any occupancy category listed in Table 6-2.
2. Where intermittent operation is allowed in Table 6-2, exhaust equipment is intended to be operated when the space is in use.

**6.5.2 Performance Compliance Path.** The exhaust airflow shall be determined in accordance with the following subsections.

**6.5.2.1 Contaminant Sources.** Contaminants or mixtures of concern for purposes of the design shall be identified. For each contaminant or mixture of concern, indoor sources (occupants, materials, activities, and processes) and outdoor sources shall be identified, and the emission rate for each contaminant of concern from each source shall be determined.

**6.5.2.2 Contaminant Concentration.** For each contaminant of concern, a concentration limit and its corresponding exposure period and an appropriate reference to a cognizant authority shall be specified.

**6.5.2.3** Monitoring and control systems shall be provided to automatically detect contaminant levels of concern and modulate exhaust airflow such that contaminant levels are maintained at not greater than the specified contaminant concentration limits.

**6.6 Design Documentation Procedures.** Design criteria and assumptions shall be documented and made available for operation of the system after installation. See Sections 4.3, 5.1.3, 5.18.4, 6.2.6.1.5, 6.3.6, and 6.4.4 regarding assumptions to be detailed in the documentation.

## 7. CONSTRUCTION AND SYSTEM START-UP

### 7.1 Construction Phase

**7.1.1 Application.** The requirements of this section apply to ventilation systems and the spaces they serve in new buildings and additions to or alterations in existing buildings.

**7.1.2 Filters.** Systems designed with particle filters shall not be operated without filters in place.

**7.1.3 Protection of Materials.** When recommended by the manufacturer, building materials shall be protected from rain and other sources of moisture by appropriate in-transit and on-site procedures. Porous materials with visible microbial growth shall not be installed. Nonporous materials with visible microbial growth shall be decontaminated.

#### 7.1.4 Protection of Occupied Areas

**7.1.4.1 Application.** The requirements of Section 7.1.4 apply when construction requires a building permit and entails sanding, cutting, grinding, or other activities that generate significant amounts of airborne particles or procedures that generate significant amounts of gaseous contaminants.

**7.1.4.2 Protective Measures.** Measures shall be employed to reduce the migration of construction-generated contaminants to occupied areas.

**Informative Note:** Examples of acceptable measures include, but are not limited to, sealing the construction area using temporary walls or plastic sheathing, exhausting the construction area, or pressurizing contiguous occupied areas.

**7.1.5 Air Duct System Construction.** Air duct systems shall be constructed in accordance with the following standards, as applicable:

- a. The following sections of ANSI/SMACNA 006, *HVAC Duct Construction Standards—Metal and Flexible*:
  - Section S1.9 of Section 1.3.1, “Duct Construction and Installation Standards”
  - Section 7.4, “Installation Standards for Rectangular Ducts Using Flexible Liner”
  - Section 3.5, “Duct Installation Standards”
  - Section 3.6, “Specification for Joining and Attaching Flexible Duct”
  - Section 3.7, “Specification for Supporting Flexible Duct”



- Sections S6.1, S6.3, S6.4, and S6.5 of Section 9.1, “Casing and Plenum Construction Standards”
- b. All sections of SMACNA’s *Fibrous Glass Duct Construction Standards*
- c. NFPA 90A, *Standard for the Installation of Air-Conditioning and Ventilating Systems*
- d. NFPA 90B, *Standard for the Installation of Warm Air Heating and Air-Conditioning Systems*

## 7.2 System Start-Up

**7.2.1 Application.** The requirements of this section apply to the following ventilation systems:

- a. Newly installed air-handling systems
- b. Existing air-handling systems undergoing supply air or outdoor airflow reduction (Only the requirements of Section 7.2.2 shall apply to these altered systems.)
- c. Existing air-handling distribution systems undergoing alterations affecting more than 25% of the floor area served by the systems (Only the requirements of Section 7.2.2 shall apply to these altered systems.)

**7.2.2 Air Balancing and Verification of Outdoor Air Performance.** Ventilation systems shall be balanced in accordance with [ASHRAE Standard 111](#) or another applicable national standards so as to verify conformance with the total outdoor airflow requirements of this standard ( $V_{ot}$ ).

**7.2.3 Testing of Drain Pans.** To minimize conditions of water stagnation that may result in microbial growth, drain pans shall be field tested under operating conditions that are the most restrictive to condensate flow to demonstrate proper drainage.

**Exception to 7.2.3:** Field testing of drain pans is not required if units with factory-installed drain pans have been certified (attested in writing) by the manufacturer for proper drainage when installed as recommended.

**Informative Note:** Above conditions usually occur at full fan airflow for draw-through fans and minimum fan airflow for blow-through fans.

**7.2.4 Ventilation System Start-Up.** Ventilation air distribution systems shall be clean of dirt and debris.

**7.2.5 Outdoor Air Dampers.** Prior to occupancy, each ventilation system shall be tested to demonstrate that outdoor air dampers operate in accordance with the system design.

**7.2.6 Documentation.** The following ventilation system documentation shall be provided to the building owner or his/her designee, retained within the building, and made available to the building operating personnel:

- a. An operations and maintenance manual describing basic data relating to the operation and maintenance of ventilation systems and equipment as installed
- b. HVAC controls information consisting of diagrams, schematics, control sequence narratives, and maintenance and/or calibration information
- c. An air balance report documenting the work performed for Section 7.2.2
- d. Construction drawings of record, control drawings, and final design drawings
- e. Design criteria and assumptions

## 8. OPERATIONS AND MAINTENANCE

### 8.1 General

**8.1.1 Application.** The requirements of this section apply to buildings and their ventilation systems and their components constructed or renovated after the adoption date of this section.

**8.1.2 Building Alterations or Change of Use.** When buildings are altered or when changes in building use, occupant category, significant change in occupant density, or other changes inconsistent with system design assumptions are made, the ventilation system design, operation, and maintenance shall be reevaluated and the operations and maintenance (O&M) manual updated as necessary.

**8.2 O&M Manual.** An O&M manual, either written or electronic, shall be developed and maintained on site or in a centrally accessible location for the working life of the applicable ventilation system equipment or components. This manual shall be updated as necessary. The

**Table 8-1 Minimum Maintenance Activity and Frequency for Ventilation System Equipment and Associated Components**

Inspection/Maintenance Task	Frequency <sup>a</sup>
a. Investigate system for water intrusion or accumulation. Rectify as necessary.	As necessary
b. Verify that the space provided for routine maintenance and inspection of open cooling tower water systems, closed cooling tower water systems, and evaporative condensers is unobstructed.	Monthly
c. Open cooling tower water systems, closed cooling tower water systems, and evaporative condensers shall be treated to limit the growth of microbiological contaminants, including <i>legionella sp.</i>	Monthly
d. Verify that the space provided for routine maintenance and inspection of equipment and components is unobstructed.	Quarterly
e. Check pressure drop and scheduled replacement date of filters and air-cleaning devices. Clean or replace as necessary to ensure proper operation.	Quarterly
f. Check ultraviolet lamp. Clean or replace as needed to ensure proper operation.	Quarterly
g. Visually inspect dehumidification and humidification devices. Clean and maintain to limit fouling and microbial growth. Measure relative humidity and adjust system controls as necessary.	Quarterly
h. Maintain floor drains and trap primer located in air plenums or rooms that serve as air plenums to prevent transport of contaminants from the floor drain to the plenum.	Semiannually
i. Check ventilation and IAQ related control systems and devices for proper operation. Clean, lubricate, repair, adjust, or replace as needed to ensure proper operation.	Semiannually
j. Check P-traps in floor drains located in plenums or rooms that serve as air plenums. Prime as needed to ensure proper operation.	Semiannually
k. Check fan belt tension. Check for belt wear and replace if necessary to ensure proper operation. Check sheaves for evidence of improper alignment or evidence of wear and correct as needed.	Semiannually
l. Check variable-frequency drive for proper operation. Correct as needed.	Semiannually
m. Check for proper operation of cooling or heating coil for damage or evidence of leaks. Clean, restore, or replace as required.	Semiannually
n. Visually inspect outdoor air intake louvers, bird screens, mist eliminators, and adjacent areas for cleanliness and integrity; clean as needed; remove all visible debris or visible biological material observed and repair physical damage to louvers, screens, or mist eliminators if such damage impairs the item from providing the required outdoor air entry.	Semiannually
o. Visually inspect natural ventilation openings and adjacent areas for cleanliness and integrity; clean as needed. Remove all visible debris or visible biological material observed and repair physical damage to louvers, and screens if such damage impairs the item from providing the required outdoor air entry. Manual and/or automatic opening apparatus shall be physically tested for proper operation and repaired or replaced as necessary.	Semiannually
p. Verify the operation of the outdoor air ventilation system and any dynamic minimum outdoor air controls.	Annually
q. Check air filter fit and housing seal integrity. Correct as needed.	Annually
r. Check control box for dirt, debris, and/or loose terminations. Clean and tighten as needed.	Annually
s. Check motor contactor for pitting or other signs of damage. Repair or replace as needed.	Annually
t. Check fan blades and fan housing. Clean, repair, or replace as needed to ensure proper operation.	Annually
u. Check integrity of all panels on equipment. Replace fasteners as needed to ensure proper integrity and fit/finish of equipment.	Annually
v. Assess field serviceable bearings. Lubricate if necessary.	Annually
w. Check drain pans, drain lines, and coils for biological growth. Check adjacent areas for evidence of unintended wetting. Repair and clean as needed.	Annually
x. Check for evidence of buildup or fouling on heat exchange surfaces. Restore as needed to ensure proper operation.	Annually
y. Inspect unit for evidence of moisture carryover from cooling coils beyond the drain pan. Make corrections or repairs as necessary.	Annually
z. Check for proper damper operation. Clean, lubricate, repair, replace, or adjust as needed to ensure proper operation.	Annually
aa. Visually inspect areas of moisture accumulation for biological growth. If present, clean or disinfect as needed.	Annually

a. Minimum frequencies may be increased or decreased if indicated in the O&M manual.

**Table 8-1 Minimum Maintenance Activity and Frequency for Ventilation System Equipment and Associated Components (Continued)**

Inspection/Maintenance Task	Frequency <sup>a</sup>
ab. Check condensate pump. Clean or replace as needed.	Annually
ac. Visually inspect exposed ductwork and external piping for insulation and vapor barrier for integrity. Correct as needed.	Annually
ad. Verify the accuracy of permanently mounted sensors whose primary function is outdoor air delivery monitoring, outdoor air delivery verification, or dynamic minimum outdoor air control, such as flow stations at an air handler and those used for demand control ventilation, including CO <sub>2</sub> sensors. A sensor failing to meet the accuracy specified in the O&M manual shall be recalibrated or replaced. Performance verification shall include output comparison to a measurement reference standard consistent with those specified for similar devices in <i>ASHRAE Standard 41.2</i> or <i>ASHRAE Standard 111</i> .	5 years
ae. Verify the total quantity of outdoor air delivered by air handlers set to minimum outdoor air mode. If measured minimum airflow rates are less than the design minimum rate documented in the O&M manual, ± a 10% balancing tolerance, (1) confirm the measured rate does not conform with the provisions of this standard and (2) adjust or modify the air-handler components to correct the airflow deficiency. Ventilation systems shall be balanced in accordance with <i>ASHRAE Standard 111</i> or its equivalent, at least to the extent necessary to verify conformance with the total outdoor airflow and space supply airflow requirements of this standard.	5 years
<b>Exception:</b> Units under 2000 cfm (1000 L/s) of supply air are exempt from this requirement.	

a. Minimum frequencies may be increased or decreased if indicated in the O&M manual.

manual shall include the O&M procedures, ventilation system operating schedules and any changes made thereto, final design drawings, maintenance schedules based on manufacturer instructions, and the maintenance requirements and frequencies provided in Table 8-1.

**8.3 Ventilation System Operation.** Mechanical and natural ventilation systems shall be operated in a manner consistent with the O&M manual. Systems shall be operated such that spaces are ventilated in accordance with Section 6 during periods of expected occupancy.

**8.4 Ventilation System Maintenance.** The building ventilation system components shall be maintained in accordance with the O&M manual.

## 9. NORMATIVE REFERENCES

Reference	Title	Section
<b>Air Movement and Control Association International, Inc. (AMCA)</b> <b>30 West University Drive</b> <b>Arlington Heights, IL 60004-1893, United States</b> <b>1-847-394-0150; www.amca.org</b>		
AMCA 500-L-15	Laboratory Methods of Testing Louvers for Rating	5.5.2
<b>American Industrial Hygiene Association (AIHA)</b> <b>3141 Fairview Park Drive, Suite 777</b> <b>Falls Church, VA 22042, United States</b> <b>(703) 849-8888; www.aiha.org</b>		
ANSI/AIHA Z9.5-2012	Standard for Laboratory Ventilation	5.5.1.4; 6.2.1.1.5; 6.5.1; B1.1
<b>ASHRAE</b> <b>1791 Tullie Circle NE</b> <b>Atlanta, GA 30329, United States</b> <b>1-404-636-8400; www.ashrae.org</b>		
ANSI/ASHRAE Standard 41.2 (2018)	Standard Methods for Air Velocity and Airflow Measurement	Table 8-1
ANSI/ASHRAE Standard 52.2 (2017)	Method of Testing General Ventilation Air-Cleaning Devices for Removal Efficiency by Particle Size	5.9; 6.1.4.1; 6.1.4.2
ANSI/ASHRAE Standard 111-2008 (RA 2017)	Measurement, Testing, Adjusting, and Balancing of Building HVAC Systems	7.2.2; Table 8-1
ANSI/ASHRAE/ASHE Standard 170 (2017)	Ventilation for Health Care Facilities	6.2.2
<b>ASTM International</b> <b>100 Barr Harbor Dr.</b> <b>West Conshohocken, PA 19428-2959, United States</b> <b>1-610-832-9585; www.astm.org</b>		
ASTM D3273 (2016)	Standard Test Method for Resistance to Growth of Mold on the Surface of Interior Coatings in an Environmental Chamber	5.4.1
ASTM C1338 (2014)	Standard Test Method for Determining Fungi Resistance of Insulation Materials and Facings	5.4.1
<b>Chartered Institution of Building Services Engineers (CIBSE)</b> <b>222 Balham High Road</b> <b>London</b> <b>SW12 9BS</b> <b>United Kingdom</b> <b>+44 (0)20 8675 5211; www.cibse.org</b>		
CIBSE AM10 (2005)	Natural Ventilation in Non-Domestic Buildings	6.4.1.6.2
<b>International Organization for Standardization (ISO)</b> <b>ISO Central Secretariat, 1 rue de Varembee, Case postale 56</b> <b>CH-1211 Geneva 20, Switzerland</b> <b>+41-22-749-01-11; www.iso.org</b>		
ISO 16890 (2016)	Air Filters for General Ventilation	5.9; 6.1.4.1; 6.1.4.2
<b>National Fire Protection Association (NFPA)</b> <b>1 Battery March Park</b> <b>Quincy, MA 02169-7471</b> <b>United States</b> <b>1-617-770-0700; www.nfpa.org</b>		
ANSI Z223.1/NFPA-54 (2018)	National Fuel Gas Code	5.5.1.2
NFPA-31 (2016)	Standard for the Installation of Oil-Burning Equipment	5.5.1.2

Reference	Title	Section
NFPA-45 (2015)	Standard on Fire Protection for Laboratories Using Chemicals	B1.1
NFPA-90A (2018)	Standard for the Installation of Air-Conditioning and Ventilating Systems	7.1.5
NFPA-90B (2018)	Standard for the Installation of Warm Air Heating and Air-Conditioning Systems	7.1.5
NFPA-211 (2019)	Standard for Chimneys, Fireplaces, Vents, and Solid Fuel-Burning Appliances	5.5.1.2
<b>NSF International</b> <b>789 Dixboro Road</b> <b>Ann Arbor, MI 48105, United States</b> <b>734-769-8010; www.nsf.org; info@nsf.org</b>		
NSF/ANSI 60 (2016)	Drinking Water Treatment Chemicals—Health Effects	5.14.1
<b>Sheet Metal and Air Conditioning Contractors National Association (SMACNA)</b> <b>4201 Lafayette Center Drive</b> <b>Chantilly, VA 20151, United States</b> <b>1-703-803-2980</b>		
	Fibrous Glass Duct Construction Standards, 7th Edition (2003)	7.1.5
ANSI/SMACNA 006 (2006)	HVAC Duct Construction Standards—Metal and Flexible, 3rd Edition	7.1.5
ANSI/SMACNA 016 (2012)	HVAC Air Duct Leakage Test Manual, 2nd Edition	5.2.2
<b>Underwriters Laboratories Inc. (UL)</b> <b>333 Pfingsten Road</b> <b>Northbrook, IL 60062, United States</b> <b>847-272-8800; www.ul.com; cec.us@us.ul.com</b>		
UL 181 (2013)	Factory-Made Air Ducts and Air Connectors, 11th Edition	5.4.1; 5.4.2
UL 1995 (2015)	Heating and Cooling Equipment, 5th Edition	5.5.2; 5.5.3
UL 2998 (2016)	Environmental Claim Validation Procedure (ECVP) for Zero Ozone Emissions from Air Cleaners	5.7.1
<b>U.S. Government Printing Office (USGPO)</b> <b>732 North Capitol St. NW</b> <b>Washington, DC 20401</b> <b>202-512-1800; www.gpo.gov</b>		
21 CFR 173.310 (2018)	Secondary Direct Food Additives Permitted in Food for Human Consumption—Boiler Water Additives	5.14.1
40 CFR 50 (2018)	National Primary and Secondary Ambient Air Quality Standards	4.1.1; 6.1.4.1; 6.1.4.2

(This is a normative appendix and is part of the standard.)

## NORMATIVE APPENDIX A MULTIPLE-ZONE SYSTEM VENTILATION EFFICIENCY: ALTERNATIVE PROCEDURE

This appendix presents an alternative procedure for calculating the system ventilation efficiency ( $E_v$ ) for multiple-zone recirculating systems that must be used when Section 6.2.4.3 is not used. In this alternative procedure,  $E_v$  is equal to the lowest calculated value of the zone ventilation efficiency ( $E_{vz}$ ) (see Equation A-2).

**Informative Note:** Figure A-1 contains a ventilation system schematic depicting most of the quantities used in this appendix.

### A1. SYSTEM VENTILATION EFFICIENCY

For any multiple-zone recirculating system, the system ventilation efficiency ( $E_v$ ) shall be calculated in accordance with Sections A1.1 through A1.3.

**A1.1 Average Outdoor Air Fraction.** The average outdoor air fraction ( $X_s$ ) for the ventilation system shall be determined in accordance with Equation A-1.

$$X_s = V_{out}/V_{ps} \quad (A-1)$$

where the uncorrected outdoor air intake ( $V_{out}$ ) is found in accordance with Section 6.2.4.1, and the system primary airflow ( $V_{ps}$ ) is found at the condition analyzed.

**Informative Note:** For VAV-system design purposes,  $V_{ps}$  is the highest expected system primary airflow at the design condition analyzed. System primary airflow at design is usually less than the sum of design zone primary airflow values because primary airflow seldom peaks simultaneously in all VAV zones.

**A1.2 Zone Ventilation Efficiency.** The zone ventilation efficiency ( $E_{vz}$ ) shall be determined in accordance with Section A1.2.1 or A1.2.2.

**A1.2.1 Single Supply Systems.** For single supply systems, wherein all of the air supplied to each ventilation zone is a mixture of outdoor air and system-level recirculated air, zone ventilation efficiency ( $E_{vz}$ ) shall be determined in accordance with Equation A-2. Examples of single supply systems include constant-volume reheat, single-duct VAV, single-fan dual-duct, and multiple-zone systems.

$$E_{vz} = 1 + X_s - Z_{pz} \quad (A-2)$$

where the average outdoor air fraction for the system ( $X_s$ ) is determined in accordance with Equation A-1, and the primary outdoor air fraction for the zone ( $Z_{pz}$ ) is determined in accordance with Equation A-3.

$$Z_{pz} = V_{oz}/V_{pz} \quad (A-3)$$

For VAV systems,  $V_{pz}$  is the lowest zone primary airflow value expected at the design condition analyzed.

**A1.2.2 Secondary Recirculation Systems.** For secondary recirculation systems wherein all or part of the supply air to each ventilation zone is recirculated air (air that has not been directly mixed with outdoor air) from other zones, zone ventilation efficiency ( $E_{vz}$ ) shall be determined in accordance with Equation A-4. Examples of secondary recirculation systems include dual-fan dual-duct and fan-powered mixing-box systems and systems that include transfer fans for conference rooms.

$$E_{vz} = (F_a + X_s \times F_b - Z_{pz} \times E_p \times F_c)/F_a \quad (A-4)$$

where system air fractions  $F_a$ ,  $F_b$ , and  $F_c$  are determined in accordance with Equation A-5, A-6, and A-7, respectively.

$$F_a = E_p + (1 - E_p) \times E_r \quad (A-5)$$

$$F_b = E_p \quad (A-6)$$

$$F_c = 1 - (1 - E_z) \times (1 - E_r) \times (1 - E_p) \quad (A-7)$$

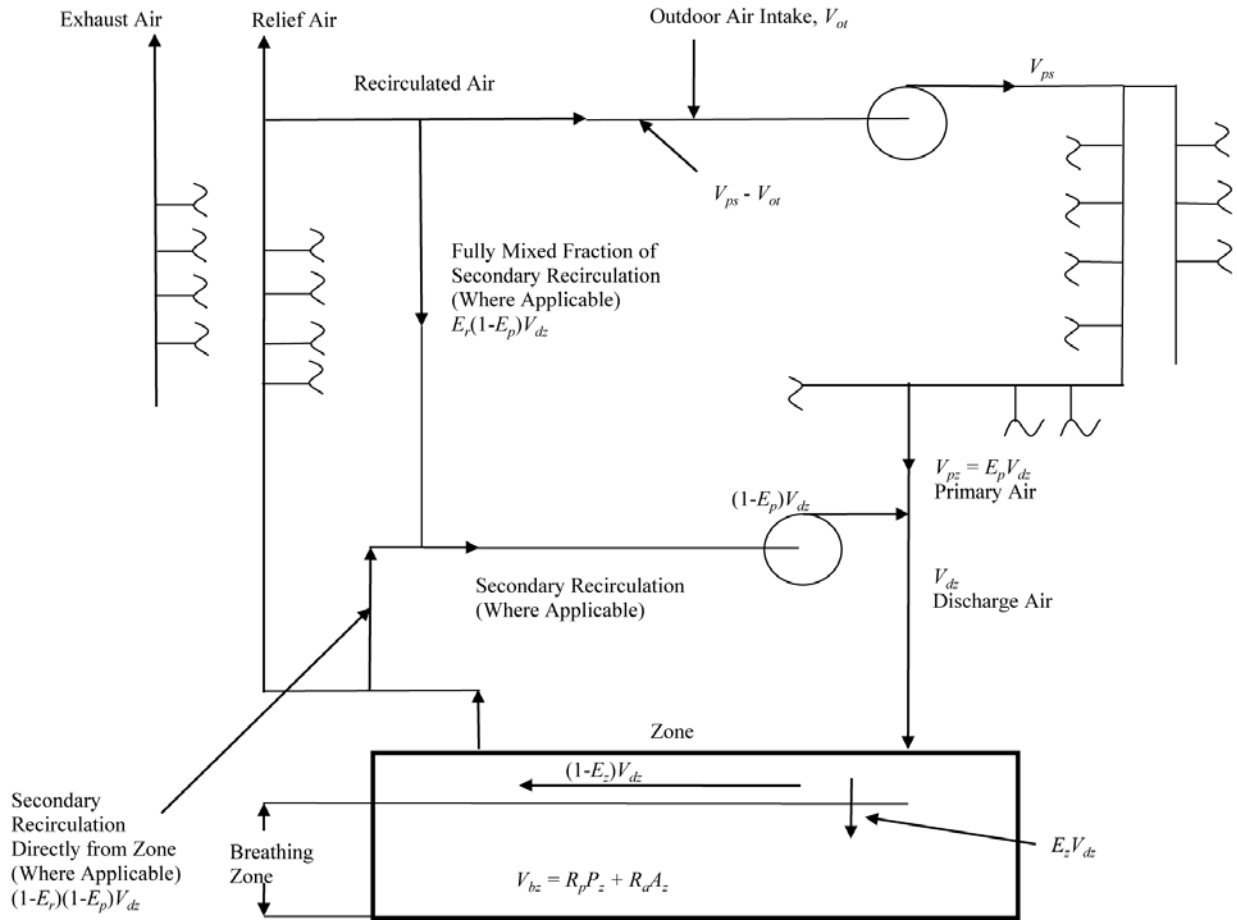

**Figure A-1 Ventilation system schematic.**

Where the zone primary air fraction ( $E_p$ ) is determined in accordance with Equation A-8, zone secondary recirculation fraction ( $E_r$ ) is determined by the designer based on system configuration, and zone air distribution effectiveness ( $E_z$ ) is determined in accordance with Section 6.2.1.2.

$$E_p = V_{pz} / V_{dz} \quad (\text{A-8})$$

where  $V_{dz}$  is zone discharge airflow.

**Informative Notes:**

1. For plenum return systems with secondary recirculation (e.g., fan-powered VAV with plenum return),  $E_r$  is usually less than 1.0, although values may range from 0.1 to 1.2 depending upon the location of the ventilation zone relative to other zones and the air handler. For ducted return systems with secondary recirculation (e.g., fan-powered VAV with ducted return),  $E_r$  is typically 0.0, while for those with system-level recirculation (e.g., dual-fan dual-duct systems with ducted return),  $E_r$  is typically 1.0. For other system types,  $E_r$  is typically 0.75.
2. For single-zone and single-supply systems,  $E_p$  is 1.0.

**A1.3 System Ventilation Efficiency.** The system ventilation efficiency shall equal the lowest zone ventilation efficiency among all ventilation zones served by the air handler in accordance with Equation A-9.

$$E_v = \text{minimum} (E_{vz}) \quad (\text{A-9})$$

**A2. DESIGN PROCESS**

The system ventilation efficiency and, therefore, the outdoor air intake flow for the system ( $V_{ot}$ ) determined as part of the design process are based on the design and minimum expected



supply airflows to individual ventilation zones as well as the design outdoor air requirements to the zones. For VAV system design purposes, zone ventilation efficiency ( $E_{vz}$ ) for each ventilation zone shall be found using the minimum expected zone primary airflow ( $V_{pz}$ ) and using the highest expected system primary airflow ( $V_{ps}$ ) at the design condition analyzed.

**Informative Note:** Increasing the zone supply airflow values during the design process, particularly to the critical zones requiring the highest fraction of outdoor air, reduces the system outdoor air intake flow requirement determined in the calculation.

**A2.1 Selecting Zones for Calculation.** Zone ventilation efficiency ( $E_{vz}$ ) shall be calculated for all ventilation zones.

**Exception to A2.1:** Because system ventilation efficiency ( $E_v$ ) is determined by the minimum value of the zone ventilation efficiency ( $E_{vz}$ ) in accordance with Equation A-9, calculation of  $E_{vz}$  is not required for any ventilation zone that has an  $E_{vz}$  value that is equal to or larger than that of the ventilation zone for which a calculation has been made.

**Informative Note:** The value of  $E_{vz}$  for a ventilation zone will be equal to or larger than that for another ventilation zone if all of the following are true relative to the other ventilation zone:

- a. Floor area per occupant ( $A_z/P_z$ ) is no lower.
- b. Minimum zone discharge airflow rate per unit area ( $V_{dz}/A_z$ ) is no lower.
- c. Primary air fraction ( $E_p$ ) is no lower.
- d. Zone air distribution effectiveness ( $E_z$ ) is no lower.
- e. Area outdoor air rate ( $R_a$ ) is no higher.
- f. People outdoor air rate ( $R_p$ ) is no higher.

### A3. SYMBOLS

- $A_z$  **zone floor area:** the net occupiable floor area of the ventilation zone, ft<sup>2</sup> (m<sup>2</sup>).
- $D$  **occupant diversity:** the ratio of the system population to the sum of the zone populations.
- $E_p$  **primary air fraction:** the fraction of primary air in the discharge air to the ventilation zone.
- $E_r$  **secondary recirculation fraction:** in systems with secondary recirculation of return air, the fraction of secondary recirculated air to the zone that is representative of average system return air rather than air directly recirculated from the zone.
- $E_v$  **system ventilation efficiency:** the efficiency with which the system distributes air from the outdoor air intake to the breathing zone in the ventilation-critical zone, which requires the largest fraction of outdoor air in the primary airstream.
- $E_{vz}$  **zone ventilation efficiency:** the efficiency with which the system distributes air from the outdoor air intake to the breathing zone in any particular ventilation zone.
- $E_z$  **zone air distribution effectiveness:** a measure of the effectiveness of supply air distribution to the breathing zone.  $E_z$  is determined in accordance with Section 6.2.1.2 or Normative Appendix C.
- $F_a$  **supply air fraction:** the fraction of supply air to the ventilation zone that includes sources of air from outside the zone.
- $F_b$  **mixed-air fraction:** the fraction of supply air to the ventilation zone from fully mixed primary air.
- $F_c$  **outdoor air fraction:** the fraction of outdoor air to the ventilation zone that includes sources of air from outside the zone.
- $P_s$  **system population:** the simultaneous number of occupants in the area served by the ventilation system.
- $P_z$  **zone population:** see Section 6.2.1.1.
- $R_a$  **area outdoor air rate:** see Section 6.2.1.1.
- $R_p$  **people outdoor air rate:** see Section 6.2.1.1.
- $V_{bz}$  **breathing zone outdoor airflow:** see Section 6.2.1.1.
- $V_{dz}$  **zone discharge airflow:** the expected discharge (supply) airflow to the zone that includes primary airflow and secondary recirculated airflow, cfm (L/s).



- $V_{ot}$  **outdoor air intake flow:** see Sections 6.2.2, 6.2.3, and 6.2.4.4.
- $V_{ou}$  **uncorrected outdoor air intake:** see Section 6.2.4.1.
- $V_{oz}$  **zone outdoor airflow:** see Section 6.2.1.3.
- $V_{ps}$  **system primary airflow:** the total primary airflow supplied to all zones served by the system from the air-handling unit at which the outdoor air intake is located.
- $V_{pz}$  **zone primary airflow:** the zone primary airflow to the ventilation zone, including outdoor air and recirculated air.
- $X_s$  **average outdoor air fraction:** at the primary air handler, the fraction of outdoor air intake flow in the system primary airflow.
- $Z_{pz}$  **primary outdoor air fraction:** the outdoor air fraction required in the primary air supplied to the ventilation zone prior to the introduction of any secondary recirculation air.

(This is a normative appendix and is part of the standard.)

## NORMATIVE APPENDIX B SEPARATION OF EXHAUST OUTLETS AND OUTDOOR AIR INTAKES

### B1. GENERAL

This appendix presents an alternative procedure for determining separation distance between outdoor air intakes and exhaust air and vent outlets. This analytical method can be used instead of Table 5-1.

Exhaust air and vent outlets, as defined in Table 5-1, shall be located no closer to outdoor air intakes, or to operable windows, skylights, and doors, both those on the subject property and those on adjacent properties, than the minimum separation distance ( $L$ ) specified in this section. The distance ( $L$ ) is defined as the shortest “stretched string” distance measured from the closest point of the outlet opening to the closest point of the outdoor air intake opening, or to the operable window, skylight, or door opening, along a trajectory as if a string were stretched between them.

**B1.1 Application.** Laboratory fume hood exhaust air outlets shall be in compliance with NFPA 45 and ANSI/AIHA Z9.5. Nonlaboratory exhaust outlets and outdoor air intakes or other openings shall be separated in accordance with the following.

**B1.2 Outdoor Air Intakes.** The minimum separation distance between exhaust air/vent outlets, as defined in Table 5-1, and outdoor air intakes to mechanical ventilation systems, or to operable windows, skylights, and doors that are required as part of natural ventilation systems, shall be equal to distance ( $L$ ) determined in accordance with Section B2.

**Exception to B1.2:** Separation distances do not apply when exhaust and outdoor air intake systems are controlled such that they cannot operate simultaneously.

**B1.3 Other Building Openings.** The minimum separation distance between building exhaust air/vent outlets, as defined in Table 5-1, and operable openings to occupiable spaces shall be half of the distance ( $L$ ) determined in accordance with Section B2. The minimum separation distance between either Class 3, Class 4, cooling tower, or combustion appliance/equipment exhaust air/vent outlets and operable openings to occupiable spaces shall be equal to the distance ( $L$ ) determined in accordance with Section B2.

**B1.4 Additional Limitations for Noxious or Dangerous Air.** The minimum separation distance between exhausts located less than 65 ft (20 m) vertically below outdoor air intakes or operable windows and doors shall be equal to a horizontal separation only as determined in accordance with Section B2; no credit may be taken for any vertical separation.

**B1.5 Equipment Wells.** Exhaust air outlets that terminate in an equipment well that also encloses an outdoor air intake shall meet the separation requirements of this section and, in addition, shall either

- a. terminate at or above the highest enclosing wall and discharge air upward at a velocity exceeding 1000 fpm (5 m/s) or
- b. terminate 3 ft (1 m) above the highest enclosing wall (with no minimum velocity).

**Exception to B1.5:** Exhaust air designated as Class 1 or Class 2.

**B1.6 Property Lines.** The minimum separation distance between exhaust air/vent outlets and property lines shall be half of the distance ( $L$ ) determined in accordance with Section B2.

**Exception to B1.6:** For Class 3, Class 4, or combustion appliance/equipment exhaust air, where the property line abuts a street or other public way, no minimum separation is required if exhaust termination is at least 10 ft (3 m) above grade.

### B2. DETERMINING DISTANCE $L$

The minimum separation distance ( $L$ ) shall be determined using one of the following three approaches:

**B2.1 Simple Method.** A value of  $L$  in Table B-1 shall be used.

**B2.2 Velocity Method.** The value of  $L$  shall be determined using Equation B-1a (I-P) or B-1b (SI).

$$L = 0.09 \times \sqrt{Q} \times (\sqrt{DF} - U/400) \text{ [ft]} \quad (\text{B-1a})$$

$$L = 0.04 \times \sqrt{Q} \times (\sqrt{DF} - U/2) \text{ [m]} \quad (\text{B-1b})$$

**Table B-1 Minimum Separation Distance**

Exhaust Air Class (See Section 5.18)	Separation Distance, L, ft (m)
Significant contaminant or odor intensity (Class 3)	15 (5)
Noxious or dangerous particles (Class 4)	30 (10)

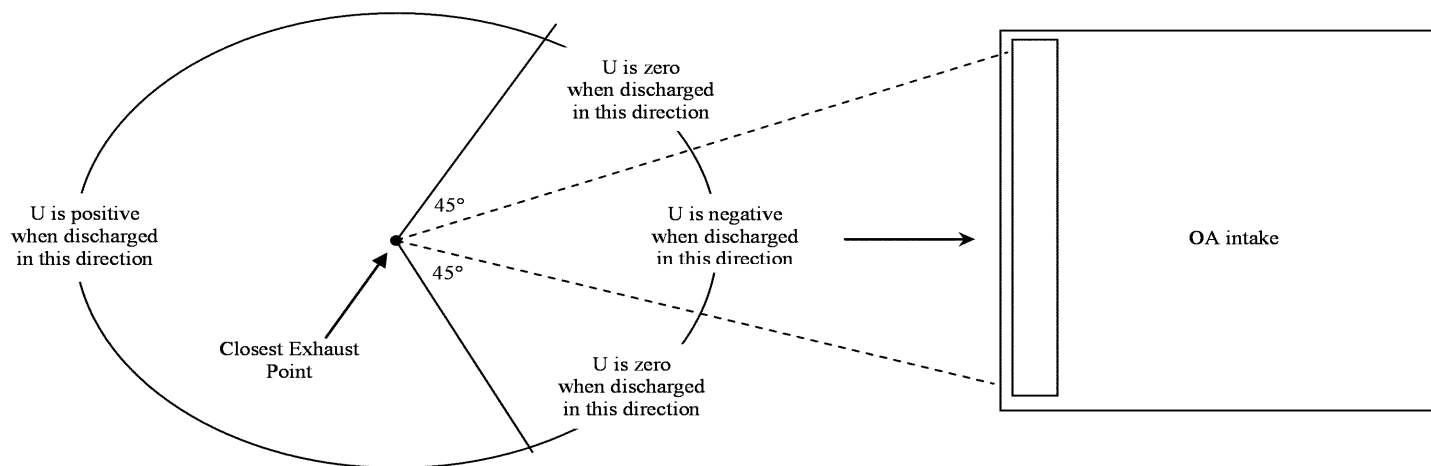

**Figure B-1 Exhaust air discharge velocity ( $U$ ).**

where

$Q$  = exhaust airflow rate, cfm (L/s). For gravity vents, such as plumbing vents, use an exhaust rate of 150 cfm (75 L/s). For flue vents from fuel-burning appliances, assume a value of 250 cfm per million Btu/h (0.43 L/s per kW) of combustion input (or obtain actual rates from the combustion appliance manufacturer).

$U$  = exhaust air discharge velocity, fpm (m/s). As shown in Figure B-1,  $U$  shall be determined using Table B-2.

$DF$  = dilution factor, which is the ratio of outdoor airflow to entrained exhaust airflow in the outdoor air intake. The minimum dilution factor shall be determined as a function of exhaust air class in Table B-3.

For exhaust air comprising more than one class of air, the dilution factor shall be determined by averaging the dilution factors by the volume fraction of each class using Equation B-3:

$$DF = \frac{\sum(DF_i \times Q_i)}{\sum Q_i} \tag{B-3}$$

where

$DF_i$  = dilution factor from Table B-2 for class  $i$  air

$Q_i$  = volumetric flow rate of class  $i$  air in the exhaust airstream

**B2.3 Concentration Method.** Determine the acceptable concentration for health ( $C_{health}$ ) and odor ( $C_{odor}$ ) for each emitted chemical, compound, or mixture.

Design the exhaust and intake systems such that the maximum concentration at the intake ( $C_{max}$ ) is less than the acceptable concentrations of all evaluated compounds and mixtures.

$$C_{max} < C_{health} \tag{B-4}$$

$$C_{max} < C_{odor} \tag{B-5}$$

At a minimum, determination of  $C_{max}$  shall consider wind speed, wind direction, exhaust exit velocity and momentum, geometry of building and adjacent structures, and architectural screens. Wind tunnel modeling is an acceptable design method.

**Table B-2 Exhaust Air Discharge Velocity**

<b>Exhaust Direction/Configuration</b>	<b>Exhaust Air Discharge Velocity (<i>U</i>) Modifier</b>
Exhaust is directed away from the outdoor air intake at an angle that is greater than 45 degrees from the direction of a line drawn from the closest exhaust point to the edge of the intake.	<i>U</i> given a positive value.
Exhaust is directed toward the intake bounded by lines drawn from the closest exhaust point to the edge of the intake.	<i>U</i> given a negative value.
Exhaust is directed at an angle between the two above cases.	<i>U</i> is zero.
Vents from gravity (atmospheric) fuel-fired appliances, plumbing vents, and other nonpowered exhausts, or if the exhaust discharge is covered by a cap or other device that dissipates the exhaust airstream.	<i>U</i> is zero.
Hot-gas exhausts such as combustion products if the exhaust stream is aimed directly upward and unimpeded by devices such as flue caps or louvers.	Add 500 fpm (2.5 m/s) upward velocity to <i>U</i> .

**Table B-3 Minimum Dilution Factors**

<b>Exhaust Air Class (See Section 5.18)</b>	<b>Dilution Factor (DF)</b>
Significant contaminant or odor intensity (Class 3)	15
Noxious or dangerous particles (Class 4)	50 <sup>a</sup>

a. Does not apply to fume hood exhaust. See Section B1.1.

(This is a normative appendix and is part of the standard.)

## NORMATIVE APPENDIX C

### ZONE AIR DISTRIBUTION EFFECTIVENESS: ALTERNATE PROCEDURES

This appendix provides a procedure for determining zone air distribution effectiveness ( $E_z$ ) for all system types.

**Informative Note:** Table 6-4 provides default values of  $E_z$  that are permitted to be used for the air distribution configurations described in the table. The reference  $E_z$  value of 1 is typical of ideal mixing in the zone. The strategy of removing contaminants or displacing contaminants from the breathing zone may result in an effective  $E_z$  value greater than unity, which is typical of stratified systems.

#### C1. ZONE AIR DISTRIBUTION EFFECTIVENESS

Zone air distribution effectiveness shall be calculated in accordance with Equation C-1:

$$E_z = (C_e - C_s)/(C - C_s) \quad (C-1)$$

where

$E_z$  = zone air distribution effectiveness

$C$  = average contaminant concentration at the breathing zone

$C_e$  = average contaminant concentration at the exhaust

$C_s$  = average contaminant concentration at the supply

**C1.1 Personalized Ventilation Systems.** For the purpose of calculating zone air distribution effectiveness for personalized ventilation systems, the breathing zone shall be 9 ft<sup>2</sup> (0.8 m<sup>2</sup>) centered on each occupant with a height of 4.5 ft (1.4 m) from the floor.

#### C2. MODELED AIR DISTRIBUTION SYSTEM

**C2.1 Computational Model.** The computational fluid dynamics (CFD) model for calculating zone air distribution effectiveness shall be in accordance with the following subsections.

**C2.1.1 Computational Domain.** The computational domain shall comprise all sensible heat sources, all major obstructions to airflow, and all air distribution devices. The calculation domain shall include all boundary walls.

**C2.1.2 Solution Variables.** Analysis shall include the solutions for fluid flow, heat transfer, and chemical species transport. The buoyancy (gravitational) effects shall be included in the calculation procedure.

**C2.1.3 Boundary Conditions.** Sensible heat sources shall be permitted to be modeled as volumetric heat sources to allow the air to pass through the source or as hollow blocks (no mesh inside) specified with either heat flux or constant temperature on the surfaces of the blocks. Boundary walls shall be modeled as adiabatic (zero heat flux), specified heat flux, or specified temperature boundary.

**C2.1.4 Species Transport.** The sources shall be modeled as volumetric source or a boundary flux with known generation rate with zero release velocity. The analysis shall be performed with a uniformly distributed source at the breathing zone level of the occupants. All the boundary walls shall be modeled as impermeable to the chemical species.

**Informative Note:** The species modeled should be a tracer gas, such as CO<sub>2</sub>. Discretion is left to the modeler to determine the appropriate model depending on the design compounds in the zone.

**C2.1.5 Turbulence Model.** Reynolds (ensemble) averaging turbulence models shall be used.

**Informative Note:** RNG and realizable k- $\epsilon$  models meet the requirements of this section.

**C2.1.6 Computational Mesh.** A fine mesh shall be generated near the sensible heat sources, such as occupants and computers, to resolve the thermal plume surrounding these sources. The fine mesh shall be generated on all supply air and return air locations.

**C2.1.7 Solution Convergence.** The solution convergence levels shall include the monitoring of relevant physical quantities, such as temperature or species concentration, at strategic locations. The globally scaled residuals shall be decreased to 10<sup>-3</sup> for all equations except the

energy and species equations, for which the residuals shall be decreased to  $10^{-7}$ . The mass and energy balance shall be calculated up to at least four (4) decimal places.

**Informative Note:** Review of the thermal comfort of occupants in the computational model may be desirable.

**C2.2 Zone Air Distribution Effectiveness.** Zone air distribution effectiveness ( $E_z$ ) shall be computed in accordance with Equation C-1 for each computational cell in the breathing zone. The zone air distribution effectiveness ( $E_z$ ) of the system shall be the average value of the zone air distribution effectiveness of each computational cell within the breathing zone. The analysis shall be performed for both summer cooling conditions and winter heating conditions.

**Informative Note:** Validation of the computational model with physical measurements during design can improve the accuracy of the computational model and the zone air distribution effectiveness of the system. Field measurements could also be performed post building occupancy to verify zone air distribution effectiveness.

**(This appendix is not part of this standard. It is merely informative and does not contain requirements necessary for conformance to the standard. It has not been processed according to the ANSI requirements for a standard and may contain material that has not been subject to public review or a consensus process. Unresolved objections on informative material are not offered the right to appeal at ASHRAE or ANSI.)**

## **INFORMATIVE APPENDIX D INFORMATION ON SELECTED NATIONAL STANDARDS AND GUIDELINES FOR PM<sub>10</sub>, PM<sub>2.5</sub>, AND OZONE**

Standard 62.1, Section 4, requires that the status of compliance with National Ambient Air Quality Standards (NAAQS) shall be determined for the geographical area of the building site. Table D-1 is a representative table presenting the NAAQS information for the United States. Links to detailed information on the ambient air quality standards and contaminant levels for other select counties and regions are as follows:

- U.S. National Ambient Air Quality Standards (NAAQS): [www.epa.gov/green-book](http://www.epa.gov/green-book) and [www.epa.gov/criteria-air-pollutants/naaqs-table](http://www.epa.gov/criteria-air-pollutants/naaqs-table)
- Canadian Ambient Air Quality Standards: [www.ccme.ca/en/current\\_priorities/air/caaqs.html](http://www.ccme.ca/en/current_priorities/air/caaqs.html)
- Hong Kong Air Quality Objectives: [www.epd.gov.hk/epd/english/environmentinhk/air/air\\_quality\\_objectives/air\\_quality\\_objectives.html](http://www.epd.gov.hk/epd/english/environmentinhk/air/air_quality_objectives/air_quality_objectives.html)
- Singapore Air quality Targets: [www.nea.gov.sg/our-services/pollution-control/air-pollution/air-quality](http://www.nea.gov.sg/our-services/pollution-control/air-pollution/air-quality)
- European Commission Air Quality Standards: [ec.europa.eu/environment/air/quality/standards.htm](http://ec.europa.eu/environment/air/quality/standards.htm)
- Brazil Air Quality Standards: [transportpolicy.net/index.php?title=Brazil:\\_Air\\_Quality\\_-\\_Standards](http://transportpolicy.net/index.php?title=Brazil:_Air_Quality_-_Standards)
- World Health Organization (WHO) Air Quality Guideline Values: [www.who.int/mediacentre/factsheets/fs313/en](http://www.who.int/mediacentre/factsheets/fs313/en)

The Clean Air Act ([www.epa.gov/clean-air-act-overview](http://www.epa.gov/clean-air-act-overview)), which was last amended in 1990, requires the U.S. Environmental Protection Agency (USEPA) to set national ambient air quality standards (40 CFR part 50) for pollutants considered harmful to public health and the environment. The Clean Air Act identifies two types of national ambient air quality standards. *Primary standards* provide public health protection, including protecting the health of “sensitive” populations, such as asthmatics, children, and the elderly. *Secondary standards* provide public welfare protection, including protection against decreased visibility and damage to animals, crops, vegetation, and buildings.

USEPA has set NAAQS for six principal pollutants, which are called “criteria” air pollutants ([www.epa.gov/criteria-air-pollutants](http://www.epa.gov/criteria-air-pollutants)). Periodically, the standards are reviewed and may be revised. The current standards are listed in Table D-1. Units of measure for the standards are parts per million (ppm) by volume, parts per billion (ppb) by volume, and micrograms per cubic metre of air ( $\mu\text{g}/\text{m}^3$ ).

**Table D-1 National Ambient Air Quality Standards for the United States**  
([www.epa.gov/criteria-air-pollutants/naaqs-table](http://www.epa.gov/criteria-air-pollutants/naaqs-table))

Pollutant		Primary/ Secondary	Averaging Time	Level	Form
<b>Carbon Monoxide (CO)</b> <a href="http://www.epa.gov/co-pollution/table-historical-carbon-monoxide-co-national-ambient-air-quality-standards-naaqs">www.epa.gov/co-pollution/table-historical-carbon-monoxide-co-national-ambient-air-quality-standards-naaqs</a>		Primary	Eight (8) hours	9 ppm	Not to be exceeded more than once per year
			One (1) hour	35 ppm	
<b>Lead (Pb)</b> <a href="http://www.epa.gov/lead-air-pollution/table-historical-lead-pb-national-ambient-air-quality-standards-naaqs">www.epa.gov/lead-air-pollution/table-historical-lead-pb-national-ambient-air-quality-standards-naaqs</a>		Primary and secondary	Rolling three (3) month average	0.15 µg/m <sup>3</sup> (Note 1)	Not to be exceeded
<b>Nitrogen Dioxide (NO<sub>2</sub>)</b> <a href="http://www.epa.gov/no2-pollution/table-historical-nitrogen-dioxide-national-ambient-air-quality-standards-naaqs">www.epa.gov/no2-pollution/table-historical-nitrogen-dioxide-national-ambient-air-quality-standards-naaqs</a>		Primary	One (1) hour	100 ppb	Ninety-eighth (98th) percentile of one-hour daily maximum concentrations, averaged over three years
		Primary and secondary	One (1) year	53 ppb (Note 2)	Annual mean
<b>Ozone (O<sub>3</sub>)</b> <a href="http://www.epa.gov/ozone-pollution/table-historical-ozone-national-ambient-air-quality-standards-naaqs">www.epa.gov/ozone-pollution/table-historical-ozone-national-ambient-air-quality-standards-naaqs</a>		Primary and secondary	Eight (8) hours	0.070 ppm (Note 3)	Annual fourth-highest daily maximum eight-hour concentration, averaged over three years
<b>Particle Pollution (PM)</b> <a href="http://www.epa.gov/pm-pollution/table-historical-particulate-matter-pm-national-ambient-air-quality-standards-naaqs">www.epa.gov/pm-pollution/table-historical-particulate-matter-pm-national-ambient-air-quality-standards-naaqs</a>	PM2.5	Primary	One (1) year	12.0 µg/m <sup>3</sup>	Annual mean, averaged over three years
		Secondary	One (1) year	15.0 µg/m <sup>3</sup>	Annual mean, averaged over three years
		Primary and secondary	Twenty-four (24) hours	35 µg/m <sup>3</sup>	Ninety-eight (98th) percentile, averaged over three years
	PM10	Primary and secondary	Twenty-four (24) hours	150 µg/m <sup>3</sup>	Not to be exceeded more than once per year on average over three years
<b>Sulfur Dioxide (SO<sub>2</sub>)</b> <a href="http://www.epa.gov/so2-pollution/table-historical-sulfur-dioxide-national-ambient-air-quality-standards-naaqs">www.epa.gov/so2-pollution/table-historical-sulfur-dioxide-national-ambient-air-quality-standards-naaqs</a>		Primary	One (1) hour	75 ppb (Note 4)	Ninety-ninth (99th) percentile of one-hour daily maximum concentrations, averaged over three years
		Secondary	Three (3) hours	0.5 ppm	Not to be exceeded more than once per year

**Note 1:** In areas designated “nonattainment” for the Pb standards prior to the promulgation of the current (2008) standards, and for which implementation plans to attain or maintain the current (2008) standards have not been submitted and approved, the previous standards (1.5 µg/m<sup>3</sup> as a calendar quarter average) also remain in effect.  
**Note 2:** The level of the annual NO<sub>2</sub> standard is 0.053 ppm. It is shown here in terms of ppb for the purpose of clearer comparison to the one-hour standard level.  
**Note 3:** Final rule signed October 1, 2015, and effective December 28, 2015. The previous (2008) O<sub>3</sub> standards additionally remain in effect in some areas. Revocation of the previous (2008) O<sub>3</sub> standards and transitioning to the current (2015) standards will be addressed in the implementation rule for the current standards.  
**Note 4:** The previous SO<sub>2</sub> standards (0.14 ppm 24-hour and 0.03 ppm annual) will additionally remain in effect in certain areas: (a) any area for which it is not yet one year since the effective date of designation under the current (2010) standards, and (b) any area for which an implementation plan providing for attainment of the current (2010) standard has not been submitted and approved and that is designated “nonattainment” under the previous SO<sub>2</sub> standards or is not meeting the requirements of an SIP call under the previous SO<sub>2</sub> standards (40 CFR 50.4[3]). An SIP call is an EPA action requiring a state to resubmit all or part of its State Implementation Plan to demonstrate attainment of the required NAAQS.



**(This appendix is not part of this standard. It is merely informative and does not contain requirements necessary for conformance to the standard. It has not been processed according to the ANSI requirements for a standard and may contain material that has not been subject to public review or a consensus process. Unresolved objectors on informative material are not offered the right to appeal at ASHRAE or ANSI.)**

## **INFORMATIVE APPENDIX E ACCEPTABLE MASS BALANCE EQUATIONS FOR USE WITH THE IAQ PROCEDURE**

When applying the IAQ Procedure from Section 6.3, mass balance analysis may be employed to determine outdoor air ventilation requirements to control concentrations to meet design targets.

Table E-1 presents mass balance equations for analysis of single-zone systems. Figures E-1 and E-2 show representative single-zone systems. A filter may be located in the recirculated airstream (location A) or in the supply (mixed) airstream (location B). The equations do not account for sources within the HVAC system that may occur, such as filter off-gassing, energy recovery carryover of specific gases, or generation of particles or compounds.

Variable-air-volume (VAV) single-zone systems reduce the circulation rate when the thermal load is lower than the design load. This is accounted for by a flow reduction fraction ( $F_r$ ).

A mass balance equation for each design compound or PM<sub>2.5</sub> may be written and used to determine the required outdoor airflow or the breathing zone resultant concentration for the various system arrangements. Six permutations for air-handling and single-zone air distribution systems are described in Table E-1. The mass balance equations for computing the required outdoor airflow and the breathing-zone contaminant concentration at steady-state conditions for each single-zone system are presented in Table E-1.

If the allowable breathing zone design target is specified, the equations in Table E-1 may be solved for the zone outdoor airflow rate ( $V_{OZ}$ ). When the zone outdoor airflow rate is specified, the equations may be solved for the resulting breathing zone design compound or PM<sub>2.5</sub> concentration.

While the calculation methods in this appendix are based on single-zone systems and steady-state analysis, calculation methods that account for multiple-zone and transient effects are also available (see Dols and Walton [2002] in Informative Appendix M).

**Table E-1 Required Zone Outdoor Airflow or Space Breathing Zone Contaminant Concentration with Recirculation and Filtration for Single-Zone Systems**

Required Recirculation Rate			Required Zone Outdoor Airflow ( $V_{oz}$ in Section 6)	Space Breathing Zone Contaminant Concentration
Filter Location	Flow	Outdoor Airflow		
None	VAV	100%	$V_{oz} = \frac{N}{E_z F_r (C_{bz} - C_o)}$	$C_{bz} = C_o + \frac{N}{E_z F_r V_{oz}}$
A	Constant	Constant	$V_{oz} = \frac{N - E_z R V_r E_f C_{bz}}{E_z (C_{bz} - C_o)}$	$C_{bz} = \frac{N + E_z V_{oz} C_o}{E_z (V_{oz} + R V_r E_f)}$
A	VAV	Constant	$V_{oz} = \frac{N - E_z F_r R V_r E_f C_{bz}}{E_z (C_{bz} - C_o)}$	$C_{bz} = \frac{N + E_z V_{oz} C_o}{E_z (V_{oz} + F_r R V_r E_f)}$
B	Constant	Constant	$V_{oz} = \frac{N - E_z R V_r E_f C_{bz}}{E_z [C_{bz} - (1 - E_f)(C_o)]}$	$C_{bz} = \frac{N + E_z V_{oz} (1 - E_f) C_o}{E_z (V_{oz} + R V_r E_f)}$
B	VAV	100%	$V_{oz} = \frac{N}{E_z F_r [C_{bz} - (1 - E_f)(C_o)]}$	$C_{bz} = \frac{N + E_z F_r V_{oz} (1 - E_f) C_o}{E_z F_r V_{oz}}$
B	VAV	Constant	$V_{oz} = \frac{N - E_z F_r R V_r E_f C_{bz}}{E_z [C_{bz} - (1 - E_f)(C_o)]}$	$C_{bz} = \frac{N + E_z V_{oz} (1 - E_f) C_o}{E_z (V_{oz} + F_r R V_r E_f)}$

Symbol or Subscript	Definition
<i>A, B</i>	filter location
<i>V</i>	volumetric flow
<i>C</i>	contaminant concentration
$E_z$	zone air distribution effectiveness
$E_f$	filter efficiency
$F_r$	design flow reduction fraction factor
<i>N</i>	contaminant generation rate
<i>R</i>	recirculation flow factor
Subscript: <i>o</i>	outdoor
Subscript: <i>r</i>	return
Subscript: <i>b</i>	breathing
Subscript: <i>z</i>	zone

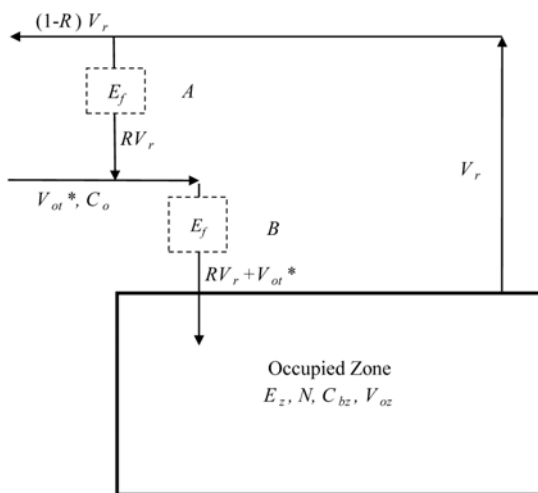

**Figure E-1 Ventilation system schematic—constant-volume system with no infiltration/exfiltration. ( $*V_{ot} = V_{oz}$  for single-zone systems.)**

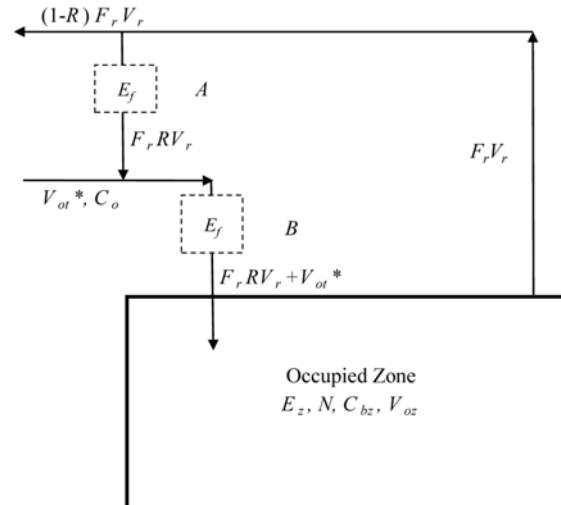

**Figure E-2 Ventilation system schematic—variable-air-volume system with no infiltration/exfiltration. ( $*V_{ot} = V_{oz}$  for single-zone systems.)**

(This appendix is not part of this standard. It is merely informative and does not contain requirements necessary for conformance to the standard. It has not been processed according to the ANSI requirements for a standard and may contain material that has not been subject to public review or a consensus process. Unresolved objectors on informative material are not offered the right to appeal at ASHRAE or ANSI.)

## INFORMATIVE APPENDIX F SIMPLIFIED VENTILATION RATE CALCULATION FOR MULTIPLE-ZONE RECIRCULATING SYSTEMS SERVING ONLY SPECIFIED OCCUPANCY CATEGORIES IN EXISTING BUILDINGS

### F1. USE OF THIS APPENDIX

This appendix is intended to be used to assess ventilation rates in existing buildings for third-party building evaluation programs such as ASHRAE Building EQ (bEQ), Leadership in Energy and Environmental Design for Existing Buildings: Operations and Maintenance (LEED EBOM), Energy Star, etc. Zone minimum primary airflow is included as guidance in evaluating and adjusting minimum box settings. This informative appendix is not intended to be used as the Basis of Design or for regulatory applications.

### F2. OUTDOOR AIR INTAKE

For multiple-zone recirculating systems serving only occupancy categories listed in Table F-1, the target outdoor air intake flow ( $V_{target}$ ) is determined in accordance with Equation F-1. For all other systems,  $V_{target}$  shall be set equal to  $V_{ot}$  in accordance with Section 6.2.4.4. If the minimum outdoor air intake flows measured at the system level meet or exceed  $V_{target}$ , then the system meets the criteria of this informative appendix.

$$V_{target} = \sum_{all\ zones} A_z \times R_s \quad (F-1)$$

where

$A_z$  = zone floor area, the net occupiable floor area of the ventilation zone, ft<sup>2</sup> (m<sup>2</sup>)

$R_s$  = outdoor airflow rate required per unit area as determined from Table F-1

### F3. ZONE MINIMUM PRIMARY AIRFLOW

For each zone, the minimum primary airflow ( $V_{pz-min}$ ) is determined in accordance with Equation F-2.

$$V_{pz-min} = A_z \times R_{pz} \quad (F-2)$$

where

$R_{pz}$  = minimum primary airflow rate required per unit area as determined from Table F-1.  
This is the minimum zone airflow required for ventilation purposes.

**Table F-1 Minimum Outdoor and Primary Airflow Rates**

Occupancy Category	Zone Minimum Airflow			
	Outdoor Airflow Rate $R_o$		Minimum Primary Airflow Rate, $R_{pz}$	
	cfm/ft <sup>2</sup>	L/s·m <sup>2</sup>	cfm/ft <sup>2</sup>	L/s·m <sup>2</sup>
<b>Educational Facilities</b>				
Classrooms (ages 5 to 8)	0.65	3.25	1.12	5.60
Classrooms (ages 9 plus)	0.82	4.10	1.41	7.05
Computer lab	0.65	3.25	1.12	5.60
Media center	0.65	3.25	1.12	5.60
Music/theater/dance	0.72	3.60	1.24	6.20
Multiuse assembly	1.42	7.10	2.45	12.25
<b>General</b>				
Conference/meeting	0.44	2.20	0.76	3.80
Corridors	0.11	0.55	0.19	0.95
<b>Office Buildings</b>				
Breakrooms	0.65	3.25	1.12	5.60
Main entry lobbies	0.19	0.95	0.33	1.65
Occupiable storage rooms for dry materials	0.12	0.60	0.21	1.05
Office space	0.15	0.75	0.26	1.30
Reception areas	0.37	1.85	0.64	3.20
Telephone/data entry	0.63	3.15	1.09	5.45
<b>Public Assembly Spaces</b>				
Libraries	0.30	1.50	0.52	2.60

**(This appendix is not part of this standard. It is merely informative and does not contain requirements necessary for conformance to the standard. It has not been processed according to the ANSI requirements for a standard and may contain material that has not been subject to public review or a consensus process. Unresolved objectors on informative material are not offered the right to appeal at ASHRAE or ANSI.)**

## **INFORMATIVE APPENDIX G APPLICATION**

This appendix contains application and compliance suggestions that are intended to assist users and enforcement agencies in applying this standard.

Although the standard may be applied to both new and existing buildings, the provisions of this standard are not intended to be applied retroactively when the standard is used as a mandatory regulation or code.

For the most part, Standard 62.1 is specifically written for new buildings because some of its requirements assume that other requirements within the standard have been met. In the case of existing buildings, retroactive application and compliance with all the requirements of this standard may not be practical. However, the principles established in this standard may be applied to most existing commercial and institutional buildings. Some existing buildings may achieve acceptable IAQ despite not meeting the requirements of Standard 62.1 due to, for example, good maintenance and capital improvement procedures; building materials that, by virtue of their age, have very low contaminant emission rates; and many other factors.

### **G1. APPLICATION**

**G1.1 New Buildings.** All sections and normative appendices should apply to new buildings falling within the scope of this standard.

**G1.2 Existing Buildings.** The standard should be applied to existing buildings at least in the circumstances described in the following subsections.

**G1.2.1 Additions to Existing Buildings.** All additions to existing buildings should meet the requirements of this standard as if the addition were a new building. An exception may be made when an existing ventilation system is extended to serve the addition. In this case, the existing system components, such as fans and cooling and heating equipment, need not meet the requirements of this standard. However, the extended existing system should remain in compliance with ventilation codes and standards that were in effect at the time it was permitted for construction.

**G1.2.2 Repairs.** Repairing (making operational) existing equipment or other building components does not require the building or any of its components to retroactively comply with this standard.

**G1.2.3 Replacement.** Any component of a building that is removed and replaced should meet the applicable requirements of Section 5, “Systems and Equipment,” of this standard for that component. An exception may be made in cases when replacing a component of like size and kind, provided all requirements of codes and standards used at the time of original system design and installation are met. For example, replacement of an air-conditioning unit with one of similar capacity would not require retroactive compliance with ventilation rates and other requirements of this standard. Unaltered components do not need to be retroactively brought into compliance except when there are substantial alterations (as defined below).

**G1.2.4 Substantial Alterations.** If a building is substantially altered, the requirements of this standard should be met as if the building were new. A building would be considered substantially altered if the cost of the revisions exceeds 50% of the building’s fair market value, excluding the cost of compliance with this standard.

**G1.2.5 Change in Use.** If the space application category, as listed in Table 6-1, changes—such as from office to retail—the minimum ventilation rates required by Section 6, “Procedures,” should be met for that space.

**G1.2.6 Contaminants.** Ventilation requirements of this standard are based on chemical, physical, and biological contaminants that can affect air quality.

**G1.2.7 Thermal Comfort.** Control of thermal comfort is not required by this standard. Requirements for thermal comfort are contained in [ASHRAE Standard 55](#). Note that there are strong correlations between peoples’ perception of IAQ and their perception of thermal comfort.

**G1.2.8 Limitations.** Acceptable IAQ might not be achieved in all buildings meeting the requirements of this standard for one or more of the following reasons:

- a. Because of the diversity of sources and contaminants in indoor air
- b. Because of the many other factors that might affect occupant perception and acceptance of IAQ, such as air temperature, humidity, noise, lighting, and psychological stress
- c. Because of the range of susceptibility in the population
- d. Because outdoor air brought into the building might be unacceptable or might not be adequately cleaned

---

The following section provides suggested model code language.

## **APPLICATION AND COMPLIANCE**

### **Application**

**New Buildings.** All sections and normative appendices apply to new buildings falling within the scope of this standard.

### **Existing Buildings**

**Additions to Existing Buildings.** All additions to existing buildings within the scope of this standard shall meet the requirements of all sections and normative appendices.

**Exception:** When an existing ventilation system is extended to serve an addition, the existing system components, such as fans and cooling and heating equipment, need not meet the requirements of this standard. However, the extended existing system must remain in compliance with ventilation codes and standards that were in effect at the time it was permitted for construction.

**Repairs.** Repairing (making operational) existing equipment or other building components shall be allowed without requiring the building or any of its components to comply with this standard.

**Replacement.** Any component of a building that is removed and replaced shall meet the applicable requirements of Section 5, "Systems and Equipment," of this standard for that component. Unaltered components are not required to be brought into compliance except as required due to a change in use.

**Exception:** Replacement of a building component or individual piece of equipment with a component of like size and kind, provided that all requirements of codes effective at the time of original system design and installation are met. For example, replacement of an air-conditioning unit with one of similar capacity would not require that the ventilation rate requirements and other requirements of this standard be met.

**Substantial Alterations.** If a building is substantially altered, all sections and normative appendices of this standard shall be met as if the building were new. A building shall be considered substantially altered if the cost of the revisions exceeds 50% of the building's fair market value, excluding the cost of compliance with all sections and normative appendices of this standard.

**Change in Use.** If the space application category as listed in Table 2 changes, such as from office to retail, the minimum ventilation rates required by Section 6, "Procedures," shall be met for that space.

### **Compliance**

Demonstrating that acceptable IAQ has been achieved, such as by measuring contaminant concentrations or surveying occupants, is not required by this standard except where required by the IAQ Procedure.

**(This appendix is not part of this standard. It is merely informative and does not contain requirements necessary for conformance to the standard. It has not been processed according to the ANSI requirements for a standard and may contain material that has not been subject to public review or a consensus process. Unresolved objectors on informative material are not offered the right to appeal at ASHRAE or ANSI.)**

## **INFORMATIVE APPENDIX H DOCUMENTATION**

This appendix summarizes the requirements for documentation contained in the body of the standard using a series of templates that summarizes the design criteria used and assumptions made to comply with this standard. One way to comply with the documentation requirements of the standard is to complete these templates as appropriate during the project design process.

### **H1. OUTDOOR AIR QUALITY**

Section 4.3 of this standard requires an investigation of the outdoor air quality in the vicinity of the project site. This template offers a means of documenting the results of both the regional and local investigations and the conclusions reached concerning the acceptability of the outdoor air quality for indoor ventilation.

### **H2. BUILDING VENTILATION DESIGN CRITERIA**

This template provides a means of documenting significant design criteria for the overall building. Only the last column, in accordance with Section 5.1.3, is specifically required by the standard. The other columns are motivated by the general documentation requirement described in Section 6.6.

### **H3. VENTILATION RATE PROCEDURE**

Section 6.2 permits the use of this prescription-based procedure to design ventilation systems. This template documents the assumptions made when using this procedure as required by Sections 5.18.4 and 6.6.

### **H4. IAQ PROCEDURE**

Section 6.3 permits the use of this performance-based procedure to design ventilation systems. This template documents the design criteria and assumptions made when using this procedure and justification of the design approach, as required by Section 6.3.2.

<b>Regional Outdoor Air Quality Pollutants</b>	<b>Attainment or Nonattainment According to the U.S. Environmental Protection Agency (USEPA)</b>
Particulates (PM <sub>2.5</sub> )	(Yes/No)
Particulates (PM <sub>10</sub> )	(Yes/No)
Carbon monoxide—1 hour/8 hours	(Yes/No)
Ozone	(Yes/No)
Nitrogen dioxide	(Yes/No)
Lead	(Yes/No)
Sulfur dioxide	(Yes/No)
<b>Local Outdoor Air Quality Survey</b>	<b>Date:</b> _____ <b>Time:</b> _____
(a) Area surveyed	(Brief description of the site)
(b) Nearby facilities	(Brief description type of facilities—industrial, commercial, hospitality, etc.)
(c) Odors or irritants	(List and describe)
(d) Visible plumes	(List and describe)
(e) Nearby sources of vehicle exhaust	(List and describe)
(f) Prevailing winds	(Direction)
(g) Other observations	
(h) Conclusions	(Remarks concerning the acceptability of the outdoor air quality)

**Building Ventilation Design Criteria**

<b>Total Building Outdoor Air Intake</b>	<b>Total Building Exhaust Air (see Section 5.11)</b>	<b>Outdoor Air Cleaning Required (See Section 6.1.4)</b>		<b>Indoor Air Dew Point (Section 5.10)</b>		<b>Air Balancing (See Section 5.1.3)</b>
		<b>Particulate Matter</b>	<b>Ozone</b>	<b>Peak Outdoor DP at Dehumidification Design Condition</b>	<b>Calculated Space DP at Concurrent Outdoor Condition</b>	
(cfm)	(cfm)	(Yes/No)	(Yes/No)	(Dew point)	(Dew point)	(NEBB, AABC, etc.)



Space Identification	Space Type	Occupant Density	Rate/Person	Rate/SF	Zone Air Distribution Effectiveness	System Ventilation Efficiency	Class of Air
(List number or name of each ventilation zone, such as office number or name, retail space name, or classroom number.)	(List occupancy category of the space from Table 6-1, such as Office Space, Retail Sales, Classroom Ages 5 to 8, etc.)	(People/ft <sup>2</sup> or m <sup>2</sup> )	(cfm or L/s)	(cfm or L/s)	(Table 6-4)	(Section 6.2.5; Normative Appendix A)	(Tables 6-1 or 6-3; include justification for classification if not in these tables)

**IAQ Procedure Assumptions**

Contaminant of Concern	Contaminant Source	Contaminant Strength	Contaminant Target Concentration			Perceived IAQ	Design Approach
			Limit	Exposure Period	Cognizant Authority Reference		
(Identify and list)	(Identify and list)	(Determine and list)	(List)	(List)	(List)	(Percentage of satisfied building occupants)	(Select from Section 6.3.4 and include justification.)

(This appendix is not part of this standard. It is merely informative and does not contain requirements necessary for conformance to the standard. It has not been processed according to the ANSI requirements for a standard and may contain material that has not been subject to public review or a consensus process. Unresolved objections on informative material are not offered the right to appeal at ASHRAE or ANSI.)

## INFORMATIVE APPENDIX I RATE RATIONALE

Table I-1 provides description and rationale for the Ventilation Rate Procedure rates in Table 6-1, “Minimum Ventilation Rates in Breathing Zone.” This information may be helpful to designers and other practitioners.

**Table I-1 Rate Rationale (see Table 6-1)**

Occupancy Category	Description/Rationale	People Outdoor Air Rate, cfm/person	People Outdoor Air Rate, L/s/person	Area Outdoor Air Rate, cfm/ft <sup>2</sup>	Area Outdoor Air Rate, L/s-m <sup>2</sup>	Air Class
<b>Correctional Facilities</b>						
Booking/waiting	Occupant activity varies between sedentary and moderate walking. Occupants are generally more vocal. Occupants may not be as well-groomed as typical occupants. Occupant stress levels are generally high. All of which result in higher metabolic rates. There are no significant space-related contaminants.	7.5	3.8	0.06	0.3	2
Cell	Occupant activity is primarily sedentary (seated or sleeping). There are typically higher levels of space-related contaminants due to presence of a water closet, sink, and stored clothing. The presence of a water closet is the primary reason why this space has an Air Class of 2.	5	2.5	0.12	0.6	2
Day room	Occupant activity is primarily sedentary (seated, watching television). There are no significant space-related contaminants.	5	2.5	0.06	0.3	1
Guard stations	Occupant activity is primarily sedentary (seated). There are no significant space-related contaminants.	5	2.5	0.06	0.3	1
<b>Educational Facilities</b>						
Art classroom	Occupant activity is moderate. There is considerable aerobic activity in addition to the occupants being very vocal. Also, the occupants are primarily children with higher metabolic rates. There are significant space-related contaminants, including open paints, glues, and cleaning agents. The presence of these open contaminants result in this space being classified as Air Class 2.	10	5	0.18	0.9	2
Classrooms (ages 5 through 8)	Occupant activity is primarily sedentary (seated or light walking). However, occupants are generally more vocal. Also, the occupants are primarily children with higher metabolic rates and often more bioeffluents. There are some significant space-related contaminants, typically stored arts-and-crafts supplies and cleaning agents.	10	5	0.12	0.6	1

**Table I-1 Rate Rationale (see Table 6-1) (Continued)**

Occupancy Category	Description/Rationale	People Outdoor Air Rate, cfm/person	People Outdoor Air Rate, L/s/person	Area Outdoor Air Rate, cfm/ft <sup>2</sup>	Area Outdoor Air Rate, L/s·m <sup>2</sup>	Air Class
Classrooms (age 9 plus)	Occupant activity is primarily sedentary (seated or light walking). However, occupants are generally more vocal. Also, the occupants are primarily children with higher metabolic rates and often more bioeffluents. There are some significant space-related contaminants, typically stored arts-and-crafts supplies and cleaning agents.	10	5	0.12	0.6	1
Computer lab	Occupant activity is primarily sedentary (seated or light walking). However, occupants are generally more vocal. Also, the occupants can be children/young adults with higher metabolic rates. There are some significant space-related contaminants, typically toner cartridges and paper.	10	5	0.12	0.6	1
Daycare (through age 4)	Occupant activity is moderate. There is considerable aerobic activity in addition to the occupants being very vocal. Also, the occupants are primarily young children with higher metabolic rates. There are significant space-related contaminants, including diapers, arts-and-crafts supplies, and cleaning agents. These contaminants, particularly the diapers, result in this space being classified as Air Class 2.	10	5	0.18	0.9	2
Lecture classroom	Occupant activity is primarily sedentary (seated or light walking). However, occupants are generally more vocal, resulting in higher metabolic rates. There are no significant space-related contaminants.	7.5	3.8	0.06	0.3	1
Lecture hall (fixed seats)	Occupant activity is primarily sedentary (seated or light walking). However, occupants are generally more vocal, resulting in higher metabolic rates. There are no significant space-related contaminants.	7.5	3.8	0.06	0.3	1
Media center	Occupant activity is primarily sedentary (seated or light walking). However, occupants are generally more vocal. Also, the occupants are primarily children/young adults with higher metabolic rates and often more bioeffluents. There are some significant space-related contaminants, typically toner cartridges and paper (both loose leaf and bound).	10	5	0.12	0.6	1
Multiuse assembly	Occupant activity is primarily sedentary (seated or light walking). However, occupants are generally more vocal, resulting in higher metabolic rates. There are no significant space-related contaminants.	7.5	3.8	0.06	0.3	1
Music/theater/dance	Occupant activity is high. There is considerable aerobic activity in addition to the occupants being very vocal. There are no significant space-related contaminants.	10	5	0.06	0.3	1
Science laboratories	Occupant activity is moderate. There is considerable aerobic activity in addition to the occupants being very vocal. Also, the occupants are primarily children with higher metabolic rates. There are significant space-related contaminants, including open chemicals and cleaning agents. The presence of these open contaminants result in this space being classified as Air Class 2. OSHA regulated exposure limits must be maintained, ensuring Class 2 defined air is present. This condition is covered in Table 6-2.	10	5	0.18	0.9	2

Table I-1 Rate Rationale (see Table 6-1) (Continued)

Occupancy Category	Description/Rationale	People Outdoor Air Rate, cfm/person	People Outdoor Air Rate, L/s/person	Area Outdoor Air Rate, cfm/ft <sup>2</sup>	Area Outdoor Air Rate, L/s/m <sup>2</sup>	Air Class
University/college laboratories	Occupant activity is moderate. There is considerable aerobic activity in addition to the occupants being very vocal. Also, the occupants have higher metabolic rates. There are significant space-related contaminants, including open chemicals and cleaning agents. The presence of these open contaminants results in this space being classified as Air Class 2. OSHA regulated exposure limits must be maintained, ensuring Class 2 defined air is present. This condition is covered in Table 6-2.	10	5	0.18	0.9	2
Wood/metal shop	Occupant activity is moderate. There is considerable aerobic activity in addition to the occupants being very vocal. Also, the occupants can be children/young adults with higher metabolic rates. There are significant space-related contaminants, including sawdust, oils, metal shavings, and chemical agents. The presence of these open contaminants result in this space being classified as Air Class 2.	10	5	0.18	0.9	2
<b>Food and Beverage Service</b>						
Bars, cocktail lounges	Occupant activity is moderate (standing, talking, eating/drinking, waiting tables). The presence of large quantities of open drinks and prepared foods creates higher levels of space-related contaminants. The associated food and drink odors result in this space being classified as Air Class 2.	7.5	3.8	0.18	0.9	2
Cafeteria/fast-food dining	Occupant activity is moderate (standing, talking, eating, cleaning tables). The presence of large quantities of unpackaged, prepared foods creates higher levels of space-related contaminants. The associated food odors result in this space being classified as Air Class 2.	7.5	3.8	0.18	0.9	2
Kitchen	Occupant activity is very active (walking, talking, eating, food preparation and cooking). The presence of large quantities of unpackaged, cooking prepared foods creates higher levels of space-related contaminants. The associated food odors result in this space being classified as Air Class 2.	7.5	3.8	0.12	0.6	2
Restaurant dining rooms	Occupant activity is moderate (standing, talking, eating, waiting tables). The presence of large quantities of unpackaged, prepared foods creates higher levels of space-related contaminants. The associated food odors result in this space being classified as Air Class 2.	7.5	3.8	0.18	0.9	2
<b>Food and Beverage Service, General</b>						
Break rooms	Occupant activity is primarily sedentary (seated). There are limited space-related contaminants.	5	2.5	0.06	0.3	
Coffee stations	Occupant activity is primarily sedentary. There are limited space-related contaminants.	5	2.5	0.06	0.3	
Conference/meeting	Occupant activity is primarily sedentary (seated). There are no significant space-related contaminants.	5	2.5	0.06	0.3	1
Corridors	Persons passing through the corridor are considered to be transitory and thus not occupants. There are no significant space-related contaminants.	—	—	0.06	0.3	1

**Table I-1 Rate Rationale (see Table 6-1) (Continued)**

Occupancy Category	Description/Rationale	People Outdoor Air Rate, cfm/person	People Outdoor Air Rate, L/s/person	Area Outdoor Air Rate, cfm/ft <sup>2</sup>	Area Outdoor Air Rate, L/s·m <sup>2</sup>	Air Class
Occupiable storage rooms for liquids or gels	Occupant activity is primarily sedentary (seated). The concentration of stored products increases the level of space-related contaminants. Current ventilation rate is consistent with other minimal/transient occupancy environments.	5	2.5	0.12	0.6	2
<b>Hotels, Motels, Resorts, Dormitories</b>						
Barracks sleeping areas	Occupant activity is primarily sedentary (sleeping). There are no significant space-related contaminants.	5	2.5	0.06	0.3	1
Bedroom/living room	Occupant activity is primarily sedentary (seated or sleeping). There are no significant space-related contaminants.	5	2.5	0.06	0.3	1
Laundry rooms, central	Occupant activity is primarily moderate. There are often usual space-related contaminants related to cleaning.	5	2.5	0.12	0.6	2
Laundry rooms within dwelling units	Occupant activity is primarily moderate. There are often usual space-related contaminants related to cleaning.	5	2.5	0.12	0.6	1
Lobbies/prefunction	Occupant activity is primarily standing and light walking. However, occupants are generally more vocal, resulting in higher metabolic rates. There are no significant space-related contaminants.	7.5	3.8	0.06	0.3	1
Multipurpose assembly	Occupant activity is primarily sedentary (seated or light walking). There are no significant space-related contaminants.	5	2.5	0.06	0.3	1
<b>Miscellaneous Spaces</b>						
Banks or bank lobbies	Occupant activity is primarily standing and light walking. However, occupants are generally more vocal, resulting in higher metabolic rates. There are no significant space-related contaminants.	7.5	3.8	0.06	0.3	
Bank vaults/safe deposit	Occupant activity is light, typically standing. There are no significant space-related contaminants.	5	2.5	0.06	0.3	2
Computer (not printing)	Occupant activity is primarily sedentary (seated). There are no significant space-related contaminants.	5	2.5	0.06	0.3	1
Freezer and refrigerated spaces (<50°F [10°C])	Refrigerated warehouse spaces are significantly different from conventional warehouses in a number of ways. The low temperatures will slow the emission of contaminants, such as VOCs, from the materials stored in the space; the characteristics of the items being stored will be different; and the amount of time spent in the space by occupants may be shorter (particularly for spaces kept at subfreezing temperatures).	10	5	0	0	2

Table I-1 Rate Rationale (see Table 6-1) (Continued)

Occupancy Category	Description/Rationale	People Outdoor Air Rate, cfm/person	People Outdoor Air Rate, L/s/person	Area Outdoor Air Rate, cfm/ft <sup>2</sup>	Area Outdoor Air Rate, L/s/m <sup>2</sup>	Air Class
General manufacturing (excludes heavy industrial and processes using chemicals)	Occupant activity is moderate (standing, walking, assembly). Moderate levels of space-related contaminants are expected. The unknown nature of the contaminants leads to a category of Air Class 3.	10	5	0.18	0.9	3
Pharmacy (prep area)	Occupant activity is primarily light work and standing. There are space-related contaminants, including open containers of liquid medicines. The presence of these open containers results in this space being classified as Air Class 2.	5	2.5	0.18	0.9	2
Photo studios	Occupant activity is primarily standing and light work. There are large quantities of chemicals, many of them open, resulting in higher levels of space-related contaminants.	5	2.5	0.12	0.6	1
Shipping/receiving	Persons moving materials have a higher level of activity. The flow of products increases the level of space-related contaminants in addition to the typical use of forklifts.	10	5	0.12	0.6	1
Sorting, packing, light assembly	Occupant activity is moderate (standing, walking, assembly). There may be moderate levels of space-related contaminants.	7.5	3.8	0.12	0.6	2
Telephone closets	This should be handled as unoccupied space.					
Transportation waiting	Occupant activity is primarily standing and moderate-to-heavy walking. There are no significant space-related contaminants.	7.5	3.8	0.06	0.3	1
Warehouses	Occupant activity is moderate (standing, walking, assembly). There may be moderate levels of space-related contaminants.	10	5	0.06	0.3	2
<b>Office Buildings</b>						
Breakrooms	Occupant activity is primarily sedentary (seated). There are limited space-related contaminants.	5	2.5	0.06	0.3	1
Main entry lobbies	Occupant activity is primarily transitory light walking. There are few anticipated space-related contaminants.	5	2.5	0.06	0.3	1
Occupiable storage rooms for dry materials	Occupant activity is primarily sedentary (seated). The concentration of stored products increases the level of space-related contaminants; however, dry material emissions are expected to be low.	5	2.5	0.06	0.3	1
Office space	Occupant activity is primarily sedentary (seated). There are no significant space-related contaminants.	5	2.5	0.06	0.3	1

**Table I-1 Rate Rationale (see Table 6-1) (Continued)**

Occupancy Category	Description/Rationale	People Outdoor Air Rate, cfm/person	People Outdoor Air Rate, L/s/person	Area Outdoor Air Rate, cfm/ft <sup>2</sup>	Area Outdoor Air Rate, L/s·m <sup>2</sup>	Air Class
Reception areas	Occupant activity is primarily sedentary (seated). There are no significant space-related contaminants.	5	2.5	0.06	0.3	1
Telephone/data entry	Occupant activity is primarily sedentary (seated). There are no significant space-related contaminants.	5	2.5	0.06	0.3	1
<b>Public Assembly Spaces</b>						
Auditorium seating area	Occupant activity is primarily sedentary (seated). There are no significant space-related contaminants.	5	2.5	0.06	0.3	1
Courtrooms	Occupant activity is primarily sedentary (seated). There are no significant space-related contaminants.	5	2.5	0.06	0.3	1
Legislative chambers	Occupant activity is primarily sedentary (seated). There are no significant space-related contaminants.	5	2.5	0.06	0.3	1
Libraries	Occupant activity is primarily sedentary (seated or light walking). The large quantities of books create higher levels of space-related contaminants (dust and odors).	5	2.5	0.12	0.6	1
Lobbies	Occupant activity is primarily sedentary (seated or light walking). There are no significant space-related contaminants.	5	2.5	0.06	0.3	1
Museums (children's)	Occupant activity is moderate. There is considerable aerobic activity in addition to the occupants being very vocal. Also, the occupants are typically young children with higher metabolic rates. There are typically some significant space-related contaminants, such as food and drink.	7.5	3.8	0.12	0.6	1
Museums/galleries	Occupant activity is primarily standing and light walking. However, occupants are generally more vocal, resulting in higher metabolic rates. There are no significant space-related contaminants.	7.5	3.8	0.06	0.3	1
Places of religious worship	Occupant activity is primarily sedentary (seated). There are no significant space-related contaminants.	5	2.5	0.06	0.3	1
<b>Retail</b>						
Sales (except as below)	Occupant activity is moderate. There is considerable occupant movement, including carrying packages and being more vocally active. The presence of new merchandise creates higher levels of space-related contaminants. This is primarily the reason for the space being classified as Air Class 2.	7.5	3.8	0.12	0.6	2
Barber shop	Occupant activity is primarily sedentary, with moderate work being performed by the staff. Occupants are generally more vocal, resulting in higher metabolic rates. There are some significant space-related contaminants (shampoos, disinfecting agents, high levels of human hair). However, these are directly related to the occupancy rather than the floor area. This is the primary reason why this space is classified as Air Class 2.	7.5	3.8	0.06	0.3	2



Table I-1 Rate Rationale (see Table 6-1) (Continued)

Occupancy Category	Description/Rationale	People Outdoor Air Rate, cfm/person	People Outdoor Air Rate, L/s/person	Area Outdoor Air Rate, cfm/ft <sup>2</sup>	Area Outdoor Air Rate, L/s·m <sup>2</sup>	Air Class
Beauty and nail salons	Occupant activity is primarily sedentary, with moderate work being performed by the staff. Occupants are generally more vocal, resulting in higher metabolic rates. There are some significant space-related contaminants (shampoos, disinfecting agents, high levels of hair).	20	10	0.12	0.6	2
Coin-operated laundries	Occupant activity is primarily moderate-to-heavy walking and may include carrying packages. There are some significant space-related contaminants (detergents, disinfecting agents, soiled laundry). However, these are directly related to the occupancy rather than the floor area. This is the primary reason why this space is classified as Air Class 2.	7.5	3.8	0.12	0.6	2
Mall common areas	Occupant activity is primarily moderate to heavy walking and may include carrying packages. Occupants are generally more vocal, resulting in higher metabolic rates. There are no significant space-related contaminants.	7.5	3.8	0.06	0.3	1
Pet shops (animal areas)	Occupant activity is moderate (standing, talking, stooping, walking, and carrying packages). The concentration of animals of various species in containment creates higher levels of space-related contaminants. This concentration of animals, and the fact that they are kept in open containment, results in this space being classified as Air Class 2.	7.5	3.8	0.18	0.9	2
Supermarket	Occupant activity is primarily moderate to heavy walking and may include carrying packages. There are no significant space-related contaminants.	7.5	3.8	0.06	0.3	1
<b>Sports and Entertainment</b>						
Bowling alley (seating)	Occupant activity is moderate (seated, standing, walking, talking, drinking). The presence of open food and drink creates moderately high levels of significant contaminants.	10	5	0.12	0.6	1
Disco/dance floors	Occupant activity is high. There is considerable aerobic activity. There are often considerable quantities of open drink, creating high levels of space-related contaminants related to the people using the space.	20	10	0.06	0.3	1
Gambling casinos	Occupant activity is moderate (seated, standing, walking, talking, drinking). The presence of open food and drink creates moderately high levels of significant contaminants.	7.5	3.8	0.18	0.9	1
Game arcades	Occupant activity is moderate (seated, standing, walking, talking, drinking). The presence of open food and drink creates moderately high levels of significant contaminants.	7.5	3.8	0.18	0.9	1
Gym, stadium (play area)	Occupant activity is high. There is considerable aerobic activity. There are no significant space-related contaminants. Occupancy is variable, and the high area outdoor air rate compensates for the varying occupancy and local source. CO <sub>2</sub> -based demand controlled ventilation in these spaces should consider that the volume per person in these spaces is typically large, which means that CO <sub>2</sub> concentration changes will have longer than usual lag times behind occupancy changes.	20	10	0.18	0.9	2



**Table I-1 Rate Rationale (see Table 6-1) (Continued)**

Occupancy Category	Description/Rationale	People Outdoor Air Rate, cfm/person	People Outdoor Air Rate, L/s/person	Area Outdoor Air Rate, cfm/ft <sup>2</sup>	Area Outdoor Air Rate, L/s/m <sup>2</sup>	Air Class
Health club/aerobics room	Occupant activity is high. There is considerable aerobic activity in addition to the occupants being very vocal. There are significant space-related contaminants related to the people using the space.	20	10	0.06	0.3	2
Health club/weight rooms	Occupant activity is high. There is considerable aerobic activity in addition to the occupants being very vocal. There are significant space-related contaminants related to the people using the space.	20	10	0.06	0.3	2
Spectator areas	Occupant activity is moderate. While the occupants may be primarily seated, there is considerable vocal activity, as well as standing, cheering, and walking to concessions, etc. There are often considerable quantities of open food and drink, creating high levels of space-related contaminants.	7.5	3.8	0.06	0.3	1
Sports arena (play area)	Occupant activity is high. There is considerable aerobic activity. Occupancy is variable, and the high area outdoor air rate compensates for the varying occupancy and local sources. The presence of playing surface cleaning/resurfacing equipment results in significantly high levels of space-related contaminants.	20	10	0.18	0.9	2
Stages, studios	Occupant activity is moderate. While the occupants may be primarily seated, there is considerable vocal activity, as well as standing, cheering, and walking to concessions, etc. The stage props result in higher levels of space-related contaminants. Contaminant level is not high enough to justify an Air Class 2.	10	5	0.06	0.3	1
Swimming (pool and deck)	While the occupant activity (swimming) is high, it is primarily anaerobic. Occupancy is variable, and the high area outdoor air rate compensates for the varying occupancy and local source. Also, the bioeffluents, such as sweat are discharged into the water rather than the air. For these reasons, there is no occupancy-related outdoor air rate. The high level of chemicals in the pool water that are absorbed into the air as the pool water evaporates create exceptionally high levels of space-related contaminants. The presence of these chemicals, and their noxious odor, result in the space being classified as Air Class 2.	—	—	0.48	2.4	2
<b>Transient Residential</b>						
Common corridors	Persons passing through the corridor are considered to be transitory and thus not occupants. There are no significant space-related contaminants.	—	—	0.06	0.3	—
Dwelling unit	Occupant activity is variable. There may be moderate levels of space-related contaminants that are under the control of the occupants.	5	2.5	0.06	0.3	—

**(This appendix is not part of this standard. It is merely informative and does not contain requirements necessary for conformance to the standard. It has not been processed according to the ANSI requirements for a standard and may contain material that has not been subject to public review or a consensus process. Unresolved objections on informative material are not offered the right to appeal at ASHRAE or ANSI.)**

## **INFORMATIVE APPENDIX J INFORMATION ON NATURAL VENTILATION**

### **J1. OUTDOOR AIR QUALITY DATA**

Outdoor air quality data may be considered valid if it is demonstrated that the data are both physically representative and spatially representative.

Physically representative data accurately reflect the air quality conditions at the monitoring station from which they are derived. Data are considered physically representative if they are obtained from

- a. reports of historical levels of air pollutants published by the relevant local, regional, or federal entity with statutory responsibility for collecting and reporting air quality information in accordance with applicable air quality regulations, or
- b. an on-site monitoring campaign that is verifiably comparable to local, regional, or federal guidelines and methods for demonstration of compliance with applicable air quality regulations.

Spatially representative data are collected from a monitoring site that may differ from the proposed project location but is informative of the air quality conditions at the proposed project location. Data may be considered spatially representative if they are

- c. the same as those used by the entity charged with demonstrating regulatory compliance for the geographic region that includes the proposed project location, or
- d. derived from an on-site monitoring campaign that also meets the requirement stated by criteria (b) of this annotation.

### **J2. NATURAL VENTILATION RATE**

When calculating the ventilation rate, specific path(s) of the intended airflow passage must first be determined along with flow directions. There are two driving forces for natural ventilation: buoyancy and wind. The two driving forces can work cooperatively or competitively based on the environmental conditions of wind speed, direction, indoor/outdoor air/surface temperatures, as well as the intentional airflow path and mechanisms.

- a. In the case of an engineered natural ventilation system that results in multiple flow scenarios, each must be examined and considered separately.
- b. Specific pressure-based calculation of natural ventilation flow rate is documented in *ASHRAE Handbook—Fundamentals*, Chapter 16, Section 6:
  1. Buoyancy-induced airflow can be calculated following Equation 38.
  2. Wind-driven airflow can be calculated following Equation 37.
  3. The overall pressure (driven by both wind and stack effect) converted to resulting pressure difference between openings can found in Equation 36.

For obtaining wind-driven pressure, several methods are available:

- a. *ASHRAE Handbook—Fundamentals*, Chapter 24, provides a method to convert wind speed and direction into pressure coefficients that can be used to determine wind-driven pressure.
- b. CIBSE AM10, Chapter 4, provides a method to account for wind-driven ventilation and outlines specific challenges to it in Section 4.4.1.
- c. If the building has undergone wind tunnel test for structural stress, the same test can provide detailed pressure coefficients.
- d. Outdoor airflow simulation (such as computational-fluid-dynamics-based simulation) can be used to obtain the specific flow condition at the intended openings.

For intended openings that are large, such as open atrium or open balcony, and/or when the flow path is not well defined, such as when only single or single-side openings are available, the pressure-based method can be invalid, and outdoor-indoor linked simulation should be used.

**Table J-1 Ventilation Intensity Brackets**

Bracket	(L/s)·m <sup>2</sup>	cfm/ft <sup>2</sup>	Commonly Encountered Space Typologies Bracket
1	0.0 to 1.0	0.0 to 0.2	Office, living room, main entry lobby
2	1.0 to 2.0	0.2 to 0.4	Reception area, general manufacturing, kitchen, lobby
3	2.0 to 3.0	0.4 to 0.6	Classroom, daycare
4	3.0 to 4.0	0.6 to 0.8	Restaurant dining room, places of religious worship
5	4.0 to 5.5	0.6 to 1.1	Auditorium, health club/aerobics room, bar, gambling

Not addressed: Lecture Hall and spectator areas (6 [L/s]/m<sup>2</sup>) and disco/dance floors (10.3 [L/s]/m<sup>2</sup>)

### J3. PRESCRIPTIVE PATH A CALCULATIONS

**J3.1 Ventilation Intensity.** Spaces have been defined by a ventilation intensity, which represents the amount of flow rate needed per Equation 6-1, divided by the floor area of the space. Its units are (L/s)/m<sup>2</sup> of floor area or cfm/ft<sup>2</sup> of floor area.

$$\text{Ventilation Intensity} = \frac{V_{bz}}{A_z} = \frac{R_p \times P_z + R_a \times A_z}{A_z} \quad (\text{J-1})$$

The ventilation intensity brackets in Table J-1 are used.

**J3.2 Single Openings.** The flow through a single sharp opening due to bidirectional buoyancy-driven flow ( $V_{bd\_sharp}$ ) (see Etheridge and Sandberg [1996] in Informative Appendix M) is expressed as follows:

$$V_{so\_sharp} = 0.21 \times A_w \times \sqrt{g H_s \frac{\Delta T}{T_{ref}}} \quad (\text{J-2})$$

where

$A_w$  = free unobstructed area of the window, or openable area

$\Delta T$  = temperature difference between indoors and outdoors. Given the conservative nature of a prescriptive path, a temperature difference of 1°C (1.8°F) is assumed for these calculations. In reality, this temperature will depend on the internal gains in the space and will likely be higher than 1°C (1.8°F), leading to higher airflows (and a smaller window area requirement).

$H_s$  = vertical dimension of the opening

$g$  = gravity constant

$T_{ref}$  = reference temperature in Kelvin (or Rankine), typically equal to  $T_{in}$ ,  $T_{out}$  or an expected average. A reference temperature of 21°C (70°F, 294K) was assumed for these calculations.

A safety factor is incorporated assuming that an awning window is used. Awning (or top-hinged) windows are among the most common windows used for natural ventilation, and, because of their uneven vertical area distribution, are more inefficient than a sliding window (sharp opening) at driving flow. An efficiency  $\epsilon_v$  of around 83% (value used in these calculations) when compared to sliding windows is inferred from

$$V_{so} = V_{so\_sharp} \times \epsilon_w \quad (\text{J-3})$$

Assuming a height-to-width ratio for the window of  $R_{H/W}$  ( $R = H/W$ ), the window area can be rewritten as

$$A_w = \frac{H_s^2}{R_{H/W}} \quad (\text{J-4})$$

The required openable area as a fraction of the zone's floor area is therefore calculated by equating the bidirectional buoyancy-driven flow through a single awning opening ( $V_{so}$ ) to the goal flow rate ( $V_{bz}$ ) obtained from Table 6-1.

$$V_{so} = V_{bz} \quad (\text{J-5})$$

And solving for window area,

$$\frac{A_w}{A_z} = \left( \frac{V_{bz}}{0.21 \times 0.83 \times R_{H/W}^4 \times \sqrt{g \frac{\Delta T}{T_{ref}}}} \right)^{4/5} \times \frac{1}{A_z} \times 100 \quad (J-6)$$

**J3.3 Vertically Spaced Openings.** The flow rate  $V_{vs}$  through vertically spaced openings of areas  $A_s$  (the smallest sum of opening areas, either upper openings or lower openings) and  $A_l$  (the largest sum of opening areas, either upper openings or lower openings) is obtained using the following equation:

$$V_{vs} = A_{eff} \times C_d \times \sqrt{2g\Delta H \frac{\Delta T}{T_{ref}}} \quad (J-7)$$

where

$A_{eff}$  = effective window area, defined as

$$A_{eff} = \frac{1}{\sqrt{\frac{1}{A_s^2} + \frac{1}{A_l^2}}} = \frac{A_s}{\sqrt{1 + R^2}} = \frac{A_w}{\sqrt{1 + R^2} \times \left(1 + \frac{1}{R}\right)} \quad (J-8)$$

$A_w$  = is the total sum of all opening areas

$$A_w = A_s + A_l \quad (J-9)$$

$R$  = area ratio between  $A_s$  and  $A_l$

$$R = \frac{A_s}{A_l} \quad (J-10)$$

$\Delta H$  is the shortest vertical distance between the center of the lowest openings and that of the upper openings.

All other constants are the same as in the single opening scenario.

The required openable area as a fraction of the zone's floor area is therefore calculated by equating the flow through two sets of vertically spaced openings  $V_{vs}$  to the goal flow rate  $V_{bz}$  obtained from Table 6-1.

$$V_{vs} = V_{bz} \quad (J-11)$$

Solving for window area:

$$\frac{A_w}{A_z} = \frac{V_{bz}}{C_d \times \sqrt{2g\Delta H \frac{\Delta T}{T_{ref}}}} \times \sqrt{1 + R^2} \times \left(1 + \frac{1}{R}\right) \times \frac{1}{A_z} \times 100 \quad (J-12)$$

#### J4. CONTROL AND ACCESSIBILITY (MIXED-MODE VENTILATION)

Mixed-mode ventilation is a hybrid system used to maintain IAQ and internal thermal temperatures year-round using both natural and mechanical ventilation systems.

- a. Natural ventilation systems use natural forces such as wind and thermal buoyancy to ventilate and cool spaces.
- b. Mechanical ventilation systems use mechanical systems with fans to supply and exhaust air from a space, provide humidity control, and, if required, filter possible contaminants.

By preferentially using natural ventilation when outdoor air conditions are suitable, energy costs and carbon emissions can be minimized. Sensors are used to identify when natural ventilation is less effective at providing suitable indoor temperatures, humidity levels, and contaminant levels, and indicate that a transition to mechanical ventilation should occur. The transition between modes can be manual or automatic, as dictated by the needs of the owner/occupants. The use of each mode when appropriate will ensure year-round acceptable IAQ.

**(This appendix is not part of this standard. It is merely informative and does not contain requirements necessary for conformance to the standard. It has not been processed according to the ANSI requirements for a standard and may contain material that has not been subject to public review or a consensus process. Unresolved objections on informative material are not offered the right to appeal at ASHRAE or ANSI.)**

## **INFORMATIVE APPENDIX K COMPLIANCE**

This appendix contains compliance suggestions that are intended to assist users and enforcement agencies in applying this standard.

### **K1. SECTION 4**

- Is documentation of outdoor air quality included as required in Section 4.3?

### **K2. SECTION 5**

- Are air balancing provisions included in design documentation as required in Section 5.1?
- If the system is a plenum system, are provisions for providing minimum breathing zone airflow specified?
- Do exhaust ducts comply with requirements of Section 5.2?
- Are ventilation systems controls specified as per Section 5.3?
- Do specifications include resistance to mold and erosion for airstream surfaces per Section 5.4?
- Are separation distances between outdoor air intakes and sources listed and in compliance with Section 5.5?
- Is there any noncombustion equipment that requires exhaust (Section 5.6)?
- Is combustion air provided for fuel-burning appliances (Section 5.8)?
- Are appropriate filters specified upstream of cooling coils or wetted surfaces (Section 5.9)?
- Are dehumidification capability and building exfiltration calculations provided (Section 5.10)?
- Do specifications for drain pans comply with requirements of Section 5.12?
- Are coils specified per requirements of Section 5.13?
- If present, do humidifiers and water spray systems comply with requirements of Section 5.14?
- Is access provided for inspection, cleaning, and maintenance of all ventilation equipment and air distribution equipment (Section 5.15)?
- Is moisture management (Section 5.16) included in building envelope design, including specifically,
  - weather barrier;
  - vapor retarder;
  - sealing exterior joints, seams, and penetrations;
  - insulation on pipes, ducts, or other surfaces whose temperatures are expected to fall below dew point of surrounding air?
- If there is an attached parking garage? Do airflow control measures comply with requirements of Section 5.17?
- Is recirculation from spaces containing Class 2 air limited to spaces with the same purpose and with the same pollutants following requirements of Section 5.18.3.2?
- Is air from spaces containing Class 3 air contained and not transferred to any other space (Section 5.18.3.3)?
- Is all air from spaces containing Class 4 air exhausted directly to the outdoors (Section 5.18.3.4)?
- If environmental tobacco smoke is expected to be present, does the design comply with all separation requirements of Section 5.19?

### K3. SECTION 6 VRP

- Are occupancy categories consistent with the space design documents?
- Are there any unusual sources of contaminants or compounds? If yes, ventilation must be added per Section 6.3.6.

#### K3.1 Filtration

- If PM10 standard is exceeded as reported in Section 4, is required filtration per Section 6.1.4.1 provided?
- If PM2.5 standard is exceeded as reported in Section 4, is required filtration per Section 6.1.4.2 provided?
- If ozone standard is exceeded, and the area is Serious, Severe15, Severe17, or Extreme, filtration per Section 6.1.4.3 is required unless an exception is documented.

**K3.2 Ventilation Rates.** Check compliance with the outdoor air ventilation rate at the intake ( $V_{ot}$ ) using the following process.

- Calculate  $V_{otdefault}$  using Equation K-1 using the combined default rate ( $R_c$ ) from Informative Appendix L and the occupiable area ( $A_z$ ) of each zone.

$$V_{otdefault} = \sum_{all\ zones} R_c \times A_z \quad (K-1)$$

- Calculate additional ventilation required by Section 6.2.1.1.2. Additional ventilation is  $V_{otadditional}$ .

- Calculate  $V_{otmax}$  using Equation K-2.

$$V_{otmax} = V_{otdefault} + V_{otadditional} \quad (K-2)$$

- Calculate  $V_{otmin}$  using Equation K-3.

$$V_{otmin} = V_{otmax} \times 0.75 \quad (K-3)$$

- Designed system ventilation rate at the outdoor air intake ( $V_{ot}$ ) should fall between  $V_{otmin}$  and  $V_{otmax}$ .
- Values of  $V_{ot}$  for multiple-zone recirculating variable-air-volume (VAV) systems should be close to  $V_{otmax}$ .
- Values of  $V_{ot}$  for 100% (dedicated) outdoor air systems providing tempered air should be equivalent to  $V_{otmin}$ .
- Values of  $V_{ot}$  for other systems should fall between these values.
- If dynamic reset is included as a part of the design, does it comply with all requirements of Section 6.2.6?

#### Exceptions to K3.2:

1. Minimum outdoor airflow for multiple-zone recirculating systems designed using Normative Appendix A could be below  $V_{otmin}$ . A calculation spreadsheet should be provided to confirm that  $E_v$  for the system is greater than 0.75.
2. Minimum outdoor airflow for systems designed using Normative Appendix C could be below  $V_{otmin}$ . Calculation assumptions of any modeling criteria and results should be provided to confirm that  $E_z$  values are greater than 1.0.

### K4. SECTION 6 IAQP

For the IAQ procedure:

- Do the design documents provide evaluation of the following?
  - Compounds included in the design (Section 6.3.1)
    - List includes all contaminants of concern
  - Indoor sources and emissions rates for each compound
  - Outdoor sources and expected concentrations for each compound
  - Exposure periods and concentration limits
  - Evaluation of mixtures
  - Specification of perceived IAQ acceptability

- Calculation of resultant concentrations from the design by mass balance
- Do specifications include test methods?
- Do specifications require that the subjective evaluation process be completed during occupancy?
  - If a substantially similar zone is used for subjective evaluation, are previous test results, conditions, and system design provided to verify that the zone is substantially similar?
- If applicable, are appropriate specifications for dynamic reset monitoring and controls included?

#### **K5. SECTION 6 NATURAL VENTILATION PROCEDURE**

Natural ventilation systems shall follow either the prescriptive or the engineered system compliance path.

For the prescriptive compliance path:

- Is a mechanical system compliant with either Section 6.2 or 6.3 included?
  - If no, does design comply with Exceptions 1 or 2 of Section 6.4.1?
- Do maximum distances from openings comply with Sections 6.4.1.2, 6.4.1.3, or 6.4.1.4?
- Do opening sizes comply with the requirements of Section 6.4.2?
  - Is net free area of openings specified?
  - Are sill-to-head heights specified?
  - Are aggregate widths specified?
- Are controls readily accessible?

For the engineered compliance path:

- Do the design documents provide evaluation of the following:
  - Hourly environmental conditions, including, but not limited to, outdoor air dry-bulb temperature; dew-point temperature; outdoor concentration of contaminants of concern (including but not limited to PM2.5, PM10, and ozone), where data are available; wind speed and direction; and internal heat gains during expected hours of natural ventilation operation.
  - The effect of pressure losses along airflow paths of natural ventilation airflow on the resulting flow rates, including, but not limited to, inlet vents, air transfer grills, ventilation stacks, and outlet vents.
  - Qualification of natural ventilation airflow rates of identified airflow paths accounting for wind and thermally induced driving pressures.
  - Outdoor air is provided in sufficient quantities to ensure pollutants and odors of indoor origin do not result in unacceptable IAQ as established under Section 6.2.1.1 and/or 6.3.
  - Outdoor air introduced into the space through natural ventilation system openings does not result in unacceptable IAQ according to Sections 6.1.4.1 through 6.1.4.4.
  - Effective interior air barriers and insulation are provided that separate naturally ventilated spaces from mechanically cooled spaces, ensuring that high-dew-point outdoor air does not come into contact with mechanically cooled surfaces.
- Are controls readily accessible?

#### **K6. SECTION 6 EXHAUST**

Exhaust ventilation systems shall follow either the prescriptive or the performance compliance path.

For the prescriptive compliance path:

- Does airflow comply with requirements of Table 6-1 and 6-3?
  - If no for any space, does it qualify as an exception?
- Have source strengths been evaluated as required in Section 6.5.1.1?



For the performance compliance path:

- Do the design documents provide evaluation of the following?
  - Compounds of interest for the design
  - Indoor sources and emissions rates for each compound
  - Outdoor sources and emissions rates brought in by ventilation air
  - Exposure periods and concentration limits
  - Evaluation of mixtures
  - Calculation of resultant concentrations from the design
- Do specifications require that the subjective evaluation process be completed during occupancy (Section 6.3.4.2)?
- If applicable, are appropriate specifications for dynamic reset monitoring and controls included?

## K7. VENTILATION FOR EXISTING BUILDINGS

This section provides guidance for determining compliance with the standard for existing buildings. Many sustainability and energy programs require that ventilation rates for systems comply with ASHRAE Standard 62.1; however, the methods for determining compliance vary widely. This appendix is intended to provide a standardized approach and clear guidance for practitioners who work with existing buildings.

A ventilation system in an existing building may be deemed to comply with Standard 62.1 if the system complies with all the sections in this appendix. The building may be deemed to comply if all systems in the building comply with all the sections in this appendix (Sections K7.1, K7.2, and K7.3).

**K7.1 Filtration.** Filtration shall comply with Sections K7.1.1 and K7.1.2.

**K7.1.1 Filtration Before Coils.** Filtration complies with Section 5.9.

**K7.1.2 Filtration of Outdoor Air.** Filtration complies with Section 6.1.4.

**K7.2 Outdoor Airflow.** The following process may be used to determine if outdoor airflow rates comply with the standard. Occupied areas may be determined by measurement, dimensioned floor plans, or from building manager's data.

**K7.2.1 System Outdoor Airflow.** Measure system outdoor airflow. Measurements may be made directly or by installed flow measurement devices in the system that are calibrated. This rate is  $V_{otmeasured}$ .

**K7.2.2 Determine System Type.** Determine the system type and then follow the guidance in the appropriate section.

**K7.2.2.1 Single Zone Systems.** Determine  $V_{otdesign}$  using Section 6.2.3. If  $V_{otmeasured} \geq V_{otdesign}$ , the system complies.

**K7.2.2.2 100% Outdoor Air Systems.** Determine  $V_{otdesign}$  using Section 6.2.4. If  $V_{otmeasured} \geq V_{otdesign}$ , the system complies.

**K7.2.2.3 Multiple Zone Recirculating Systems.** Determine  $V_{otdesign}$  using any process listed in this section. If, in any calculation,  $V_{otmeasured} \geq V_{otdesign}$ , the system complies.

**Informative Note:** Calculations are ordered from simplest to most complex.

**K7.2.2.3.1 Appendix F.** Determine  $V_{otdesign}$  using Informative Appendix F.

**K7.2.2.3.1.1 Systems with Measured Zone Primary Airflow.** If measured zone primary airflow is available by VAV box readings or by a testing, adjusting, and balancing (TAB) report, one may calculate using either of the following approaches.

**K7.2.2.3.1.2 Simplified Procedure.** Determine  $V_{otdesign}$  using Section 6.2.4 simplified procedure.

**K7.2.2.3.1.3 Alternative Procedure.** Determine  $V_{otdesign}$  using Section 6.2.4 alternative procedure.

**Informative Note:** The alternative procedure provides credit for secondary recirculation.

**K7.3 Controls.** Confirm that ventilation system controls comply with requirements of Section 5.3.



(This appendix is not part of this standard. It is merely informative and does not contain requirements necessary for conformance to the standard. It has not been processed according to the ANSI requirements for a standard and may contain material that has not been subject to public review or a consensus process. Unresolved objectors on informative material are not offered the right to appeal at ASHRAE or ANSI.)

**INFORMATIVE APPENDIX L  
VENTILATION RATE CHECK TABLE**

Table L-1 is not for design purposes. It is intended to provide check values. Default rate per unit area is based on a multiple-zone system with default occupancy and default  $E_v$  that equals 0.75. This is the default  $E_v$  in the simplified rate when  $D > 0.60$ .

**Table L-1 Check Table for the Ventilation Rate Procedure**

Occupancy Category	Combined Outdoor Air Rate ( $R_c$ )	
	cfm/ft <sup>2</sup>	L/s · m <sup>2</sup>
<b>Animal Facilities</b>		
Animal exam room (veterinary office)	0.43	2.13
Animal imaging (MRI/CT/PET)	0.51	2.53
Animal operating rooms	0.51	2.53
Animal postoperative recovery room	0.51	2.53
Animal preparation rooms	0.51	2.53
Animal procedure room	0.51	2.53
Animal surgery scrub	0.51	2.53
Large-animal holding room	0.51	2.53
Necropsy	0.51	2.53
Small-animal-cage room (static cages)	0.51	2.53
Small-animal-cage room (ventilated cages)	0.51	2.53
<b>Correctional Facilities</b>		
Booking/waiting	0.58	2.93
Cell	0.33	1.63
Dayroom	0.28	1.40
Guard stations	0.18	0.90
<b>Educational Facilities</b>		
Art classroom	0.51	2.53
Classrooms (ages 5 through 8)	0.49	2.47
Classrooms (ages 9 plus)	0.63	3.13
Computer lab	0.49	2.47
Daycare sickroom	0.57	2.87
Daycare (through age 4)	0.57	2.87
Lecture classroom	0.73	3.69
Lecture hall (fixed seats)	1.58	8.00
Libraries	0.23	1.13
Media center	0.49	2.47

**Table L-1 Check Table for the Ventilation Rate Procedure (Continued)**

Occupancy Category	Combined Outdoor Air Rate ( $R_c$ )	
	cfm/ft <sup>2</sup>	L/s · m <sup>2</sup>
Multiuse assembly	1.08	5.47
Music/theater/dance	0.55	2.73
Science laboratories	0.57	2.87
University/college laboratories	0.57	2.87
Wood/metal shop	0.51	2.53
<b>Food and Beverage Service</b>		
Bars, cocktail lounges	1.24	6.27
Cafeteria/fast-food dining	1.24	6.27
Kitchen (cooking)	0.36	1.81
Restaurant dining rooms	0.94	4.75
<b>Food and Beverage Service, General</b>		
Break rooms	0.25	1.23
Coffee stations	0.21	1.07
Conference/meeting	0.41	2.07
Corridors	0.08	0.40
Occupiable storage rooms for liquids or gels	0.17	0.87
<b>Hotels, Motels, Resorts, Dormitories</b>		
Barracks sleeping areas	0.21	1.07
Bedroom/living room	0.15	0.73
Laundry rooms (central)	0.23	1.13
Laundry rooms within dwelling units	0.23	1.13
Lobbies/prefunction	0.38	1.92
Multipurpose assembly	0.88	4.40
<b>Miscellaneous Spaces</b>		
Banks or bank lobbies	0.23	1.16
Bank vaults/safe deposit	0.11	0.57
Computer (not printing)	0.11	0.53
Freezer and refrigerated spaces (<50°F [10°C])	0.03	0.13
General manufacturing (excludes heavy industrial and processes using chemicals)	0.33	1.67
Pharmacy (prep area)	0.31	1.53
Photo studios	0.23	1.13
Shipping/receiving	0.19	0.93
Sorting, packing, light assembly	0.23	1.15
Telephone closets	0.00	0.00
Transportation waiting	1.08	5.47
Warehouses	0.09	0.47

**Table L-1 Check Table for the Ventilation Rate Procedure (Continued)**

Occupancy Category	Combined Outdoor Air Rate ( $R_c$ )	
	cfm/ft <sup>2</sup>	L/s·m <sup>2</sup>
<b>Office Buildings</b>		
Breakrooms	0.49	2.47
Main entry lobbies	0.15	0.73
Occupiable storage rooms for dry materials	0.09	0.47
Office space	0.11	0.57
Reception areas	0.28	1.40
Telephone/data entry	0.48	2.40
<b>Outpatient Health Care Facilities</b>		
Birthing room	0.44	2.20
Class 1 imaging rooms	0.19	0.97
Dental operatory	0.51	2.53
General examination room	0.36	1.81
Other dental treatment areas	0.11	0.57
Physical therapy exercise area	0.43	2.13
Physical therapy individual room	0.35	1.73
Physical therapeutic pool area	0.64	3.20
Prosthetics and orthotics room	0.51	2.53
Psychiatric consultation room	0.21	1.07
Psychiatric examination room	0.21	1.07
Psychiatric group room	0.41	2.07
Psychiatric seclusion room	0.15	0.73
Urgent care examination room	0.36	1.81
Urgent care observation room	0.21	1.07
Urgent care treatment room	0.44	2.21
Urgent care triage room	0.51	2.53
Speech therapy room	0.21	1.07
<b>Public Assembly Spaces</b>		
Auditorium seating area	1.08	5.40
Courtrooms	0.55	2.73
Legislative chambers	0.41	2.07
Libraries	0.23	1.13
Lobbies	1.08	5.40
Museums (children's)	0.56	2.83
Museums/galleries	0.48	2.43
Places of religious worship	0.88	4.40

**Table L-1 Check Table for the Ventilation Rate Procedure (Continued)**

Occupancy Category	Combined Outdoor Air Rate ( $R_c$ )	
	cfm/ft <sup>2</sup>	L/s·m <sup>2</sup>
<b>Retail</b>		
Sales (except as below)	0.31	1.56
Barbershop	0.33	1.67
Beauty and nail salons	0.83	4.13
Coin-operated laundries	0.36	1.81
Mall common areas	0.48	2.43
Pet shops (animal areas)	0.34	1.71
Supermarket	0.16	0.81
<b>Sports and Entertainment</b>		
Bowling alley (seating)	0.69	3.47
Disco/dance floors	2.75	13.73
Gambling casinos	1.44	7.28
Game arcades	0.44	2.21
Gym, sports arena (play area)	0.43	2.13
Health club/aerobics room	1.15	5.73
Health club/weight rooms	0.35	1.73
Spectator areas	1.58	8.00
Stages, studios	1.01	5.07
Swimming (pool and deck)	0.64	3.20
<b>Transient Residential</b>		
Dwelling unit	0.10	0.50

**(This appendix is not part of this standard. It is merely informative and does not contain requirements necessary for conformance to the standard. It has not been processed according to the ANSI requirements for a standard and may contain material that has not been subject to public review or a consensus process. Unresolved objectors on informative material are not offered the right to appeal at ASHRAE or ANSI.)**

**INFORMATIVE APPENDIX M  
INFORMATIVE REFERENCES**

Reference	Title	Section
<b>Air Movement and Control Association International (AMCA)</b> 30 W University Dr. Arlington Heights, IL 60004 (847) 394-0150; <a href="http://www.amca.org">www.amca.org</a>		
AMCA 511 (Rev. 2016)	Certified Ratings Program—Product Rating Manual for Air Control Devices	5.5.2
<b>ASHRAE</b> 1791 Tullie Circle NE Atlanta, GA 30329 (800) 527-4723; <a href="http://www.ashrae.org">www.ashrae.org</a>		
	2017 ASHRAE Handbook—Fundamentals	Appendix J
ASHRAE RP-1009 (2001)	Simplified Diffuser Boundary Conditions for Numerical Room Airflow Models	Appendix C
ASHRAE RP-1373 (2009)	Air Distribution Effectiveness with Stratified Air Distribution Systems	Appendix C
ASHRAE Standard 55 (2017)	Thermal Environmental Conditions for Human Occupancy	G1.2.7
<b>Chartered Institution of Building Services Engineers (CIBSE)</b> 222 Balham High Road London SW12 9BS United Kingdom +44 (0)20 8675 5211; <a href="http://www.cibse.org">www.cibse.org</a>		
CIBSE AM10 (2005)	Natural Ventilation in Non-Domestic Buildings	Appendix J
<b>Wiley &amp; Sons</b>		
Etheridge, D.W., and M. Sandberg (1996)	Building Ventilation: Theory and Measurement, Vol. 50	Appendix J
<i>Energy and Buildings</i> 65:516–22		
von Grabe, J. (2013)	Flow resistance for different types of windows in the case of buoyancy ventilation	Appendix J
<i>International Journal of Environmental Research and Public Health</i> 11(11):11753-71.		
Ahn, J.H., J.E. Szulejko, K.H. Kim, Y.H. Kim, and B.W. Kim (2014)	Odor and VOC emissions from pan frying of mackerel at three stages: Raw, well-done, and charred	Appendix N
<b>National Institute of Standards and Technology (NIST)</b> 100 Bureau Dr., Gaithersburg, MD 20899 (301) 975-2000; <a href="http://www.nist.gov">www.nist.gov</a>		
Dols, W.S., and G.N. Walton (2002)	CONTAMW 2.0 User Manual	Appendix E

(This appendix is not part of this standard. It is merely informative and does not contain requirements necessary for conformance to the standard. It has not been processed according to the ANSI requirements for a standard and may contain material that has not been subject to public review or a consensus process. Unresolved objections on informative material are not offered the right to appeal at ASHRAE or ANSI.)

## INFORMATIVE APPENDIX N INDOOR AIR QUALITY PROCEDURE (IAQP)

### N1. SUMMARY OF SELECTED AIR QUALITY GUIDELINES

If the Indoor Air Quality Procedure (IAQP) is used, acceptable indoor concentrations limits are needed for design compounds (DCs) and particles. When using this procedure, these concentration limits need to be referenced from a cognizant authority as defined in the standard. At present, no single organization develops acceptable concentrations limits for all substances in indoor air, nor are limits available for all potential DCs or particles.

Cognizant authorities, such as USEPA, California EPA, and the Committee for Health Related Evaluation of Building Products (AgBB) publish concentration limits for compounds, many of which may be present in the indoor environment. Compounds included in the IAQP design need to be included if data were judged sufficient to indicate a compound was likely to be found in buildings at concentrations that were a substantial fraction of the proposed design target (DT). The goal is not to include every possible compound that may appear in indoor air, but rather sufficient numbers of compounds, and diversity thereof, such that control of the compounds is anticipated to result in air quality that meets the standard's definition of "acceptable."

A summary of considerations is presented below:

- a. Is a compound expected to be present in indoor air with reasonable frequency at concentrations relevant to (but not necessarily above) the DT? Specifically, the design outdoor air flow rate ( $V_{oz}$ ) and design features will be controlled by the compounds with the highest emission rates and lowest targets (taking mixtures into account); thus, compounds with low concentrations and high targets will have little or no impact on the calculated  $V_{oz}$ .
- b. Is there a DT that has been proposed by a cognizant authority?
- c. Does it seem reasonable to expect that product emissions rates may be available for the proposed compound?
- d. Is there an established sampling and analytical method for the proposed compound?

Occupational exposure limits (e.g., permissible exposure limits and threshold limit values) are not appropriate as DTs, as they are not established for acceptable indoor air quality or for typical commercial buildings. In general, they were developed for industrial applications evaluating effects of substances on healthy adult male workers.

### N2. GUIDELINE FOR EMISSION RATES

Several published peer-reviewed papers provide a reference for design teams to use to compile reasonable DC emission rates. A nonexhaustive list of peer-reviewed papers is shown in Section N4. In addition, there are multiple established certification programs that include empirical measures of emission rates for construction materials as well as finishes, furniture and equipment intended for indoor use. These include third-party programs as well as industry trade association programs and programs in support of government regulations (e.g., the AgBB evaluation scheme used in Germany and parts of Europe, Blue Angel, BIFMA, Green Label, France A+, CDPH Standard Method for testing and evaluation of VOC emissions [CDPH Section 01350], Greenguard, SCS Indoor Advantage Gold, and Floorscore). Engineers may use the emission rates for the specific materials that a designer is including or considering for use. The IAQP (Section 6.3) requires that emission rates must consider DCs emitted by occupants and their activities, by materials, and by specific sources within the occupied spaces and introduced into the building with outdoor air.

### N3. SUBJECTIVE EVALUATION

Section 6.3.4.2 requires that an occupant survey be conducted. Many subjective evaluation approaches have been used with varying degrees of success. The following is an example of an evaluation approach that focuses on adapted occupants:

- a. After the building is completed and substantially occupied, provide all occupants with an electronic or written survey questions, including, “Do you perceive the air quality in your environment to be acceptable or unacceptable?”
- b. Anonymous surveys with neutrally framed questions provide the best responses.
- c. When conducting an evaluation of adapted occupants, respondents must record their perception of zone air quality after 30 minutes residency in the occupied zone.
- d. All occupants should be surveyed, if possible. Otherwise, at least 50% of typical occupancy, or 300, whichever is less, should be randomly selected.
- e. A minimum 30% response rate from those surveyed is desirable. Each zone must be surveyed per requirements of Section 6.3. The subjective evaluation validates the acceptability of indoor air if 80% of respondents in the area do not express dissatisfaction. The Center for the Built Environment at UC Berkeley has developed a survey that includes IAQ questions and may be a useful template.

#### N4. BIBLIOGRAPHY

- Ahn, J.H., J.E. Szulejko, K.H. Kim, Y.H. Kim, and B.W. Kim. 2014. Odor and VOC emissions from pan frying of mackerel at three stages: Raw, well-done, and charred. *International Journal of Environmental Research and Public Health* 11(11):11753–71.
- Apte, M.G. 2013. Final Report: Balancing energy conservation and occupant needs in ventilation rate standards for Big Box stores in California: Predicted indoor air quality and energy consumption using a matrix of ventilation scenarios. LBNL Paper LBNL-5551E, Lawrence Berkeley National Laboratory, University of California, Berkeley.
- Assadi, A.A., J. Palau, A. Bouzaza, J. Penya-Roja, V. Martinez-Soriac, and D. Wolbert. 2014. Abatement of 3-methylbutanal and trimethylamine with combined plasma and photocatalysis in a continuous planar reactor. *Journal of Photochemistry and Photobiology A: Chemistry* 282:1–8.
- Barro, R., J. Regueiro, M. Llompert, C. Garcia-Jares. 2009. Analysis of industrial contaminants in indoor air: Part 1. Volatile organic compounds, carbonyl compounds, polycyclic aromatic hydrocarbons and polychlorinated biphenyls. *Journal of Chromatography A* 1216(3):540–66.
- Batterman, S, F.C. Su, S. Li, B. Mukherjee, and C. Jia. 2014. Personal exposure to mixtures of volatile organic compounds: modeling and further analysis of the RIOPA data. Research report (Health Effects Institute). 181:3–63.
- Bi, X.H., G.Y. Sheng, Y.L. Feng, J.M. Fu, and J.X. Xie. 2005. Gas- and particulate-phase specific tracer and toxic organic compounds in environmental tobacco smoke. *Chemosphere* 61(10):1512–22.
- Boraphech, P., and P. Thiravetyan. 2015. Removal of trimethylamine (fishy odor) by C-3 and CAM plants. *Environmental Science and Pollution Research* 22(15):11543–57.
- Bradman, A., F. Gaspar, R. Castorina, J. Williams, T. Hoang, and P.L. Jenkins. 2017. Supporting Information: Formaldehyde and acetaldehyde exposure and risk characterization in California early childhood education environments. *Indoor Air* 27(1):104–113.
- CDPH. 2006. Long-term building air measurements for volatile organic compounds including aldehydes at a California five-building sustainable office complex, (Vol. 1/2 and 2/2). Report #CA/DHS/EHLB/R-172. California Department of Public Health, Sacramento, CA.
- Chan, W.R., S. Cohn, M. Sidheswaran, D.P. Sullivan, and W.J. Fisk. 2015. Contaminant levels, source strengths, and ventilation rates in California retail stores. *Indoor Air* 25(4):381–92.
- Choo, C.P., and J. Jalaludin. 2015. An overview of indoor air quality and its impact on respiratory health among Malaysian school-aged children. *Reviews on Environmental Health* 30(1):9–18.
- Claeson, A.S., M. Sandstrom, A.L. Sunesson. 2007. Volatile organic compounds (VOCs) emitted from materials collected from buildings affected by microorganisms. *Journal of Environmental Monitoring* 9(3):240–5.
- Cometto-Muniz, J.E., and M.H. Abraham. 2015. Compilation and analysis of types and concentrations of airborne chemicals measured in various indoor and outdoor human environments. *Chemosphere* 127:70–86.
- Cometto-Muniz, J.E., and W.S. Cain. 1992. Sensory irritation. Relation to indoor air pollution. *Annals of the New York Academy of Sciences* 641:137–51.

- Dodson, R.E., J.I. Levy, E.A. Houseman, J.D. Spengler, and D.H. Bennett. 2009. Evaluating methods for predicting indoor residential volatile organic compound concentration distributions. *Journal of Exposure Science and Environmental Epidemiology* 19(7):682–93.
- Dutton, S.M. 2014. Evaluation of the indoor air quality procedure for use in retail buildings. LBNL Paper LBNL-6079E, Lawrence Berkeley National Laboratory, University of California, Berkeley, CA.
- Fenske, J.D., and S.E. Paulson. 1999. Human breath emissions of VOCs. *Journal of the Air and Waste Management Association* 49(5):594–8.
- Fischer, M.L., D. Littlejohn, M.M. Lunden, N.J. Brown. 2003. Automated measurements of ammonia and nitric acid in indoor and outdoor air. *Environmental Science and Technology* 37(10):2114–9.
- Godwin, C, and S. Batterman. 2007. Indoor air quality in Michigan schools. *Indoor Air* 17(2):109–21.
- Harrison, R.M., J.M. Delgado-Saborit, S.J. Baker, N. Aquilina, C. Meddings, and S. Harrad. 2009. Measurement and modeling of exposure to selected air toxics for health effects studies and verification by biomarkers. Research report (Health Effects Institute) 143:3-96, Discussion 7–100.
- Hau, K.M., D.W. Connell, and B.J. Richardson. 2000. Use of partition models in setting health guidelines for volatile organic compounds. *Regulatory Toxicology and Pharmacology* 31(1):22–9.
- Hau, K.M., D.W. Connell, and B.J. Richardson. 2000. Use of partition models to evaluate guidelines for mixtures of volatile organic compounds. *Regulatory Toxicology and Pharmacology* 32(1):36–41.
- Hodgson, A.T., and H. Levin. 2003. Volatile organic compounds in indoor air: A review of concentrations measured in North America since 1990. Report No. LBNL-51715, Lawrence Berkeley National Laboratory, Berkeley, CA.
- Hotchi, T., A.T. Hodgson, and W.J. Fisk. 2006. Indoor air quality impacts of a peak load shedding strategy for a large retail building. LBL Contract No. 500-03-026, PIER Demand Response Research Center, Lawrence Berkeley National Laboratory, Berkeley, CA.
- Ilacqua, V., O. Hänninen, N. Kuenzli, and M.F. Jantunen. 2007. Intake fraction distributions for indoor VOC sources in five European cities. *Indoor Air* 17(5):372–83.
- Kinney, P.L., S.N. Chillrud, S. Ramstrom, J. Ross, and J.D. Spengler. 2002. Exposures to multiple air toxics in New York City. *Environmental Health Perspectives* 110:539–46.
- Lamorena, R.B., and W. Lee. 2008. Influence of ozone concentration and temperature on ultra-fine particle and gaseous volatile organic compound formations generated during the ozone-initiated reactions with emitted terpenes from a car air freshener. *Journal of Hazardous Materials* 158(2-3):471–7.
- Lee, S.C., S. Lam, and H.K. Fai. 2001. Characterization of VOCs, ozone, and PM10 emissions from office equipment in an environmental chamber. *Building and Environment* 36(7):837–42.
- Lindgren, T. 2010. A case of indoor air pollution of ammonia emitted from concrete in a newly built office in Beijing. *Building and Environment* 45(3):596–600.
- Lioy, P.J., Z. Fan, J. Zhang, P. Georgopoulos, S.W. Wang, and P. Ohman-Strickland. 2011. Personal and ambient exposures to air toxics in Camden, New Jersey. Research report (Health Effects Institute) (160):3–127, Discussion 9–51.
- Liu W, Zhang J, Zhang L, Turpin BJ, Weisel CP, Morandi MT, et al. Estimating contributions of indoor and outdoor sources to indoor carbonyl concentrations in three urban areas of the United States. *Atmospheric Environment*. 2006;40(12):2202-14.
- Nagda, N.L., and H.E. Rector. 2003. A critical review of reported air concentrations of organic compounds in aircraft cabins. *Indoor Air* 13(3):292–301.
- Nazaroff, W.W., and C.J. Weschler. 2004. Cleaning products and air fresheners: exposure to primary and secondary air pollutants. *Atmospheric Environment* 38(18):2841–65.
- Norback, D., and G. Wieslander. 2002. Biomarkers and chemosensory irritations. *International Archives Of Occupational And Environmental Health* 75(5):298–304.
- Ohura, T., T. Amagai, X. Shen, S. Li, P. Zhang, and L. Zhu. 2009. Comparative study on indoor air quality in Japan and China: Characteristics of residential indoor and outdoor VOCs. *Atmospheric Environment* 43(40):6352–9.



- Oikawa, D., W. Takeuchi, S. Murata, K. Takahashi, and Y. Sekine. 2012. Measurement of concentrations of thioglycolic acid, dithiodiglycolic acid and ammonia in indoor air of a beauty salon. *Journal of Occupational Health*. 54(5):370–5.
- Pant, P., S.K. Guttikunda, and R.E. Peltier. 2016. Exposure to particulate matter in India: A synthesis of findings and future directions. *Environmental Research* 147:480–96.
- Park, J.S., and K. Ikeda. 2006. Variations of formaldehyde and VOC levels during 3 years in new and older homes. *Indoor Air* 16(2):129–35.
- Repache, J.L., J.N. Hyde, and D. Brugge. 2006. Air pollution in Boston bars before and after a smoking ban. *BMC Public Health* 6:266.
- Roda, C., I. Kousignian, C. Guihenneuc-Jouyaux, C. Dassonville, I. Nicolis, and J. Just. 2011. Formaldehyde exposure and lower respiratory infections in infants: Findings from the PARIS cohort study. *Environmental Health Perspectives*. 119(11):1653–8.
- Rohr, A.C. 2013. The health significance of gas- and particle-phase terpene oxidation products: a review. *Environment international*. 60:145-62.
- Saha, C.K., G.Q. Zhang, P. Kai, and B. Bjerg. 2010. Effects of a partial pit ventilation system on indoor air quality and ammonia emission from a fattening pig room. *Biosystems Engineering* 105(3):279–87.
- Salonen, H.J., A.L. Pasanen, S.K. Lappalainen, H.M. Riuttala, T.M. Tuomi, and P.O. Pasanen. 2009. Airborne concentrations of volatile organic compounds, formaldehyde and ammonia in Finnish office buildings with suspected indoor air problems. *Journal of Occupational and Environmental Hygiene* 6(3):200–9.
- Santarsiero, A., S. Fuselli, A. Piermattei, R. Morlino, G. De Blasio, and M. De Felice. 2009. Investigation of indoor air volatile organic compounds concentration levels in dental settings and some related methodological issues. *Annali dell'Istituto superiore di sanita* 45(1):87–98.
- Sarigiannis, D.A., S.P. Karakitsios, A. Gotti, I.L. Liakos, and A. Katsoyiannis. 2011. Exposure to major volatile organic compounds and carbonyls in European indoor environments and associated health risk. *Environment International* 37(4):743–65.
- Sax, S.N., D.H. Bennett, S.N. Chillrud, P.L. Kinney, and J.D. Spengler. 2004. Differences in source emission rates of volatile organic compounds in inner-city residences of New York City and Los Angeles. *Journal of Exposure Analysis and Environmental Epidemiology* 14:S95–S109.
- Schripp, T., S. Langer, and T. Salthammer. 2012. Interaction of ozone with wooden building products, treated wood samples and exotic wood species. *Atmospheric Environment* 54:365–72.
- Siegel, J.A., J. Srebric, N. Crain, E. Nirlo, M. Zaatari, and A. Hoisington. 2012. Ventilation and indoor air quality in retail stores (RP-1596). *HVAC&R Research* 20(2).
- Smith, T.J., M.E. Davis, J.E. Hart, A. Blicharz, F. Laden, and E. Garshick. 2012. Potential air toxics hot spots in truck terminals and cabs. Research report (Health Effects Institute) (172):5–82.
- Tham, K.W., M.S. Zuraimi, and S.C. Sekhar. 2004. Emission modelling and validation of VOCs' source strengths in air-conditioned office premises. *Environment International*. 30(8):1075–88.
- Vainiotalo, S., V. Vaananen, and R. Vaaranrinta. 2008. Measurement of 16 volatile organic compounds in restaurant air contaminated with environmental tobacco smoke. *Environmental Research* 108(3):280–8.
- Wang, S., H.M. Ang, and M.O. Tade. 2007. Volatile organic compounds in indoor environment and photocatalytic oxidation: state of the art. *Environment International* 33(5):694–705.
- Wang, T.C. 1975. A study of bioeffluents in a college classroom. *ASHRAE transactions* 81(1):1–12.
- Weisel, C.P. 2002. Assessing exposure to air toxics relative to asthma. *Environmental Health Perspectives* 110 Suppl. 4:527–37.
- Winkle, M.R., and P.A. Scheff. 2001. Volatile organic compounds, polycyclic aromatic hydrocarbons and elements in the air of ten urban homes. *Indoor Air* 11(1):49–64.
- Wolkoff, P. 2013. Indoor air pollutants in office environments: Assessment of comfort, health, and performance. *International Journal of Hygiene and Environmental Health* 216(4):371–94.

- Wolkoff, P., C.K. Wilkins, P.A. Clausen, and G.D. Nielsen. 2006. Organic compounds in office environments—Sensory irritation, odor, measurements and the role of reactive chemistry. *Indoor Air* 16(1):7–19.
- Wu, X.M., M.G. Apte, R. Maddalena, and D.H. Bennett. 2011. Volatile organic compounds in small- and medium-sized commercial buildings in California. *Environmental Science and Technology* 45(20):9075–83.
- Zaatari, M., and J. Siegel. 2014. Particle characterization in retail environments: Concentrations, sources, and removal mechanisms. *Indoor Air* 24(4):350–61.
- Zhu, J., R. Newhook, L. Marro, and C.C. Chan. 2005. Selected volatile organic compounds in residential air in the city of Ottawa, Canada. *Environmental Science and Technology* 39(11):3964–71.

(This appendix is not part of this standard. It is merely informative and does not contain requirements necessary for conformance to the standard. It has not been processed according to the ANSI requirements for a standard and may contain material that has not been subject to public review or a consensus process. Unresolved objections on informative material are not offered the right to appeal at ASHRAE or ANSI.)

**INFORMATIVE APPENDIX O  
ADDENDA DESCRIPTION INFORMATION**

ANSI/ASHRAE Standard 62.1-2019 incorporates ANSI/ASHRAE Standard 62.1-2016 and Addenda b, c, d, e, f, g, h, i, j, k, l, m, n, o, p, r, s, t, u, v, w, z, ad, ae, af, ah, aj, al, am, an, ap, aq, ar, and as to ANSI/ASHRAE Standard 62.1-2016. Table O-1 lists each addendum and describes the way in which the standard is affected by the change. It also lists the ASHRAE and ANSI approval dates for each addendum.

**Informative:** Many sections and appendices have been renumbered in the 2019 edition. The designations listed below reflect those prior to reorganization. Final designations may differ. Please refer to the [Table of Contents](#).

**Table O-1 Addenda to ANSI/ASHRAE Standard 62.1-2016**

Addendum	Section(s) Affected	Description of Changes*	Approval Dates: • Standards Committee • ASHRAE BOD/ Tech Council • ANSI
b	(NEW) Informative Appendix D	Addendum b adds a new Informative Appendix D, which includes a simplified ventilation rate table for use in existing buildings where information for calculating minimum ventilation using Normative Appendix A for multiple spaces is often unavailable.	September 14, 2018 September 28, 2018 October 1, 2018
c	6.3.1, 6.3.2, 6.3.4.2, 6.5.2.1, 6.5.2.2; (DELETED) Informative Appendix C	Addendum c deletes Informative Appendix C, “Summary of Selected Air Quality Guidelines,” from Standard 62.1.	June 23, 2018 June 27, 2018 July 25, 2018
d	(DELETED) Informative Appendix D	Addendum d deletes Informative Appendix D, “Rationale for Minimum Physiological Requirements for Respiration Air Based on CO <sub>2</sub> Concentration.”	January 20, 2018 January 24, 2018 February 21, 2018
e	4.4.1; 6.2.1.3; Informative Appendix F; (DELETED) Informative Appendix I	Addendum e modifies Informative Appendix F, “Information on Selected National Standards and Guidelines for PM <sub>10</sub> , PM <sub>2.5</sub> , And Ozone,” and deletes Informative Appendix I, “National Ambient Air Quality Standards (NAAQS)”. There is no current map for when the most recent three-year average annual fourth-highest daily maximum eight-hour average ozone concentration exceeds 0.107 ppm. Therefore, the map and reference to it are deleted by this addendum.	January 20, 2018 January 24, 2018 January 25, 2018

\* These descriptions may not be complete and are provided for information only.

Table O-1 Addenda to ANSI/ASHRAE Standard 62.1-2016

Addendum	Section(s) Affected	Description of Changes*	Approval Dates:
f	3; 6.2.5; Normative Appendix A	Addendum g replaces the Table 6.2.5.2 approach with two formulas, one to determine system ventilation efficiency and one to determine the minimum primary airflow set point intended for use in VAV systems.	June 23, 2018 June 27, 2018 June 28, 2018
g	3	The current wording exempts “spaces that are intended primarily for other purposes,” but this could be interpreted as requiring ventilation for spaces that are seldom occupied, such as exit stairways and passageways, which are seldom ventilated in standard practice. The key clause with respect to ventilation is whether spaces are “occupied occasionally and for short periods of time.” This change makes that clear and adds the example of emergency exit passageways to make that application specifically exempt.	June 23, 2018 June 27, 2018 June 28, 2018
h	Informative Appendix G	Addendum h modifies Informative Appendix G to add informative text that is contained in the current scope.	June 23, 2018 June 27, 2018 June 28, 2018
i	2; 3	This addendum removes informative text that is not part of the definition of scope and clarifies when the standard does not provide ventilation rates. A companion Addendum h adds informative text to Informative Appendix G, “Application.”	June 22, 2019 June 26, 2019 July 24, 2019
j	4	Section 4 refers to information from USEPA. This information is subject to change, so Addendum j updates the informative notes in this section.	June 23, 2018 June 27, 2018 June 28, 2018
k	6.2.1.3	Standard 62.1-2016 contains requirements for filtration of ozone from outdoor air under certain conditions. This addendum changes the requirement to be consistent with current EPA ambient air quality standards.	September 14, 2018 September 28, 2018 October 1, 2018

\* These descriptions may not be complete and are provided for information only.

**Table O-1 Addenda to ANSI/ASHRAE Standard 62.1-2016**

Addendum	Section(s) Affected	Description of Changes*	Approval Dates:
l	3; 6.1.3, 6.4, 6.6	<p>This addendum provides specific requirements for the exception to the natural ventilation procedure by providing a clear compliance path. It also recognizes that there are inherent health issues with outdoor air in many locations in the world and updates the prescriptive requirements based on recent studies and airflow evaluations.</p> <p>Outdoor Air requirements specified in 6.2.1 have been applied to naturally ventilated buildings</p> <p>The prescriptive path has been improved by removing the openable area requirement of 4% of net occupiable floor area and introducing two prescriptive paths for sizing the required openable area that better respond to program in the zone and window type.</p> <p>A four-point definition of a naturally ventilated engineered system has been developed to require designers to more fully document natural ventilation systems that do not meet prescriptive values.</p>	<p>July 22, 2019                      August 1, 2019                      August 26, 2019</p>
m	5.8; 6.2.1.1, 6.2.1.2; 9	<p>The current standard contains requirements for filtration of particles from outdoor air under certain conditions. It also requires filtration upstream of wetted surfaces. Addendum m adds ISO ratings as an option to the existing MERV requirements and makes some modifications for consistency.</p>	<p>January 12, 2019                      January 16, 2019                      February 13, 2019</p>
n	Table 6.2.2.1, (NEW) 6.2.2.1.1.3	<p>Addendum n adds requirements for animal facilities. Ammonia is added to compounds of common interest in a different addenda.</p>	<p>June 22, 2019                      June 26, 2019                      July 24, 2019</p>
o	5.16.2.1	<p>The current standard contains requirements for redesignation that are based on informative text. This addendum clarifies and refers to mandatory requirements for Classes 3 and 4 air.</p>	<p>June 23, 2018                      June 27, 2018                      July 25, 2018</p>

\* These descriptions may not be complete and are provided for information only.

Table O-1 Addenda to ANSI/ASHRAE Standard 62.1-2016

Addendum	Section(s) Affected	Description of Changes*	Approval Dates:
q	5.1.1, 5.3.2, 7.2.2	<p>Section 5 and 7 changes are intended to better satisfy the objectives of the requirements already included in the standard and improve the language describing them. The changes differentiate the objectives fostering anticipation for the needs of system measurements with appropriate designs and those of airflow verification.</p> <p>Section 5.1.1 solicits design attention for duct layout conditions and anything that contributes to making field measurement difficult, prone to high error rates, or sometimes impossible to perform. The new language in Section 5.3.2 is intended to provide a generalized and simpler statement of this requirement's objective and avoid the expression of limited alternatives in subsection items (a) through (c), yet provide designers and building owners the same flexibility and design choices.</p> <p>Modification of 7.2.2 addresses the operational requirements reflected elsewhere in the standard. "Under any load or dynamic reset condition" must also be considered when verifying the capability of the ventilation system to function as required, particularly at the point of operation where minimum outdoor air control is the most difficult. The new requirement identifies that direct measurement is the only method allowed to verify intake flow rates.</p>	<p>June 23, 2018 June 27, 2018 July 25, 2018</p>
r	5.5.1, Table 5.5.1, 5.14.2, 5.16.1, Table 5.16.1, "Airstream or Surfaces" moved to Table 6.5.2, "Airstream or Sources"	<p>Addendum r makes several changes to Section 5. For outdoor air intakes, the alternate methods of calculation are specified in Normative Appendix B, and the exception is eliminated. Requirements in the Table 5.5.1 footnotes are relocated to the body of the standard. If condensation is to be managed (Exception 5.14.2), then a management plan must be developed. If "local practice" demonstrates condensation does not grow mold, it can be included in the management plan. Table 5.16.1, "Airstreams or Sources," is relocated to Section 6 where all other air class information resides.</p>	<p>June 23, 2018 June 27, 2018 July 25, 2018</p>
s	3; 6.1.1, 6.2.2.1, (NEW) 6.2.5.1.3, 6.2.7.1, Table 6.2.2.1	<p>The ventilation rate procedure in Standard 62.1-2016 contains requirements in notes. This addendum relocates requirements to the body of the standard. Another change clarifies that in the presence of unusual sources, the rates in the VRP must be supplemented by additional ventilation to be determined by the IAQ procedure or an EHS professional. The default values per person in Table 6.2.2.1, "Minimum Ventilation Rates in Breathing Zone," do not contain any adjustments for Ev and, in many cases, are taken out of context. They are not used in the ventilation calculations. These values are deleted.</p>	<p>June 22, 2019 June 26, 2019 July 24, 2019</p>
t	(NEW) Informative Appendix L	<p>Addendum t adds a new informative appendix that is a companion to the changes to the Natural Ventilation Procedure. It provides information for application of the new procedure.</p>	<p>January 12, 2019 January 16, 2019 January 17, 2019</p>

\* These descriptions may not be complete and are provided for information only.

**Table O-1 Addenda to ANSI/ASHRAE Standard 62.1-2016**

Addendum	Section(s) Affected	Description of Changes*	Approval Dates:
u	(NEW) Informative Appendix M	This addendum adds a new informative appendix that provides a compliance checklist and simple calculations to approximately check ventilation rate values. Other standards have more complex compliance documents.	June 23, 2018 June 27, 2018 July 25, 2018
v	Normative Appendix B	This addendum adds requirements for alternate calculation methods (current Section B2[c]) but does not describe or prescribe a method.	June 23, 2018 June 27, 2018 July 25, 2018
w	5.5.1.4; 6.2.2.1.1.2; 6.5.1	Standard 62.1 contains minimum requirements for laboratories, but more complex laboratories should be designed with the different approach contained in ANSI Z9.5, "Laboratory Ventilation." This addendum recognizes that approach as valid in complying with the ventilation and exhaust requirements of Standard 62.1.	June 23, 2018 June 27, 2018 June 28, 2018
z	(NEW) Informative Appendix N	The default values per person in Table 6.2.2.1 do not contain adjustments for system ventilation efficiency and, in many cases, are taken out of context. These values are deleted in Addendum s. Addendum z provides an informative table with a rate per unit area that incorporates the system ventilation efficiency used in the simplified procedure. This results in a more accurate first-pass estimate of ventilation required at the outdoor air intake for many systems.	June 23, 2018 June 27, 2018 June 28, 2018
ad	6.5, 6.5.1	Table 6.5 (Minimum Exhaust Rates) lists minimum exhaust rates for certain spaces in which contaminants generation have been deemed high enough that the contaminant cannot be diluted and thus need to be exhausted. However, the standard does not require these spaces to be at any pressure. This addendum adds the requirement for these spaces to be at a negative pressure with respect to adjacent spaces in order to minimize contaminants leakage to adjacent spaces	July 22, 2019 August 1, 2019 August 26, 2019
ae	5.9	This addendum establishes a 60°F (15°C) indoor air dew-point limit that avoids the microbial growth problems frequently observed when humid outdoor air infiltrates into buildings that are mechanically cooled.	July 22, 2019 August 1, 2019 August 26, 2019
af	3; Table 6.2.2.1	The 2018 FGI (Facilities Guidelines Institute) guideline requires certain outpatient spaces to meet local ventilation codes and not ASHRAE/ASHRAE Standard 170. Neither one of the two mechanical model codes (IMC and UMC) has ventilation rates for these spaces. The IMC and UMC use ASHRAE Standard 62.1 as basis for their ventilation table. This addendum adds ventilation rates for those spaces in order to bridge the gap with ASHRAE/ASHRAE Standard 170. It was developed in consultation with FGI in order to understand the activity in each space.	July 22, 2019 August 1, 2019 August 26, 2019

\* These descriptions may not be complete and are provided for information only.



Table O-1 Addenda to ANSI/ASHRAE Standard 62.1-2016

Addendum	Section(s) Affected	Description of Changes*	Approval Dates:
ah	3; 6.2.2.2; Table 6.2.2.2; A3; (NEW) Normative Appendix X	Addendum ah clarifies and expands the values of zone air distribution effectiveness in Table 6.2.2.1 and adds Normative Appendix X, “Zone Air Distribution Effectiveness—Alternate Procedures,” to provide a procedure for calculating zone air distribution effectiveness. Notes on Table 6.2.2.1 have also been removed and replaced with definitions or specific requirements within the language of the standard.	June 22, 2019 June 26, 2019 June 27, 2019
ai	7.2.2	Addendum ai removes language published in Addendum q to Standard 62.1-2016. It reinstates the option of using indirect measurement techniques in testing and balancing (TAB) of the ventilation system in startup.	June 22, 2019 June 26, 2019 June 27, 2019
aj	(NEW) 5.7	<p>The current standard is silent on producing ozone within HVAC equipment. In some countries, ozone generators are accepted as air cleaners. In a recent poll of members of SSPC62.1, only 2% thought that having ozone producing components in a ventilation system is consistent with acceptable indoor air quality.</p> <p>Ozone is harmful for health, and exposure to ozone creates risk for a variety of symptoms and diseases associated with the respiratory tract. Many products of ozone homogeneous and heterogeneous reaction processes also create risks for health, including formaldehyde, unsaturated aldehydes (produced during the reaction of ozone with ketones and alcohols), and ultrafine particles (secondary organic aerosols).</p> <p>Ozone emission is thus undesirable. However, there is no consensus on the safe level of ozone. For example, ASHRAE’s Environmental Health Committee issued an emerging issue brief suggesting “safe ozone levels would be lower than 10 ppb” and that “the introduction of ozone to indoor spaces should be reduced to as low as reasonably achievable (ALARA) levels.” Still, even widely used guidelines are not entirely consistent with all available epidemiological literature on the effects of ozone, and there is relatively little known about the long-term effects of exposure to low concentrations of ozone.</p> <p>The current state of the science regarding the health effects of ozone strongly suggests that the use of air cleaners that emit ozone by design should not be permitted; the same information and advice is given by the USEPA, among others. There is more uncertainty about recommendations for air cleaners that do not use ozone by design for air cleaning but produce ozone unintentionally, as a by-product of their operation. There are devices that emit ozone but at the same time reduce concentrations of other harmful contaminants. The state of the science does not allow making highly certain trade-offs between increased exposure to ozone and the ozone reaction byproducts and reduced exposure to other contaminants.</p>	June 22, 2019 June 26, 2019 July 24, 2019
al	(NEW) 6.2.7.1.3; Table 8.2	The current standard has no requirements for accuracy of CO <sub>2</sub> sensors used for demand control ventilation. Various research projects show wide variation in accuracy and drift. This addendum adds language from the 2013 California Title 24 Section 120.1(c)(4)F.	July 22, 2019 August 1, 2019 August 26, 2019

\* These descriptions may not be complete and are provided for information only.



**Table O-1 Addenda to ANSI/ASHRAE Standard 62.1-2016**

<b>Addendum</b>	<b>Section(s) Affected</b>	<b>Description of Changes*</b>	<b>Approval Dates:</b>
am	(NEW) 6.5.1.1	When Addendum r to Standard 62.1-2016 was published, the footnote to old Table 5.16.1, "Airstreams or Sources," did not transfer to new the Table 6.5.2. This addendum reinstates the note into Section 6.	<ul style="list-style-type: none"> <li>• Standards Committee</li> <li>• ASHRAE BOD/ Tech Council</li> <li>• ANSI</li> </ul> June 22, 2019 June 26, 2019 June 27, 2019
an	3	This addendum clarifies that college classrooms may use Note H in Table 6.2.2.1 and have the ventilation shut off when they are unoccupied.	July 22, 2019 August 1, 2019 August 26, 2019
ap	9; Informative Appendix J	Addendum ap updates publication dates and URIs in Section 9, "References," and Informative Appendix J, "Informative References."	June 22, 2019 June 26, 2019 June 27, 2019
aq	Table 6.2.2.1	Many manufacturing occupancies do not use hazardous materials. This addendum changes the air class for those spaces to Air Class 2, which allows the air to be recirculated to other similar manufacturing areas. Manufacturing spaces using hazardous materials will remain Air Class 3.	June 22, 2019 June 26, 2019 July 24, 2019
ar	Informative Appendix E	Addendum ar modifies language in Informative Appendix E, "Acceptable Mass Balance Equations for Use with the IAQ Procedure," to be consistent with the current IAQP. It also clarifies that the equations do not include any potential compounds added by the HVAC system.	June 22, 2019 June 26, 2019 June 27, 2019
as	6.2.2; 9	This addendum adds a reference to ASHRAE/ASHE Standard 170 and an exception to direct users to use the ventilation rates in ASHRAE/ASHE Standard 170 for asepsis and odor control for healthcare spaces listed in ASHRAE/ASHE Standard 170.	July 22, 2019 August 1, 2019 August 26, 2019

\* These descriptions may not be complete and are provided for information only.

**NOTE**

**Approved addenda, errata, or interpretations for this standard can be downloaded free of charge from the ASHRAE website at [www.ashrae.org/technology](http://www.ashrae.org/technology).**



## **POLICY STATEMENT DEFINING ASHRAE'S CONCERN FOR THE ENVIRONMENTAL IMPACT OF ITS ACTIVITIES**

ASHRAE is concerned with the impact of its members' activities on both the indoor and outdoor environment. ASHRAE's members will strive to minimize any possible deleterious effect on the indoor and outdoor environment of the systems and components in their responsibility while maximizing the beneficial effects these systems provide, consistent with accepted Standards and the practical state of the art.

ASHRAE's short-range goal is to ensure that the systems and components within its scope do not impact the indoor and outdoor environment to a greater extent than specified by the Standards and Guidelines as established by itself and other responsible bodies.

As an ongoing goal, ASHRAE will, through its Standards Committee and extensive Technical Committee structure, continue to generate up-to-date Standards and Guidelines where appropriate and adopt, recommend, and promote those new and revised Standards developed by other responsible organizations.

Through its *Handbook*, appropriate chapters will contain up-to-date Standards and design considerations as the material is systematically revised.

ASHRAE will take the lead with respect to dissemination of environmental information of its primary interest and will seek out and disseminate information from other responsible organizations that is pertinent, as guides to updating Standards and Guidelines.

The effects of the design and selection of equipment and systems will be considered within the scope of the system's intended use and expected misuse. The disposal of hazardous materials, if any, will also be considered.

ASHRAE's primary concern for environmental impact will be at the site where equipment within ASHRAE's scope operates. However, energy source selection and the possible environmental impact due to the energy source and energy transportation will be considered where possible. Recommendations concerning energy source selection should be made by its members.

## About ASHRAE

Founded in 1894, ASHRAE is a global professional society committed to serve humanity by advancing the arts and sciences of heating, ventilation, air conditioning, refrigeration, and their allied fields.

As an industry leader in research, standards writing, publishing, certification, and continuing education, ASHRAE and its members are dedicated to promoting a healthy and sustainable built environment for all, through strategic partnerships with organizations in the HVAC&R community and across related industries.

To stay current with this and other ASHRAE Standards and Guidelines, visit [www.ashrae.org/standards](http://www.ashrae.org/standards), and connect on LinkedIn, Facebook, Twitter, and YouTube.

## Visit the ASHRAE Bookstore

ASHRAE offers its Standards and Guidelines in print, as immediately downloadable PDFs, and via ASHRAE Digital Collections, which provides online access with automatic updates as well as historical versions of publications. Selected Standards and Guidelines are also offered in redline versions that indicate the changes made between the active Standard or Guideline and its previous version. For more information, visit the Standards and Guidelines section of the ASHRAE Bookstore at [www.ashrae.org/bookstore](http://www.ashrae.org/bookstore).

### IMPORTANT NOTICES ABOUT THIS STANDARD

**To ensure that you have all of the approved addenda, errata, and interpretations for this Standard, visit [www.ashrae.org/standards](http://www.ashrae.org/standards) to download them free of charge.**

**Addenda, errata, and interpretations for ASHRAE Standards and Guidelines are no longer distributed with copies of the Standards and Guidelines. ASHRAE provides these addenda, errata, and interpretations only in electronic form to promote more sustainable use of resources.**

**TAB 2**



# Transmission of SARS-CoV-2: implications for infection prevention precautions

## Scientific Brief

9 July 2020

---

This document is an update to the scientific brief published on 29 March 2020 entitled “Modes of transmission of virus causing COVID-19: implications for infection prevention and control (IPC) precaution recommendations” and includes new scientific evidence available on transmission of SARS-CoV-2, the virus that causes COVID-19.

## Overview

This scientific brief provides an overview of the modes of transmission of SARS-CoV-2, what is known about when infected people transmit the virus, and the implications for infection prevention and control precautions within and outside health facilities. This scientific brief is not a systematic review. Rather, it reflects the consolidation of rapid reviews of publications in peer-reviewed journals and of non-peer-reviewed manuscripts on pre-print servers, undertaken by WHO and partners. Preprint findings should be interpreted with caution in the absence of peer review. This brief is also informed by several discussions via teleconferences with the WHO Health Emergencies Programme ad hoc Experts Advisory Panel for IPC Preparedness, Readiness and Response to COVID-19, the WHO ad hoc COVID-19 IPC Guidance Development Group (COVID-19 IPC GDG), and by review of external experts with relevant technical backgrounds.

The overarching aim of the global Strategic Preparedness and Response Plan for COVID-19<sup>(1)</sup> is to control COVID-19 by suppressing transmission of the virus and preventing associated illness and death. Current evidence suggests that SARS-CoV-2, the virus that causes COVID-19, is predominantly spread from person-to-person. Understanding how, when and in what types of settings SARS-CoV-2 spreads is critical to develop effective public health and infection prevention and control measures to break chains of transmission.

## Modes of transmission

This section briefly describes possible modes of transmission for SARS-CoV-2, including contact, droplet, airborne, fomite, fecal-oral, bloodborne, mother-to-child, and animal-to-human transmission. Infection with SARS-CoV-2 primarily causes respiratory illness ranging from mild disease to severe disease and death, and some people infected with the virus never develop symptoms.

### Contact and droplet transmission

Transmission of SARS-CoV-2 can occur through direct, indirect, or close contact with infected people through infected secretions such as saliva and respiratory secretions or their respiratory droplets, which are expelled when an infected person coughs, sneezes, talks or sings.<sup>(2-10)</sup> Respiratory droplets are  $>5-10\ \mu\text{m}$  in diameter whereas droplets  $\leq 5\ \mu\text{m}$  in diameter are referred to as droplet nuclei or aerosols.<sup>(11)</sup> Respiratory droplet transmission can occur when a person is in close contact (within 1 metre) with an infected person who has respiratory symptoms (e.g. coughing or sneezing) or who is talking or singing; in these circumstances, respiratory droplets that include virus can reach the mouth, nose or eyes of a susceptible person and can result in infection. Indirect contact transmission involving contact of a susceptible host with a contaminated object or surface (fomite transmission) may also be possible (see below).

### Airborne transmission

Airborne transmission is defined as the spread of an infectious agent caused by the dissemination of droplet nuclei (aerosols) that remain infectious when suspended in air over long distances and time.<sup>(11)</sup> Airborne transmission of SARS-CoV-2 can occur during medical procedures that generate aerosols (“aerosol generating procedures”).<sup>(12)</sup> WHO, together with the scientific community, has been actively discussing and evaluating whether SARS-CoV-2 may also spread through aerosols in the absence of aerosol generating procedures, particularly in indoor settings with poor ventilation.

The physics of exhaled air and flow physics have generated hypotheses about possible mechanisms of SARS-CoV-2 transmission through aerosols.(13-16) These theories suggest that 1) a number of respiratory droplets generate microscopic aerosols (<5 µm) by evaporating, and 2) normal breathing and talking results in exhaled aerosols. Thus, a susceptible person could inhale aerosols, and could become infected if the aerosols contain the virus in sufficient quantity to cause infection within the recipient. However, the proportion of exhaled droplet nuclei or of respiratory droplets that evaporate to generate aerosols, and the infectious dose of viable SARS-CoV-2 required to cause infection in another person are not known, but it has been studied for other respiratory viruses.(17)

One experimental study quantified the amount of droplets of various sizes that remain airborne during normal speech. However, the authors acknowledge that this relies on the independent action hypothesis, which has not been validated for humans and SARS-CoV-2.(18) Another recent experimental model found that healthy individuals can produce aerosols through coughing and talking (19), and another model suggested high variability between individuals in terms of particle emission rates during speech, with increased rates correlated with increased amplitude of vocalization.(20) To date, transmission of SARS-CoV-2 by this type of aerosol route has not been demonstrated; much more research is needed given the possible implications of such route of transmission.

Experimental studies have generated aerosols of infectious samples using high-powered jet nebulizers under controlled laboratory conditions. These studies found SARS-CoV-2 virus RNA in air samples within aerosols for up to 3 hours in one study (21) and 16 hours in another, which also found viable replication-competent virus.(22) These findings were from experimentally induced aerosols that do not reflect normal human cough conditions.

Some studies conducted in health care settings where symptomatic COVID-19 patients were cared for, but where aerosol generating procedures were not performed, reported the presence of SARS-CoV-2 RNA in air samples (23-28), while other similar investigations in both health care and non-health care settings found no presence of SARS-CoV-2 RNA; no studies have found viable virus in air samples.(29-36) Within samples where SARS-CoV-2 RNA was found, the quantity of RNA detected was in extremely low numbers in large volumes of air and one study that found SARS-CoV-2 RNA in air samples reported inability to identify viable virus. (25) The detection of RNA using reverse transcription polymerase chain reaction (RT-PCR)-based assays is not necessarily indicative of replication- and infection-competent (viable) virus that could be transmissible and capable of causing infection.(37)



Recent clinical reports of health workers exposed to COVID-19 index cases, not in the presence of aerosol-generating procedures, found no nosocomial transmission when contact and droplet precautions were appropriately used, including the wearing of medical masks as a component of the personal protective equipment (PPE). (38, 39) These observations suggest that aerosol transmission did not occur in this context. Further studies are needed to determine whether it is possible to detect viable SARS-CoV-2 in air samples from settings where no procedures that generate aerosols are performed and what role aerosols might play in transmission.

Outside of medical facilities, some outbreak reports related to indoor crowded spaces (40) have suggested the possibility of aerosol transmission, combined with droplet transmission, for example, during choir practice (7), in restaurants (41) or in fitness classes. (42) In these events, short-range aerosol transmission, particularly in specific indoor locations, such as crowded and inadequately ventilated spaces over a prolonged period of time with infected persons cannot be ruled out. However, the detailed investigations of these clusters suggest that droplet and fomite transmission could also explain human-to-human transmission within these clusters. Further, the close contact environments of these clusters may have facilitated transmission from a small number of cases to many other people (e.g., superspreading event), especially if hand hygiene was not performed and masks were not used when physical distancing was not maintained. (43)

## Fomite transmission

Respiratory secretions or droplets expelled by infected individuals can contaminate surfaces and objects, creating fomites (contaminated surfaces). Viable SARS-CoV-2 virus and/or RNA detected by RT-PCR can be found on those surfaces for periods ranging from hours to days, depending on the ambient environment (including temperature and humidity) and the type of surface, in particular at high concentration in health care facilities where COVID-19 patients were being treated. (21, 23, 24, 26, 28, 31-33, 36, 44, 45) Therefore, transmission may also occur indirectly through touching surfaces in the immediate environment or objects contaminated with virus from an infected person (e.g. stethoscope or thermometer), followed by touching the mouth, nose, or eyes.

Despite consistent evidence as to SARS-CoV-2 contamination of surfaces and the survival of the virus on certain surfaces, there are no specific reports which have directly demonstrated fomite transmission. People who come into contact with potentially infectious surfaces often also have close contact with the infectious person, making the distinction between respiratory droplet and fomite transmission difficult to discern. However, fomite transmission is considered a likely mode of

transmission for SARS-CoV-2, given consistent findings about environmental contamination in the vicinity of infected cases and the fact that other coronaviruses and respiratory viruses can transmit this way.

## Other modes of transmission

SARS-CoV-2 RNA has also been detected in other biological samples, including the urine and feces of some patients.<sup>(46-50)</sup> One study found viable SARS-CoV-2 in the urine of one patient.<sup>(51)</sup> Three studies have cultured SARS-CoV-2 from stool specimens. <sup>(48, 52, 53)</sup> To date, however, there have been no published reports of transmission of SARS-CoV-2 through feces or urine.

Some studies have reported detection of SARS-CoV-2 RNA, in either plasma or serum, and the virus can replicate in blood cells. However, the role of bloodborne transmission remains uncertain; and low viral titers in plasma and serum suggest that the risk of transmission through this route may be low.<sup>(48, 54)</sup> Currently, there is no evidence for intrauterine transmission of SARS-CoV-2 from infected pregnant women to their fetuses, although data remain limited. WHO has recently published a scientific brief on breastfeeding and COVID-19.<sup>(55)</sup> This brief explains that viral RNA fragments have been found by RT-PCR testing in a few breast milk samples of mothers infected with SARS-CoV-2, but studies investigating whether the virus could be isolated, have found no viable virus. Transmission of SARS-CoV-2 from mother to child would necessitate replicative and infectious virus in breast milk being able to reach target sites in the infant and also to overcome infant defense systems. WHO recommends that mothers with suspected or confirmed COVID-19 should be encouraged to initiate or continue to breastfeed.<sup>(55)</sup>

Evidence to date shows that SARS-CoV-2 is most closely related to known betacoronaviruses in bats; the role of an intermediate host in facilitating transmission in the earliest known human cases remains unclear.<sup>(56, 57)</sup> In addition to investigations on the possible intermediate host(s) of SARS-CoV-2, there are also a number of studies underway to better understand susceptibility of SARS-CoV-2 in different animal species. Current evidence suggests that humans infected with SARS-CoV-2 can infect other mammals, including dogs<sup>(58)</sup>, cats<sup>(59)</sup>, and farmed mink.<sup>(60)</sup> However, it remains unclear if these infected mammals pose a significant risk for transmission to humans.

## When do people infected with SARS-CoV-2 infect others?

Knowing when an infected person can spread SARS-CoV-2 is just as important as how the virus spreads (described above). WHO has recently published a scientific brief outlining what is known about when a person may be able to spread, based on the severity of their illness.(61)

In brief, evidence suggests that SARS-CoV-2 RNA can be detected in people 1-3 days before their symptom onset, with the highest viral loads, as measured by RT-PCR, observed around the day of symptom onset, followed by a gradual decline over time.(47, 62-65) The duration of RT-PCR positivity generally appears to be 1-2 weeks for asymptomatic persons, and up to 3 weeks or more for patients with mild to moderate disease.(62, 65-68) In patients with severe COVID-19 disease, it can be much longer.(47)

Detection of viral RNA does not necessarily mean that a person is infectious and able to transmit the virus to another person. Studies using viral culture of patient samples to assess the presence of infectious SARS-CoV-2 are currently limited. (61) Briefly, viable virus has been isolated from an asymptomatic case,(69) from patients with mild to moderate disease up to 8-9 days after symptom onset, and for longer from severely ill patients.(61) Full details about the duration of viral shedding can be found in the WHO guidance document on “Criteria for releasing COVID-19 patients from isolation”. (61) Additional studies are needed to determine the duration of viable virus shedding among infected patients.

## **SARS-CoV-2 infected persons who have symptoms can infect others primarily through droplets and close contact**

SARS-CoV-2 transmission appears to mainly be spread via droplets and close contact with infected symptomatic cases. In an analysis of 75,465 COVID-19 cases in China, 78-85% of clusters occurred within household settings, suggesting that transmission occurs during close and prolonged contact.(6) A study of the first patients in the Republic of Korea showed that 9 of 13 secondary cases occurred among household contacts.(70) Outside of the household setting, those who had close physical contact, shared meals, or were in enclosed spaces for approximately one hour or more with symptomatic cases, such as in places of worship, gyms, or the workplace, were also at increased risk of infection.(7, 42, 71, 72) Other reports have supported this with similar findings of secondary transmission within families in other countries.(73, 74)

## **SARS-CoV-2 infected persons without symptoms can also infect others**

Early data from China suggested that people without symptoms could infect others.<sup>(6)</sup> To better understand the role of transmission from infected people without symptoms, it is important to distinguish between transmission from people who are infected who never develop symptoms<sup>(75)</sup> (asymptomatic transmission) and transmission from people who are infected but have not developed symptoms yet (pre-symptomatic transmission). This distinction is important when developing public health strategies to control transmission.

The extent of truly asymptomatic infection in the community remains unknown. The proportion of people whose infection is asymptomatic likely varies with age due to the increasing prevalence of underlying conditions in older age groups (and thus increasing risk of developing severe disease with increasing age), and studies that show that children are less likely to show clinical symptoms compared to adults.<sup>(76)</sup> Early studies from the United States<sup>(77)</sup> and China<sup>(78)</sup> reported that many cases were asymptomatic, based on the lack of symptoms at the time of testing; however, 75-100% of these people later developed symptoms. A recent systematic review estimated that the proportion of truly asymptomatic cases ranges from 6% to 41%, with a pooled estimate of 16% (12%–20%).<sup>(79)</sup> However, all studies included in this systematic review have important limitations.<sup>(79)</sup> For example, some studies did not clearly describe how they followed up with persons who were asymptomatic at the time of testing to ascertain if they ever developed symptoms, and others defined “asymptomatic” very narrowly as persons who never developed fever or respiratory symptoms, rather than as those who did not develop any symptoms at all.<sup>(76, 80)</sup> A recent study from China that clearly and appropriately defined asymptomatic infections suggests that the proportion of infected people who never developed symptoms was 23%.<sup>(81)</sup>

Multiple studies have shown that people infect others before they themselves became ill, <sup>(10, 42, 69, 82, 83)</sup> which is supported by available viral shedding data (see above). One study of transmission in Singapore reported that 6.4% of secondary cases resulted from pre-symptomatic transmission.<sup>(73)</sup> One modelling study, that inferred the date of transmission based on the estimated serial interval and incubation period, estimated that up to 44% (25-69%) of transmission may have occurred just before symptoms appeared.<sup>(62)</sup> It remains unclear why the magnitude of estimates from modelling studies differs from available empirical data.

Transmission from infected people without symptoms is difficult to study. However, information can be gathered from detailed contact tracing efforts, as well as epidemiologic investigations among cases and contacts. Information from contact tracing efforts reported to WHO by Member States, available transmission studies and a recent pre-print systematic reviews suggests that individuals without symptoms are less likely to transmit the virus than those who develop symptoms.<sup>(10, 81, 84,</sup>

85) Four individual studies from Brunei, Guangzhou China, Taiwan China and the Republic of Korea found that between 0% and 2.2% of people with asymptomatic infection infected anyone else, compared to 0.8%-15.4% of people with symptoms. (10, 72, 86, 87)

## Remaining questions related to transmission

Many unanswered questions about transmission of SARS-CoV-2 remain, and research seeking to answer those questions is ongoing and is encouraged. Current evidence suggests that SARS-CoV-2 is primarily transmitted between people via respiratory droplets and contact routes – although aerosolization in medical settings where aerosol generating procedures are used is also another possible mode of transmission - and that transmission of COVID-19 is occurring from people who are pre-symptomatic or symptomatic to others in close contact (direct physical or face-to-face contact with a probable or confirmed case within one meter and for prolonged periods of time), when not wearing appropriate PPE. Transmission can also occur from people who are infected and remain asymptomatic, but the extent to which this occurs is not fully understood and requires further research as an urgent priority. The role and extent of airborne transmission outside of health care facilities, and in particular in close settings with poor ventilation, also requires further study.

As research continues, we expect to gain a better understanding about the relative importance of different transmission routes, including through droplets, physical contact and fomites; the role of airborne transmission in the absence of aerosol generating procedures; the dose of virus required for transmission to occur, the characteristics of people and situations that facilitate superspreading events such as those observed in various closed settings, the proportion of infected people who remain asymptomatic throughout the course of their infection; the proportion of truly asymptomatic persons who transmit the virus to others; the specific factors that drive asymptomatic and pre-symptomatic transmission; and the proportion of all infections that are transmitted from asymptomatic and pre-symptomatic individuals.

## Implications for preventing transmission

Understanding how, when and in which settings infected people transmit the virus is important for developing and implementing control measures to break chains of transmission. While there is a great deal of scientific studies becoming available, all studies that investigate transmission should be interpreted bearing in mind the context and settings in which they took place, including the infection prevention interventions in place, the rigor of the methods used in the investigation and the limitations and biases of the study designs.

It is clear from available evidence and experience, that limiting close contact between infected people and others is central to breaking chains of transmission of the virus causing COVID-19. The prevention of transmission is best achieved by identifying suspect cases as quickly as possible, testing, and isolating infectious cases. (88, 89) In addition, it is critical to identify all close contacts of infected people (88) so that they can be quarantined (90) to limit onward spread and break chains of transmission. By quarantining close contacts, potential secondary cases will already be separated from others before they develop symptoms or they start shedding virus if they are infected, thus preventing the opportunity for further onward spread. The incubation period of COVID-19, which is the time between exposure to the virus and symptom onset, is on average 5-6 days, but can be as long as 14 days. (82, 91) Thus, quarantine should be in place for 14 days from the last exposure to a confirmed case. If it is not possible for a contact to quarantine in a separate living space, self-quarantine for 14 days at home is required; those in self-quarantine may require support during the use of physical distancing measures to prevent the spread of the virus.

Given that infected people without symptoms can transmit the virus, it is also prudent to encourage the use of fabric face masks in public places where there is community transmission[1] and where other prevention measures, such as physical distancing, are not possible.(12) Fabric masks, if made and worn properly, can serve as a barrier to droplets expelled from the wearer into the air and environment.(12) However, masks must be used as part of a comprehensive package of preventive measures, which includes frequent hand hygiene, physical distancing when possible, respiratory etiquette, environmental cleaning and disinfection. Recommended precautions also include avoiding indoor crowded gatherings as much as possible, in particular when physical distancing is not feasible, and ensuring good environmental ventilation in any closed setting. (92, 93)

Within health care facilities, including long term care facilities, based on the evidence and the advice by the COVID-19 IPC GDG, WHO continues to recommend droplet and contact precautions when caring for COVID-19 patients and airborne precautions when and where aerosol generating procedures are performed. WHO also recommends standard or transmission-based precautions for other patients using an approach guided by risk assessment.(94) These recommendations are consistent with other national and international guidelines, including those developed by the European Society of Intensive Care Medicine and Society of Critical Care Medicine (95) and by the Infectious Diseases Society of America. (96)

Furthermore, in areas with COVID-19 community transmission, WHO advises that health workers and caregivers working in clinical areas should continuously wear a medical mask during all routine activities throughout the entire shift.(12) In settings where aerosol-generating procedures are performed, they should wear an N95, FFP2 or FFP3 respirator. Other countries and organizations, including the United States Centers for Diseases Control and Prevention (97) and the European



Centre for Disease Prevention and Control (98) recommend airborne precautions for any situation involving the care of COVID-19 patients. However, they also consider the use of medical masks as an acceptable option in case of shortages of respirators.

WHO guidance also emphasizes the importance of administrative and engineering controls in health care settings, as well as rational and appropriate use of all PPE (99) and training for staff on these recommendations (IPC for Novel Coronavirus [COVID-19] Course. Geneva; World Health Organization 2020, available at (<https://openwho.org/courses/COVID-19-IPC-EN>). WHO has also provided guidance on safe workplaces. (92)

## Key points of the brief

### Main findings

- Understanding how, when and in what types of settings SARS-CoV-2 spreads between people is critical to develop effective public health and infection prevention measures to break chains of transmission.
- Current evidence suggests that transmission of SARS-CoV-2 occurs primarily between people through direct, indirect, or close contact with infected people through infected secretions such as saliva and respiratory secretions, or through their respiratory droplets, which are expelled when an infected person coughs, sneezes, talks or sings.
- Airborne transmission of the virus can occur in health care settings where specific medical procedures, called aerosol generating procedures, generate very small droplets called aerosols. Some outbreak reports related to indoor crowded spaces have suggested the possibility of aerosol transmission, combined with droplet transmission, for example, during choir practice, in restaurants or in fitness classes.
- Respiratory droplets from infected individuals can also land on objects, creating fomites (contaminated surfaces). As environmental contamination has been documented by many reports, it is likely that people can also be infected by touching these surfaces and touching their eyes, nose or mouth before cleaning their hands.
- Based on what we currently know, transmission of COVID-19 is primarily occurring from people when they have symptoms, and can also occur just before they develop symptoms, when they are in close proximity to others for prolonged periods of time. While someone who never develops symptoms can also pass the virus to others, it is still not clear to what extent this occurs and more research is needed in this area.
- Urgent high-quality research is needed to elucidate the relative importance of different transmission routes; the role of airborne transmission in the absence of aerosol generating procedures; the dose of virus required for transmission to occur; the settings and risk factors for superspreading events; and the extent of asymptomatic and pre-symptomatic transmission.

# How to prevent transmission

The overarching aim of the Strategic Preparedness and Response Plan for COVID-19<sup>[1]</sup> is to control COVID-19 by suppressing transmission of the virus and preventing associated illness and death. To the best of our understanding, the virus is primarily spread through contact and respiratory droplets. Under some circumstances airborne transmission may occur (such as when aerosol generating procedures are conducted in health care settings or potentially, in indoor crowded poorly ventilated settings elsewhere). More studies are urgently needed to investigate such instances and assess their actual significance for transmission of COVID-19.

To prevent transmission, WHO recommends a comprehensive set of measures including:

- Identify suspect cases as quickly as possible, test, and isolate all cases (infected people) in appropriate facilities;
- Identify and quarantine all close contacts of infected people and test those who develop symptoms so that they can be isolated if they are infected and require care;
- Use fabric masks in specific situations, for example, in public places where there is community transmission and where other prevention measures, such as physical distancing, are not possible;
- Use of contact and droplet precautions by health workers caring for suspected and confirmed COVID-19 patients, and use of airborne precautions when aerosol generating procedures are performed;
- Continuous use of a medical mask by health workers and caregivers working in all clinical areas, during all routine activities throughout the entire shift;
- At all times, practice frequent hand hygiene, physical distancing from others when possible, and respiratory etiquette; avoid crowded places, close-contact settings and confined and enclosed spaces with poor ventilation; wear fabric masks when in closed, overcrowded spaces to protect others; and ensure good environmental ventilation in all closed settings and appropriate environmental cleaning and disinfection.

WHO carefully monitors the emerging evidence about this critical topic and will update this scientific brief as more information becomes available.

[1] Defined by WHO as “experiencing larger outbreaks of local transmission defined through an assessment of factors including, but not limited to: large numbers of cases not linkable to transmission chains; large numbers of cases from sentinel surveillance; and/or multiple unrelated clusters in several areas of the country/territory/area” (<https://www.who.int/publications-detail/global-surveillance-for-covid-19-caused-by-human-infection-with-covid-19-virus-interim-guidance>)

## References



1. Operational planning guidance to support country preparedness and response. Geneva: World Health Organization; 2020 (available at <https://www.who.int/publications/i/item/draft-operational-planning-guidance-for-un-country-teams>).
2. Liu J, Liao X, Qian S, Yuan J, Wang F, Liu Y, et al. Community Transmission of Severe Acute Respiratory Syndrome Coronavirus 2, Shenzhen, China, 2020. *Emerg Infect Dis.* 2020;26:1320-3.
3. Chan JF-W, Yuan S, Kok K-H, To KK-W, Chu H, Yang J, et al. A familial cluster of pneumonia associated with the 2019 novel coronavirus indicating person-to-person transmission: a study of a family cluster. *Lancet.* 2020;395:14-23.
4. Huang C, Wang Y, Li X, Ren L, Zhao J, Hu Y, et al. Clinical features of patients infected with 2019 novel coronavirus in Wuhan, China. *Lancet.* 2020;395:497-506.
5. Burke RM, Midgley CM, Dratch A, Fenstersheib M, Haupt T, Holshue M, et al. Active Monitoring of Persons Exposed to Patients with Confirmed COVID-19 — United States, January–February 2020. *MMWR Morb Mortal Wkly Rep.* 2020;69(24):245-6.
6. Report of the WHO-China Joint Mission on Coronavirus Disease 2019 (COVID-19) 16-24 February 2020. Geneva: World Health Organization; 2020 (available at <https://www.who.int/docs/default-source/coronaviruse/who-china-joint-mission-on-covid-19-final-report.pdf>).
7. Hamner L, Dubbel P, Capron I, Ross A, Jordan A, Lee J, et al. High SARS-CoV-2 Attack Rate Following Exposure at a Choir Practice — Skagit County, Washington, March 2020. *MMWR Morb Mortal Wkly Rep.* 2020;69(10):606-10.
8. Ghinai I, McPherson TD, Hunter JC, Kirking HL, Christiansen D, Joshi K, et al. First known person-to-person transmission of severe acute respiratory syndrome coronavirus 2 (SARS-CoV-2) in the USA. *Lancet.* 2020;395:1137-44.
9. Pung R, Chiew CJ, Young BE, Chin S, Chen MIC, Clapham HE, et al. Investigation of three clusters of COVID-19 in Singapore: implications for surveillance and response measures. *Lancet.* 2020;395:1039-46.
10. Luo L, Liu D, Liao X, Wu X, Jing Q, Zheng J, et al. Modes of contact and risk of transmission in COVID-19 among close contacts (pre-print). *MedRxiv.* 2020 doi:10.1101/2020.03.24.20042606.
11. Infection Prevention and Control of Epidemic-and Pandemic-prone Acute Respiratory Infections in Health Care. Geneva: World Health Organization; 2014 (available at [https://apps.who.int/iris/bitstream/handle/10665/112656/9789241507134\\_eng.pdf;jsessionid=41AA684f](https://apps.who.int/iris/bitstream/handle/10665/112656/9789241507134_eng.pdf;jsessionid=41AA684f)

sequence=1).

12. Advice on the use of masks in the context of COVID-19. Interim guidance. Geneva: World Health Organization; 2020 (available at [https://www.who.int/publications/i/item/advice-on-the-use-of-masks-in-the-community-during-home-care-and-in-healthcare-settings-in-the-context-of-the-novel-coronavirus-\(2019-ncov\)-outbreak](https://www.who.int/publications/i/item/advice-on-the-use-of-masks-in-the-community-during-home-care-and-in-healthcare-settings-in-the-context-of-the-novel-coronavirus-(2019-ncov)-outbreak)).

13. Mittal R, Ni R, Seo J-H. The flow physics of COVID-19. *J Fluid Mech.* 2020;894.

14. Bourouiba L. Turbulent Gas Clouds and Respiratory Pathogen Emissions: Potential Implications for Reducing Transmission of COVID-19. *JAMA.* 2020;323(18):1837-1838..

15. Asadi S, Bouvier N, Wexler AS, Ristenpart WD. The coronavirus pandemic and aerosols: Does COVID-19 transmit via expiratory particles? *Aerosol Sci Technol.* 2020;54:635-8.

16. Morawska L, Cao J. Airborne transmission of SARS-CoV-2: The world should face the reality. *Environ Int.* 2020;139:105730.

17. Gralton J Tovey TR, McLaws M-L, Rawlinson WD. Respiratory Virus RNA is detectable in airborne and droplet particles. *J Med Virol.* 2013;85:2151-9.

18. Stadnytskyi V, Bax CE, Bax A, Anfinrud P. The airborne lifetime of small speech droplets and their potential importance in SARS-CoV-2 transmission. *Proc Ntl Acad Sci.* 2020;117:11875-7.

19. Somsen GA, van Rijn C, Kooij S, Bem RA, Bonn D. Small droplet aerosols in poorly ventilated spaces and SARS-CoV-2 transmission. *Lancet Respir Med.* 2020:S2213260020302459.

20. Asadi S, Wexler AS, Cappa CD, Barreda S, Bouvier NM, Ristenpart WD. Aerosol emission and superemission during human speech increase with voice loudness. *Sci Rep.* 2019;9:2348.

21. Van Doremalen N, Bushmaker T, Morris DH, Holbrook MG, Gamble A, Williamson BN, et al. Aerosol and surface stability of SARS-CoV-2 as compared with SARS-CoV-1. *N Engl J Med.* 2020;382:1564-7.

22. Fears AC, Klimstra WB, Duprex P, Weaver SC, Plante JA, Aguilar PV, et al. Persistence of Severe Acute Respiratory Syndrome Coronavirus 2 in Aerosol Suspensions. *Emerg Infect Dis* 2020;26(9).

23. Chia PY, for the Singapore Novel Coronavirus Outbreak Research T, Coleman KK, Tan YK, Ong SWX, Gum M, et al. Detection of air and surface contamination by SARS-CoV-2 in hospital rooms of infected patients. *Nat Comm.* 2020;11(1).

24. Guo Z-D, Wang Z-Y, Zhang S-F, Li X, Li L, Li C, et al. Aerosol and Surface Distribution of Severe Acute Respiratory Syndrome Coronavirus 2 in Hospital Wards, Wuhan, China, 2020. *Emerg Infect Dis.* 2020;26(7).
25. Santarpia JL, Rivera DN, Herrera V, Morwitzer MJ, Creager H, Santarpia GW, et al. Transmission potential of SARS-CoV-2 in viral shedding observed at the University of Nebraska Medical Center (pre-print). *MedRxiv.* 2020 doi: 10.1101/2020.03.23.20039446.
26. Zhou J, Otter J, Price JR, Cimpeanu C, Garcia DM, Kinross J, et al. Investigating SARS-CoV-2 surface and air contamination in an acute healthcare setting during the peak of the COVID-19 pandemic in London (pre-print). *MedRxiv.* 2020 doi: 10.1101/2020.05.24.20110346.
27. Liu Y, Ning Z, Chen Y, Guo M, Liu Y, Gali NK, et al. Aerodynamic analysis of SARS-CoV-2 in two Wuhan hospitals. *Nature.* 2020;582:557-60.
28. Ma J, Qi X, Chen H, Li X, Zhan Z, Wang H, et al. Exhaled breath is a significant source of SARS-CoV-2 emission (pre-print). *MedRxiv.* 2020 doi: 10.1101/2020.05.31.20115154.
29. Faridi S, Niazi S, Sadeghi K, Naddafi K, Yavarian J, Shamsipour M, et al. A field indoor air measurement of SARS-CoV-2 in the patient rooms of the largest hospital in Iran. *Sci Total Environ.* 2020;725:138401.
30. Cheng VC-C, Wong S-C, Chan VW-M, So SY-C, Chen JH-K, Yip CC-Y, et al. Air and environmental sampling for SARS-CoV-2 around hospitalized patients with coronavirus disease 2019 (COVID-19). *Infect Control Hosp Epidemiol.* 2020:1-32.
31. Ong SWX, Tan YK, Chia PY, Lee TH, Ng OT, Wong MSY, et al. Air, Surface Environmental, and Personal Protective Equipment Contamination by Severe Acute Respiratory Syndrome Coronavirus 2 (SARS-CoV-2) From a Symptomatic Patient. *JAMA.* 2020 323(16):1610-1612.
32. Taskforce for the COVID-19 Cruise Ship Outbreak, Yamagishi T. Environmental sampling for severe acute respiratory syndrome coronavirus 2 (SARS-CoV-2) during a coronavirus disease (COVID-19) outbreak aboard a commercial cruise ship (pre-print). *MedRxiv.* 2020.
33. Döhla M, Wilbring G, Schulte B, Kümmerer BM, Diegmann C, Sib E, et al. SARS-CoV-2 in environmental samples of quarantined households (pre-print). *MedRxiv.* 2020 doi: 10.1101/2020.05.02.20088567.
34. Wu S, Wang Y, Jin X, Tian J, Liu J, Mao Y. Environmental contamination by SARS-CoV-2 in a designated hospital for coronavirus disease 2019. *Am J Infect Control.* 2020;S0196-6553(20)30275-3.

35. Ding Z, Qian H, Xu B, Huang Y, Miao T, Yen H-L, et al. Toilets dominate environmental detection of SARS-CoV-2 virus in a hospital (pre-print). *MedRxiv*. 2020 doi: 10.1101/2020.04.03.20052175.
36. Cheng VCC, Wong SC, Chen JHK, Yip CCY, Chuang VWM, Tsang OTY, et al. Escalating infection control response to the rapidly evolving epidemiology of the coronavirus disease 2019 (COVID-19) due to SARS-CoV-2 in Hong Kong. *Infect Control Hosp Epidemiol*. 2020;41:493-8.
37. Bullard J, Dust K, Funk D, Strong JE, Alexander D, Garnett L, et al. Predicting infectious SARS-CoV-2 from diagnostic samples. *Clin Infect Dis*. 2020:ciaa638.
38. Durante-Mangoni E, Andini R, Bertolino L, Mele F, Bernardo M, Grimaldi M, et al. Low rate of severe acute respiratory syndrome coronavirus 2 spread among health-care personnel using ordinary personal protection equipment in a medium-incidence setting. *Clin Microbiol Infect*. 2020:S1198743X20302706.
39. Wong SCY, Kwong RTS, Wu TC, Chan JWM, Chu MY, Lee SY, et al. Risk of nosocomial transmission of coronavirus disease 2019: an experience in a general ward setting in Hong Kong. *J Hosp Infect*. 2020;105(2):119-27.
40. Leclerc QJ, Fuller NM, Knight LE, Funk S, Knight GM, Group CC-W. What settings have been linked to SARS-CoV-2 transmission clusters? *Wellcome Open Res*. 2020;5(83):83.
41. Lu J, Gu J, Li K, Xu C, Su W, Lai Z, et al. Early Release-COVID-19 Outbreak Associated with Air Conditioning in Restaurant, Guangzhou, China, 2020. *Emerg Infect Dis*. 2020;26(7):1628-1631.
42. Jang S, Han SH, Rhee J-Y. Cluster of Coronavirus Disease Associated with Fitness Dance Classes, South Korea. *Emerg Infect Dis*. 2020;26(8).
43. Adam D, Wu P, Wong J, Lau E, Tsang T, Cauchemez S, et al. Clustering and superspreading potential of severe acute respiratory syndrome coronavirus 2 (SARS-CoV-2) infections in Hong Kong (pre-print). *Research Square*. 2020. doi: 10.21203/rs.3.rs-29548/v1
44. Matson MJ, Yinda CK, Seifert SN, Bushmaker T, Fischer RJ, van Doremalen N, et al. Effect of Environmental Conditions on SARS-CoV-2 Stability in Human Nasal Mucus and Sputum. *Emerg Infect Dis*. 2020;26(9).
45. Pastorino B, Touret F, Gilles M, de Lamballerie X, Charrel RN. Prolonged Infectivity of SARS-CoV-2 in Fomites. *Emerg Infect Dis*. 2020;26(9).
46. Guan WJ, Ni ZY, Hu Y, Liang WH, Ou CQ, He JX, et al. Clinical Characteristics of Coronavirus Disease 2019 in China. *New Engl J Med*. 2020;382:1708-1720.

47. Pan Y, Zhang D, Yang P, Poon LLM, Wang Q. Viral load of SARS-CoV-2 in clinical samples. *Lancet Infect Dis.* 2020;20(4):411-2.
48. Wang W, Xu Y, Gao R, Lu R, Han K, Wu G, et al. Detection of SARS-CoV-2 in Different Types of Clinical Specimens. *JAMA.* 2020;323(18):1843-1844.
49. Wu Y, Guo C, Tang L, Hong Z, Zhou J, Dong X, et al. Prolonged presence of SARS-CoV-2 viral RNA in faecal samples. *Lancet Gastroenterol Hepatol.* 2020;5(5):434-5.
50. Zheng S, Fan J, Yu F, Feng B, Lou B, Zou Q, et al. Viral load dynamics and disease severity in patients infected with SARS-CoV-2 in Zhejiang province, China, January-March 2020: retrospective cohort study. *BMJ.* 2020:m1443.
51. Sun J, Zhu A, Li H, Zheng K, Zhuang Z, Chen Z, et al. Isolation of infectious SARS-CoV-2 from urine of a COVID-19 patient. *Emerg Microbes Infect.* 2020;9:991-3.
52. Xiao F, Sun J, Xu Y, Li F, Huang X, Li H, et al. Infectious SARS-CoV-2 in Feces of Patient with Severe COVID-19. *Emerg Infect Dis.* 2020;26(8).
53. Zhang Y, Chen C, Zhu S, Shu C, Wang D, Song J, et al. Isolation of 2019-nCoV from a stool specimen of a laboratory-confirmed case of the coronavirus disease 2019 (COVID-19). *China CDC Weekly.* 2020;2:123-4.
54. Chang L, Zhao L, Gong H, Wang L, Wang L. Severe Acute Respiratory Syndrome Coronavirus 2 RNA Detected in Blood Donations. *Emerg Infect Dis.* 2020;26:1631-3.
55. Breastfeeding and COVID-19. Geneva: World Health Organization; 2020 (available at <https://www.who.int/news-room/commentaries/detail/breastfeeding-and-covid-19>).
56. Andersen KG, Rambaut A, Lipkin WI, Holmes EC, Garry RF. The proximal origin of SARS-CoV-2. *Nat Med.* 2020;26(4):450-2.
57. Zhou P, Yang X-L, Wang X-G, Hu B, Zhang L, Zhang W, et al. A pneumonia outbreak associated with a new coronavirus of probable bat origin. *Nature.* 2020;579(7798):270-3.
58. Sit TH, Brackman CJ, Ip SM, Tam KW, Law PY, To EM, et al. Infection of dogs with SARS-CoV-2. *Nature.* 2020:1-6.
59. Newman A. First Reported Cases of SARS-CoV-2 Infection in Companion Animals—New York, March–April 2020. *MMWR Morbid Mortal Wkly Rep.* 2020; 69(23):710–713.

60. Oreshkova N, Molenaar R-J, Vreman S, Harders F, Munnink BBO, Honing RWH-v, et al. SARS-CoV2 infection in farmed mink, Netherlands, April 2020 (pre-print). *BioRxiv*. 2020 doi: 10.1101/2020.05.18.101493.
61. Criteria for releasing COVID-19 patients from isolation Geneva: World Health Organization; 2020 (available at <https://www.who.int/news-room/commentaries/detail/criteria-for-releasing-covid-19-patients-from-isolation> )
62. He X, Lau EH, Wu P, Deng X, Wang J, Hao X, et al. Temporal dynamics in viral shedding and transmissibility of COVID-19. *Nat Med*. 2020;26(5):672-5.
63. Zou L, Ruan F, Huang M, Liang L, Huang H, Hong Z, et al. SARS-CoV-2 viral load in upper respiratory specimens of infected patients. *New Engl J Med*. 2020;382(12):1177-9.
64. To KK-W, Tsang OT-Y, Leung W-S, Tam AR, Wu T-C, Lung DC, et al. Temporal profiles of viral load in posterior oropharyngeal saliva samples and serum antibody responses during infection by SARS-CoV-2: an observational cohort study. *Lancet Infect Dis*. 2020;20(5):P565-74.
65. Wölfel R, Corman VM, Guggemos W, Seilmaier M, Zange S, Müller MA, et al. Virological assessment of hospitalized patients with COVID-2019. *Nature*. 2020;581(7809):465-9.
66. Zhou R, Li F, Chen F, Liu H, Zheng J, Lei C, et al. Viral dynamics in asymptomatic patients with COVID-19. *Int J Infect Dis*. 2020;96:288-90.
67. Xu K, Chen Y, Yuan J, Yi P, Ding C, Wu W, et al. Factors associated with prolonged viral RNA shedding in patients with COVID-19. *Clin Infect Dis*. 2020;ciaa351.
68. Qi L, Yang Y, Jiang D, Tu C, Wan L, Chen X, et al. Factors associated with duration of viral shedding in adults with COVID-19 outside of Wuhan, China: A retrospective cohort study. *Int J Infect Dis*. 2020;10.1016/j.ijid.2020.05.045.
69. Arons MM, Hatfield KM, Reddy SC, Kimball A, James A, Jacobs JR, et al. Presymptomatic SARS-CoV-2 Infections and Transmission in a Skilled Nursing Facility. *New Engl J Med*. 2020;382(22):2081-90.
70. COVID-19 National Emergency Response Center, Epidemiology and Case Management Team, Korea Centers for Disease Control and Prevention. Coronavirus Disease-19: Summary of 2,370 Contact Investigations of the First 30 Cases in the Republic of Korea. *Osong Public Health Research Perspectives*. 2020;11:81-4.



71. James A, Eagle L, Phillips C, Hedges DS, Bodenhamer C, Brown R, et al. High COVID-19 Attack Rate Among Attendees at Events at a Church - Arkansas, March 2020. *MMWR Morb Mortal Wkly Rep.* 2020;69:632-5.
72. Park SY, Kim Y-M, Yi S, Lee S, Na B-J, Kim CB, et al. Coronavirus Disease Outbreak in Call Center, South Korea. *Emerg Infect Dis.* 2020;26(8).
73. Wei WE, Li Z, Chiew CJ, Yong SE, Toh MP, Lee VJ. Presymptomatic Transmission of SARS-CoV-2 - Singapore, January 23-March 16, 2020. *MMWR Morb Mortal Wkly Rep.* 2020;69(14):411-5.
74. Qian G, Yang N, Ma AHY, Wang L, Li G, Chen X, et al. COVID-19 Transmission Within a Family Cluster by Presymptomatic Carriers in China. *Clin Infect Dis.* 2020;ciaa316.
75. WHO Coronavirus disease 2019 (COVID-19) Situation Report-73. Geneva: World Health Organization; 2020 (available at <https://apps.who.int/iris/handle/10665/331686>).
76. Davies N, Klepac P, Liu Y, Prem K, Jit M, CCMID COVID-19 Working Group, et al. Age-dependent effects in the transmission and control of COVID-19 epidemics. *Nat Med.* 2020; 10.1038/s41591-020-0962-9.
77. Kimball A, Hatfield KM, Arons M, James A, Taylor J, Spicer K, et al. Asymptomatic and presymptomatic SARS-CoV-2 infections in residents of a long-term care skilled nursing facility—King County, Washington, March 2020. *MMWR Surveill Summ.* 2020;69(13):377.
78. Wang Y, Liu Y, Liu L, Wang X, Luo N, Ling L. Clinical outcome of 55 asymptomatic cases at the time of hospital admission infected with SARS-Coronavirus-2 in Shenzhen, China. *J Infect Dis.* 2020;221(11):1770-1774..
79. Byambasuren O, Cardona M, Bell K, Clark J, McLaws M-L, Glasziou P. Estimating the Extent of True Asymptomatic COVID-19 and Its Potential for Community Transmission: Systematic Review and Meta-Analysis (pre-print). *MedRxiv.* 2020 doi: 10.1101/2020.05.10.20097543.
80. Sakurai A, Sasaki T, Kato S, Hayashi M, Tsuzuki S-I, Ishihara T, et al. Natural history of asymptomatic SARS-CoV-2 infection. *N Engl J Med.* 2020;10.1056/NEJMc2013020.
81. Wang Y, Tong J, Qin Y, Xie T, Li J, Li J, et al. Characterization of an asymptomatic cohort of SARS-COV-2 infected individuals outside of Wuhan, China. *Clin Infect Dis.* 2020;ciaa629.
82. Yu P, Zhu J, Zhang Z, Han Y. A Familial Cluster of Infection Associated With the 2019 Novel Coronavirus Indicating Possible Person-to-Person Transmission During the Incubation Period. *J Infect Dis.* 2020;221(11):1757-61.

83. Tong Z-D, Tang A, Li K-F, Li P, Wang H-L, Yi J-P, et al. Potential Presymptomatic Transmission of SARS-CoV-2, Zhejiang Province, China, 2020. *Emerg Infect Dis.* 2020;26(5):1052-4.
84. Koh WC, Naing L, Rosledzana MA, Alikhan MF, Chaw L, Griffith M ea. What do we know about SARS-CoV-2 transmission? A systematic review and meta-analysis of the secondary attack rate, serial interval, and asymptomatic infection (pre-print). *MedRxiv* 2020 doi: 10.1101/2020.05.21.20108746.
85. Heneghan C, E S, Jefferson T. A systematic review of SARS-CoV-2 transmission Oxford, UK: The Centre for Evidence-Based Medicine; 2020 (available at <https://www.cebm.net/study/covid-19-a-systematic-review-of-sars-cov-2-transmission/>)
86. Cheng H-Y, Jian S-W, Liu D-P, Ng T-C, Huang W-T, Lin H-H, et al. Contact Tracing Assessment of COVID-19 Transmission Dynamics in Taiwan and Risk at Different Exposure Periods Before and After Symptom Onset. *JAMA Intern Med.* 2020;e202020.
87. Chaw L, Koh WC, Jamaludin SA, Naing L, Alikhan MF, Wong J. SARS-CoV-2 transmission in different settings: Analysis of cases and close contacts from the Tablighi cluster in Brunei Darussalam (pre-print). *MedRxiv.* 2020 doi: 10.1101/2020.05.04.20090043.
88. Considerations in the investigation of cases and clusters of COVID-19: interim guidance, 2 April 2020. Geneva: World Health Organization; 2020 (available at <https://www.who.int/publications/i/item/considerations-in-the-investigation-of-cases-and-clusters-of-covid-19>).
89. Global surveillance for COVID-19 caused by human infection with COVID-19 virus: interim guidance, 20 March 2020. Geneva: World Health Organization; 2020 (available at <https://www.who.int/publications/i/item/global-surveillance-for-covid-19-caused-by-human-infection-with-covid-19-virus-interim-guidance>).
90. Considerations for quarantine of individuals in the context of containment for coronavirus disease (COVID-19): interim guidance, 19 March 2020. Geneva: World Health Organization; 2020 (available at [https://www.who.int/publications/i/item/considerations-for-quarantine-of-individuals-in-the-context-of-containment-for-coronavirus-disease-\(covid-19\)](https://www.who.int/publications/i/item/considerations-for-quarantine-of-individuals-in-the-context-of-containment-for-coronavirus-disease-(covid-19))).
91. Lauer SA, Grantz KH, Bi Q, Jones FK, Zheng Q, Meredith HR, et al. The Incubation Period of Coronavirus Disease 2019 (COVID-19) From Publicly Reported Confirmed Cases: Estimation and Application. *Ann Int Med.* 2020;172:577-82.



92. Considerations for public health and social measures in the workplace in the context of COVID-19: annex to considerations in adjusting public health and social measures in the context of COVID-19, 10 May 2020. Geneva: World Health Organization; 2020 (available at <https://www.who.int/publications/i/item/considerations-for-public-health-and-social-measures-in-the-workplace-in-the-context-of-covid-19>).

93. Key planning recommendations for mass gatherings in the context of the current COVID-19 outbreak: interim guidance, 29 May 2020. Geneva: World Health Organization; 2020 (available at <https://www.who.int/publications/i/item/10665-332235> ).

94. Infection prevention and control during health care when COVID-19 is suspected: interim guidance, 29 June 2020. Geneva: World Health Organization; 2020 (available at <https://www.who.int/publications/i/item/WHO-2019-nCoV-IPC-2020.4>).

95. Alhazzani W, Møller MH, Arabi YM, Loeb M, Gong MN, Fan E, et al. Surviving Sepsis Campaign: Guidelines on the Management of Critically Ill Adults with Coronavirus Disease 2019 (COVID-19). Crit Care Med. 2020;48(6):e440-e69.

96. Lynch JB, Davitkov P, Anderson DJ, Bhimraj A, Cheng VC-C, Guzman-Cottrill J, et al. Infectious Diseases Society of America Guidelines on Infection Prevention for Health Care Personnel Caring for Patients with Suspected or Known COVID-19. J Glob Health Sci. 2020.

97. United States Centers for Disease Control and Prevention. Interim infection prevention and control recommendations for patients with suspected or confirmed coronavirus disease 2019 (COVID-19) in healthcare settings. Coronavirus Disease 2019 (COVID-19). 2020 (available at <https://www.cdc.gov/coronavirus/2019-ncov/hcp/infection-control-recommendations.html>).

98. European Centre for Disease Prevention and Control. Infection prevention and control and preparedness for COVID-19 in healthcare settings - fourth update. 2020 (available at [https://www.ecdc.europa.eu/sites/default/files/documents/Infection-prevention-and-control-in-healthcare-settings-COVID-19\\_4th\\_update.pdf](https://www.ecdc.europa.eu/sites/default/files/documents/Infection-prevention-and-control-in-healthcare-settings-COVID-19_4th_update.pdf)).

99. Rational use of personal protective equipment for coronavirus disease (COVID-19): interim guidance, 6 April 2020. Geneva: World Health Organization; 2020 (available at [https://www.who.int/publications/i/item/rational-use-of-personal-protective-equipment-for-coronavirus-disease-\(covid-19\)-and-considerations-during-severe-shortages](https://www.who.int/publications/i/item/rational-use-of-personal-protective-equipment-for-coronavirus-disease-(covid-19)-and-considerations-during-severe-shortages)).

WHO continues to monitor the situation closely for any changes that may affect this scientific brief. Should any factors change, WHO will issue a further update. Otherwise, this scientific brief document will expire 2 years after the date of publication.

# Want to read more?

---

Subscribe to newsletter →

**TAB 3**

## AIRBORNE SPREAD OF MEASLES IN A SUBURBAN ELEMENTARY SCHOOL

E. C. RILEY, G. MURPHY AND R. L. RILEY<sup>1</sup>

Riley, E. C. (Russell Rd., Pine Island, Box 312AA, Route 8, Ft. Myers, FL 33901), G. Murphy and R. L. Riley. Airborne spread of measles in a suburban elementary school. *Am J Epidemiol* 107:421-432, 1978.

A measles epidemic in a modern suburban elementary school in upstate New York in spring, 1974, is analyzed in terms of a model which provides a basis for apportioning the chance of infection from classmates sharing the same home room, from airborne organisms recirculated by the ventilating system, and from exposure in school buses. The epidemic was notable because of its explosive nature and its occurrence in a school where 97% of the children had been vaccinated. Many had been vaccinated at less than one year of age. The index case was a girl in second grade who produced 28 secondary cases in 14 different classrooms. Organisms recirculated by the ventilating system were strongly implicated. After two subsequent generations, 60 children had been infected, and the epidemic subsided. From estimates of major physical and biologic factors, it was possible to calculate that the index case produced approximately 93 units of airborne infection (quanta) per minute. The epidemic pattern suggested that the secondaries were less infectious by an order of magnitude. The exceptional infectiousness of the index case, inadequate immunization of many of the children, and the high percentage of air recirculated throughout the school, are believed to account for the extent and sharpness of the outbreak.

epidemiology; infection; measles; measles vaccine; models, theoretical; statistics; vaccination; ventilation

During the spring of 1974, a sharp outbreak of measles occurred in a modern suburban elementary school near Rochester in upstate New York. The epidemic was notable because of its explosive nature and its occurrence in a school where 97 per cent of the children had been vaccinated.

Received for publication June 8, 1977, and in final form December 20, 1977.

Abbreviations: cfm = cubic feet per minute; C/I, ratio of new cases to infectors; m<sup>3</sup>/min = cubic meters per minute.

<sup>1</sup> R. L. Riley: Department of Environmental Health Sciences, The Johns Hopkins University School of Hygiene and Public Health, Baltimore, MD.

Address for reprints: E. C. Riley, M.D., Russell Rd., Pine Island, Box 312AA, Route 8, Ft. Myers, FL 33901.

This work was supported in part by PHS Grants HL-10342 and ES-00454

The authors are indebted to David L. Swift, Ph.D., for assistance in deriving the equations.

We have analyzed the epidemic in terms of the factors that led to the rapid dissemination of infection throughout the school.

*The population at risk.* The school in which the epidemic took place is one of nine schools in a large suburban school district with a total enrollment of over 8100, serving a community of approximately 31,000 people. The study population of 868 children was divided into 36 classes, nine for each of the four grades. There were 204 in kindergarten, 234 in first grade, 201 in second grade, and 229 in third grade. Class size ranged from 20 to 28 children. The kindergarten children attended half-day sessions, four in the morning and five in the afternoon.

*The epidemic pattern.* Measles was introduced into the school by a girl in second grade who became ill on Thursday, April

25th, 1974. Twenty-eight secondary cases followed after an incubation period. The remaining 31 cases occurred either in one spread-out generation or, more probably,

in two generations of 27 and four cases (figure 1). After a total of 60 cases, the epidemic subsided, well before the end of the school year. Since diagnoses were

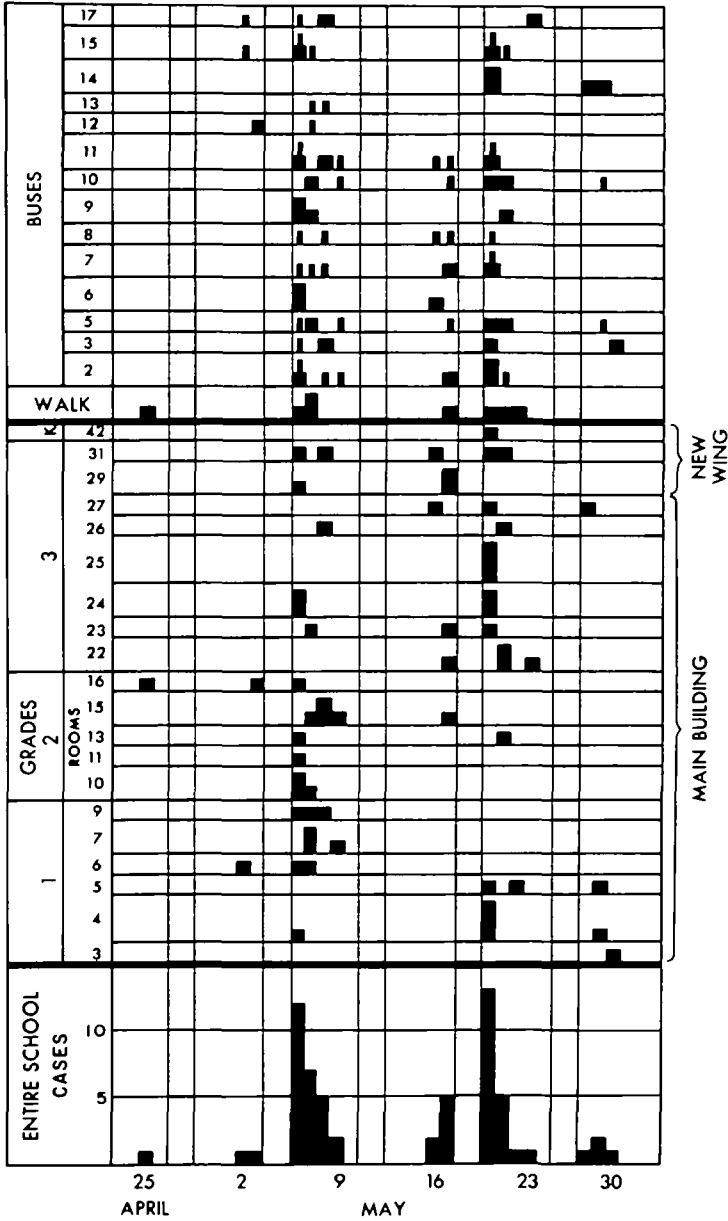

FIGURE 1. Distribution of measles cases in an upstate New York elementary school in spring, 1974, by calendar date of first day of school missed on account of measles. Gray vertical bars identify Saturdays and Sundays. From below up, separated by heavy horizontal lines, cases in entire school; cases by grades and rooms; cases by means of transportation (walk or bus). Cases who traveled one way by bus are shown by narrow vertical bars. On the right the cases with home rooms in the main building and in the new wing are separated because they were supplied by separate ventilating systems.

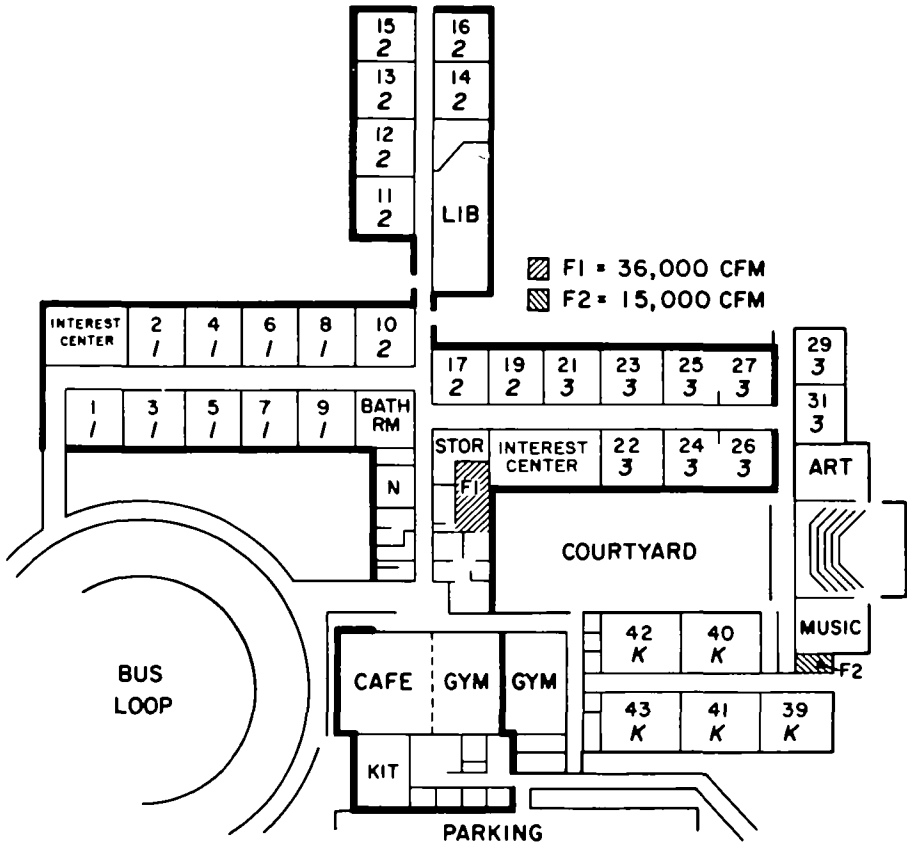

FIGURE 2. Floor plan of an upstate New York elementary school which experienced a measles epidemic in spring, 1974. The main building, constructed in 1961, is outlined in bold lines. F1 identifies the fan room servicing these rooms (36,000 cfm = 1019.4 m<sup>3</sup>/min). The 1971 addition appears to the right and below the courtyard. F-2 identifies its fan room (15,000 cfm = 424.8 m<sup>3</sup>/min). Within the floor area of each room, the room number appears above and the grade below.

based on the clinical signs and symptoms of measles, subclinical cases were not counted.

*Ventilation of the school.* The main part of the school, built in 1961, provided 25 classrooms and was ventilated by one large system with a capacity of 36,000 cubic feet per minute (1019.4 m<sup>3</sup>/min) (figure 2). In 1971, an addition was constructed which provided seven classrooms, two for third grade and five for kindergarten. The new wing was ventilated by a separate system handling about 15,000 cfm (424.8 m<sup>3</sup>/min) of air. Both systems utilized the same type of thermostatic controls which permitted recirculation of air after filtration. The filters for the main

building removed 12 per cent of particles in the respirable range, and the filters in the new wing removed 30 per cent. The amount of outside air added to each system depended on the differential between indoor and outdoor temperatures and was estimated for the period of the epidemic (table 1 and figure 3). The total ventilation (outdoor air plus recirculation) for each classroom was approximately 1000 cfm (28.3 m<sup>3</sup>/min) in the main building and 1200 cfm (34.0 m<sup>3</sup>/min) in the new wing. The cafeteria in the main building received air from the general ventilating system, but air leaving the cafeteria was exhausted to the outdoors.

*The school buses.* Of the 60 children who

TABLE 1

*Estimated amounts of outside air added to two ventilation systems in an elementary school in upstate New York during the period of a measles epidemic, spring, 1974*

Date	Outdoor temperature °F (°C)	Outdoor air ventilation % of total
<i>First Generation</i>		
4/22	64 (17.8)	100
4/23	48 (8.9)	40
4/24	40 (4.4)	28.6
<i>Second Generation</i>		
4/29	70 (21.1)	100
4/30	66 (18.9)	100
5/01	49 (9.4)	42
5/02	49 (9.4)	42
5/03	51 (10.6)	47
5/06	43 (6.1)	32
5/07	40 (4.4)	28.6
5/08	42 (5.6)	30.8
<i>Third Generation</i>		
5/13	49 (9.4)	42
5/14	70 (21.1)	100
5/15	64 (17.8)	100
5/16	54 (12.2)	66.7
5/17	62 (16.7)	100
5/20	51 (10.6)	47
5/21	61 (16.1)	100
5/22	73 (22.8)	100

caught measles, 52 traveled to and from school by bus and eight, including the index case, walked. There were 16 buses, each with 60 seats, except for a few with 66 seats. In order to evaluate the magnitude of infectious exposure in the buses, it was necessary to determine the number and identity of the children on each bus, the duration of exposure, and the approximate rate of ventilation of the bus with outside air. The bus ridden by each child who caught measles was determined from the bus schedules. The time per bus trip ranged from seven to 17 minutes and the average for the 52 bus riders was about ten minutes each way.

Since no accurate information on school bus ventilation was available, special studies were undertaken to determine the dilution with fresh air. The dilution rate

was computed from the washout of an airborne tracer during a simulated bus run complete with stops but with no children on board. During the test run on a snowy December morning all windows were closed and the underseat heaters operating; this condition is typical of operations during much of the school year in this northern community. The dilution rate was determined to be about 250 cfm (7.08 m<sup>3</sup>/min).

*Vaccination histories and serologic data.* Vaccination histories were obtained from school records on 87 per cent of the total school census. The ages at the time of vaccination and the distribution of cases by vaccination history are shown in table 2. This information is not used in our analysis. Serologic data were not available.

#### *Assumptions*

We made the customary assumption that measles is infectious for others during a three-day prodromal period (1). Children whose first day out of school because of measles was Thursday or Friday were considered infectious for others for three days; and those whose first day out was Tuesday or Wednesday were considered infectious for others for one or two days, respectively. Those whose first day out was Monday included those first taken sick on Saturday and Sunday as well as Monday. They were considered to have exposed others for two days because this is the average of three days for those first sick on Saturday, two days for those first sick on Sunday, and one day for those first sick on Monday.

We assumed that measles is exclusively airborne (2) and that infection confers lasting immunity (1), thus removing cases from the pool of susceptibles. We accepted the droplet nucleus hypothesis, which implies the random distribution of infectious particles in the air of enclosed spaces (3). We assumed a steady-state concentration of airborne infection throughout the school day, neglecting the 20- to 45-minute period

of build-up to 95 per cent of equilibrium at the start of school in the morning. We also neglected any biologic decay of airborne measles virus because, under the condi-

tions of ventilation which existed, 99 per cent of virus was vented to the outdoors within an hour, and decay within an hour is believed insignificant (1). Subclinical

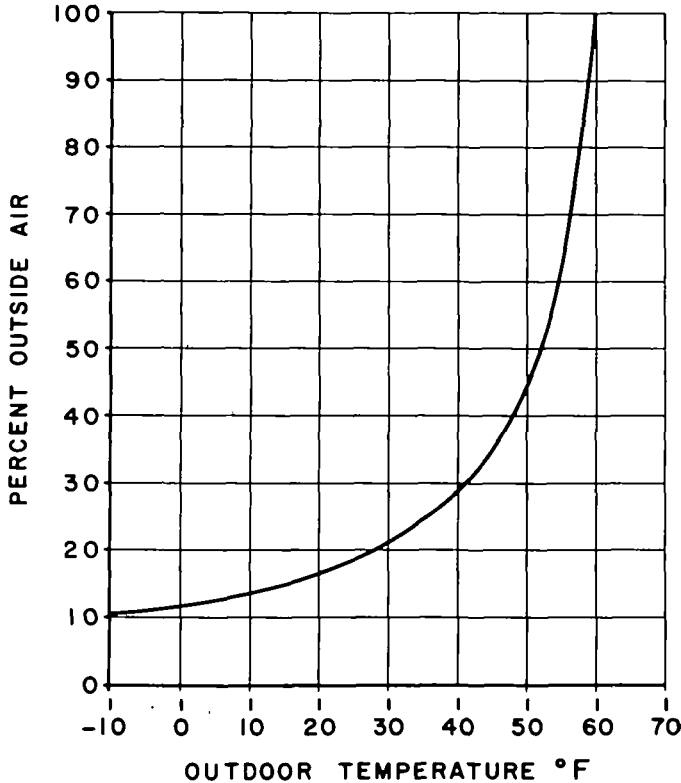

FIGURE 3. Response of the two ventilating systems to changes in outdoor temperature at an upstate New York elementary school which experienced a measles epidemic in spring, 1974. The percentage of recirculated air = 100 minus per cent outside air. This curve is specific for room temperature of 68 F (19 C). For conversion to C: -10 F = -23.3 C; 0 F = -17.8 C; 10 F = -12.2 C; 20 F = -6.7 C; 30 F = -1.1 C; 40 F = 4.4 C; 50 F = 10 C; 60 F = 15.6 C; 70 F = 21.1 C.

TABLE 2

*Ages at time of vaccination and distribution of measles cases by vaccination history in an elementary school in upstate New York in spring, 1974*

Grade	No vaccination or unknown (%) <sup>*</sup>	Age at time of vaccination		
		<1 Year (%)	1 Year (%)	>1 Year (%)
Kindergarten	2.8 (0) <sup>†</sup>	20.3 (1)	45.6 (0)	31.1 (0)
First	1.0 (1)	27.9 (12)	33.2 (4)	37.9 (1)
Second	4.7 (2)	28.4 (9)	26.6 (2)	40.3 (1)
Third	5.2 (3)	31.1 (16)	27.4 (4)	36.3 (4)
Entire school	3.3 (6)	27.0 (38)	33.2 (10)	36.5 (6)
<i>Attack rate</i>				
Entire school	20.9	16.2	3.5	1.9

<sup>\*</sup> Percentage of records reviewed (87 per cent of student population).

<sup>†</sup> ( ) = actual number of cases.



cases were not identified and were, therefore, ignored.

Finally, we assumed the exhaustion of susceptibles, i.e., that the total number of susceptibles at the start of the epidemic was equal to the total number of children infected by the end of the epidemic. This is not a general assumption, applicable to any measles epidemic, but is specifically applicable to the conditions pertaining to the epidemic under consideration. The index case infected no less than 28 secondaries throughout the school. The ratio of new cases to infectors, C/I, has been called by Wells the contagious potential (2) and must exceed unity if a chain reaction, building to an epidemic, is to occur. In the present instance, the ratio C/I had the exceedingly high value of 28. One would, therefore, expect the infectious exposure of the children to increase 28-fold during the second generation, giving the epidemic chain reaction an enormously powerful start. As in the atom bomb, the chain reaction, once started, is very difficult to stop. We have every reason to believe that it did not stop in this epidemic until all susceptibles were infected. Further support for this belief will appear in the analysis which follows.

#### *Major sites of school-related exposure*

From a careful study of the daily curricula of infectious cases and susceptible subjects and the type and amount of ventilation, three important exposure sites were characterized quantitatively: 1) classroom with infector(s); 2) other classrooms served by the same ventilating system; and 3) the school buses.

All of the first, second and third graders ate lunch in the school cafeteria served by the main ventilating system. Cafeteria attendance was scheduled by classes, and the lunch periods were staggered. There was considerable overlapping of lunch periods, increasing the difficulty of quantifying this exposure. Since lunch room exposures were brief, and were probably of

less importance than classroom and bus exposures, we did not include them in the quantitative analysis.

All of the kindergarteners and two third grade classes were assigned rooms in the new wing. The kindergarten children attended half-day sessions and did not use the cafeteria. Although they shared buses with the older children during the morning and afternoon trips, only the kindergarteners were bused at midday. Since the index case walked to school and attended no classes in the new wing, kindergarten exposures were considered to be nil during the first generation of measles.

Third graders' exposures were somewhat mixed. While most sessions were in the main building, two classes were assigned to the new wing which was served by a separate ventilating system. Unlike the kindergarteners, the third graders attended special classes in other rooms and all ate lunch in the school cafeteria. Investigation of the activities of the third graders in rooms 29 and 31 of the new wing indicated that the three who caught measles during the first generation spent about 40 per cent of their time in the main building. During the next generation, these cases contributed organisms to the air of the new wing during 60 per cent of the school day. Other third graders in rooms 29 and 31 spent only about 15 per cent of their time in the main building, and sample calculations suggest that, after the first generation, mixing of children between the main building and the new wing was a minor factor in the pattern of epidemic spread. Home room exposures and bus exposures were much more important, after the first generation, in spreading infection among children in the new wing.

#### *Other possible exposure sites*

There were no general assemblies, but there were probably other exposures both within the school and outside the school which may have affected the pattern of

measles spread. Casual contacts in the hallways and cafeteria and at social functions outside the school were indeterminate, could not be quantified, and have not been included in the analysis.

The mathematical model, to be derived and then applied, is the mathematical expression of the assumptions and the conditions of exposure which have been described, as they pertain to the probability of infection.

MATHEMATICAL MODEL

The model deals with the probability of a susceptible person, *S*, breathing a randomly distributed quantum of airborne infection. A quantum is defined as the number of infectious airborne particles required to infect and may be one or more airborne particles. These particles are so small that they disperse throughout the air of confined spaces in a random manner.

Let *C* = number of cases appearing in the next generation; *I* = number of people in the infectious stage, or infectors; *q* = quanta of airborne infection produced per infector per minute; *p* = pulmonary ventilation rate of each susceptible per minute, in m<sup>3</sup>/min; *Q* = room ventilation rate with germ-free air, in m<sup>3</sup>/min; *Iq* = total quanta produced per minute; and *Iq/Q* = equilibrium concentration of quanta in air in the steady-state.

If quanta of infection were evenly dispersed throughout the air of a confined space, like molecules of a well-mixed gas, then the number of quanta inhaled during a given time would be the concentration (*Iq/Q*) times the volume of air breathed in time *t* (*pt*), or *Iqpt/Q*. Since, in fact, quanta of infection are discrete, randomly distributed, and in very low concentration, the probability, *P*, that a susceptible, *S*, will breathe one or more quanta of infection and thus become a case is:

$$P \text{ of infection} = 1 - e^{-Iqpt/Q} \tag{1}$$

or, if

$$qpt/Q = r \tag{2}$$

$$P \text{ of infection} = 1 - e^{-I^*r^*} \tag{3}$$

The probability of escaping infection in a given environment is  $e^{-I^*r^*}$ . If a susceptible person is exposed to another environment with characteristics  $I^*$  and  $r^*$ , the probability of escaping infection in this environment is  $e^{-I^*r^*}$ . If the two exposures are independent, the probability of escaping infection during both exposures is  $e^{-I^*r^*} \cdot e^{-I^*r^*}$  or  $e^{-(I^*r^* + I^*r^*)}$ . Generalizing to *n* exposures and limiting the exposures to a single generation, we obtain the overall probability that one susceptible will escape infection during one generation:

$$P \text{ of escape during one generation} = e^{-(I_1r_1 + I_2r_2 + \dots + I_n r_n)} \tag{4}$$

and

$$P \text{ of infection during one generation} = 1 - e^{-(I_1r_1 + I_2r_2 + \dots + I_n r_n)} \tag{5}$$

The number of cases, *C*, appearing in the next generation will equal the sum of the individual probabilities of infection over all susceptibles. Hence:

$$C = \sum_{i=1}^S [1 - e^{-(I_1r_1 + I_2r_2 + \dots + I_n r_n)}] \tag{6}$$

$$= \sum S - \sum e^{-I^*r^* \text{ (total)}} \tag{7}$$

Application of the model

For the epidemic under consideration, we know, or can calculate with reasonable accuracy, all the components of equation 7 except *q*, the quanta of infection produced per minute by each infector (*q* is a component of *r*; see equation 2), and  $\sum S$ , the number of susceptibles present at the beginning of the generation in question. For example, the cases appearing in the second generation were all infected by the index case and we know from figure 1 that there were 28 of them. Thus, *C* on the left side of equation 7 = 28. We assume that the total number of cases equals the total number of susceptibles, hence during the first generation  $\sum S = 59$  (60 minus the

index case). The probability of escaping infection must now be estimated for each susceptible individually in order that the sum of these probabilities can appear on the far right of equation 7.

We shall use subscripts 1, 2 and 3 to identify the three major sites of school-related exposure. Subscript 1 will refer to exposures in the same home room ( $I_{1r_1}$ ); subscript 2 to exposure to organisms recirculated through the ventilating system ( $I_{2r_2}$ ); and subscript 3 to exposure to infectious school mates on the same bus ( $I_{3r_3}$ ). The sum of each day's values ( $I_{1r_1} + I_{2r_2} + I_{3r_3}$ ) over the period of a given generation provides the negative exponent for each susceptible, and the value of "e" to this power determines the probability that this susceptible will escape infection.

#### First generation

The components of  $r$  for which reasonable estimates can be made are  $p$ ,  $t$ , and  $Q$ .

$p = 0.00566 \text{ m}^3/\text{min}$  (5.66 liters/min)

$t = 300 \text{ min}$  (one school day of five hours)

The estimation of  $Q$  is carried out as follows. The index case took sick on Thursday, April 25. On April 22 the outdoor temperature was 60 F (15.6 C). There was no recirculation and hence no exposure except in room 16 occupied by the index case (figure 3). On April 23 the outdoor temperature dropped to 48 F (9 C), causing 60 per cent of the air to be recirculated, and on April 24 the temperature was 40 F (4.4 C) with 71.5 per cent recirculation. For these two days  $Q$ , the germ-free air diluting the organisms produced by the index case, was calculated as follows. For 4/23, 40 per cent outside air  $\times 1019.4 \text{ m}^3/\text{min}$  total ventilation = 407.8  $\text{m}^3/\text{min}$  outside air.  $1019.4 - 407.8 = 611.6 \text{ m}^3/\text{min}$  recirculated. Filters removed 12 per cent of particles in the respirable size range, rendering  $.12 \times 611.6 = 73.4 \text{ m}^3/\text{min}$  of recirculated air germ-free. Thus, total germ-free ventilation = 407.8 + 73.4, and  $Q$  for 4/23 = 481.2  $\text{m}^3/\text{min}$ . A similar

calculation for 4/24, when the recirculation was 71.5 per cent, gives:  $Q$  for 4/24 = 378.9  $\text{m}^3/\text{min}$ . Hence,  $r_2$  for 4/23 =  $qpt/Q = q \times .00566 \times 300/481.2 = .00353q$ , and  $r_2$  for 4/24 =  $qpt/Q = q \times .00566 \times 300/378.9 = .00448q$ .

During the first generation the two susceptibles sharing room 16 with the index case were exposed for three days (900 min) in a room ventilated at 28.3  $\text{m}^3/\text{min}$ . For two days they were also exposed to recirculated organisms. Hence

$$\begin{aligned} I_{1r_1} \text{ (home room)} &= q \times .00566 \times 900/28.3 \\ &= .18q \\ I_{2r_2} \text{ (recirculation)} &= .00353q + .00448q \\ &= .008q \text{ and} \\ Ir \text{ (total)} &= .188q \text{ (see table 3).} \end{aligned}$$

Forty-eight susceptibles in the main building were exposed throughout two school days to recirculated organisms only. For them

$$I_{2r_2} = Ir \text{ (total)} = .008q \text{ (see table 3).}$$

Three susceptibles in third grade with home rooms in the new wing spent an estimated 40 per cent of their time in the main building, and five spent an estimated 15 per cent of their time in the main building. Hence, for three susceptibles

$$I_{2r_2} = Ir \text{ (total)} = .40 \times .008q = .0032q, \text{ and for five susceptibles}$$

$$I_{2r_2} = Ir \text{ (total)} = .15 \times .008q = .0012q \text{ (see table 3).}$$

Finally, one susceptible in kindergarten was not exposed at all during the first generation. For this child

$$Ir \text{ (total)} = 0 \text{ (see table 3).}$$

The probability of escaping infection,  $e^{-Ir \text{ (total)}}$ , depends on the value of  $q$ , which is chosen by trial and error to permit 31 susceptibles (59 - 28) to escape infection. When  $q = 93$ , the sum of the probabilities of escaping infection is 30.5 (table 3).

TABLE 3

Values of  $I_r$  during first generation (4/22 through 4/24); probability of escaping infection ( $e^{-I_r}$ ) when  $q = 93$ , during a measles epidemic in an elementary school in upstate New York in spring, 1974

Exposure site	No. $S$ involved	$I_1 r_1$	$I_2 r_2$	$I_3 r_3$	$I_r$ (total)	$e^{-I_r(\text{total})}$ when $q = 93$	$S \dagger$ escaping infection
<i>Main Bldg.</i>							
Rm #16	2	.180 $q$	.008 $q$	0	.188 $q$	$2.55 \times 10^{-9}$	0.000
Other parts	48	0	.008 $q$	0	.008 $q$	0.475	22.800
<i>New Wing</i>							
Rms #29, 31	3*	0	.0032 $q$	0	.0032 $q$	0.743	2.228
	5†	0	.0012 $q$	0	.0012 $q$	0.894	4.472
Rm for Kindergarten	1	0	0	0	0	1.000	1.000
						$\sum e^{-I_r(\text{total})} = 30.500$	

\* Exposed 40 per cent of time in main building ( $.40 \times .008q = .0032q$ ).

† Exposed 15 per cent of time in main building ( $.15 \times .008q = .0012q$ ).

‡ Susceptibles escaping =  $e^{-I_r(\text{total})} \times \text{no. } S \text{ involved}$ .

$$C = \sum S - \sum e^{-I_r(\text{total})}$$

$$C = 59 - 30.5$$

$$C = 28.5 \text{ cases predicted in second generation.}$$

Hence, according to the model, the index case produced quanta of airborne infection at a rate of 93 quanta per minute. When  $q = 93$ , 28.5 cases are predicted in the second generation, in conformity with the epidemiologic observation.

### Second generation

The model can now be applied to susceptibles exposed in the second generation and becoming cases in the third generation. In this instance there were 28 infectors,  $I$ , and 31 remaining susceptibles,  $\sum S$ . Each of the 31 susceptibles has to be dealt with separately because of the great variety of exposure histories. An illustration will show the procedure which was carried out for each. The case chosen (#34, room 15, bus 5 one way, but 10 the other way) was the most heavily exposed (smallest chance of escaping infection) of any child in the school.

On Monday, May 6, everyone in room 15, including #34, was exposed to measles disseminated by four infectious classmates, one of whom was taken sick on Tuesday, two on Wednesday, and one on Thursday (figure 1). All were presumably in the infectious stage on Monday. Thus,

$$I_1 r_1 = (qpt/Q)I_1 = (q \times .00566 \times 300/28.3) \times 4 = .240q.$$

On this same Monday, #34 breathed recirculated air contaminated by 13 children in the infectious stage in the main building and one third grader in the new wing (room 31) who, as mentioned above, spent an estimated 40 per cent of his time in the main building. Hence,  $I_2 = 14$ . The outside temperature was such that germ-free  $Q$ , calculated as above, was 409.4 m<sup>3</sup>/min for the entire main building. Thus,

$$I_2 r_2 = (qpt/Q)I_2 = (q \times .00566 \times 300/409.4) \times 14 = .058q.$$

On Monday, May 6, #34 came to school and returned home on two different buses. During the ten minute ride in each direction, there were three children in the infectious stage. Thus  $I_3 = 3$ .  $Q$  for each bus was 7.08 m<sup>3</sup>/min. Hence,

$$I_3 r_3 = (qpt/Q)I_3 = (q \times .00566 \times 10/7.08) \times 3 = .024q$$

for one bus ride. Total  $I_3 r_3$  for rides in both directions = .048 $q$ .

The chance that case #34 escaped infection on Monday, May 6, was

$$e^{-(I_1 r_1 + I_2 r_2 + I_3 r_3)} = e^{-(.240q + .058q + .048q)} = e^{-.346q}$$

## DISCUSSION

However, May 6 was but one of six days during which this child was exposed during the second generation of the epidemic (figure 1). The total cumulative value of  $I_r$  for #34 was .745 $q$  (table 4).

This procedure was carried through for each of the 31 susceptibles (table 5). If it is assumed that each of the 28 infectors produced quanta of infection at a rate of 93 per minute like the index case, the corresponding values of  $e^{-I_r}$  can be calculated for each of the 31 susceptibles. The sum of these 31 probabilities of escaping infection is  $< .0001$ , indicating a probability of less than one in ten thousand that any susceptible would escape infection during the second generation (table 5,  $q = 93$ ).

This conclusion conflicts with the inference from inspection of figure 1 that some or all of the last four cases represented a fourth generation. If this inference is correct, four susceptibles must have escaped infection during the second generation, and the sum of the values of  $e^{-I_r}$  in table 5 should have equaled 4 rather than  $< .0001$ . By trial and error it is found that if  $q = 8$ , 4.6 susceptibles would have escaped infection in the second generation and thus have been available to be cases in a fourth generation (table 5,  $q = 8$ ).

These calculations suggest that the index case may have been exceptionally infectious and that the secondaries may have been, on the average, only about one tenth as infectious. The findings define the probable range of  $q$  values as  $8 < q < 93$ .

The model which we have presented is capable of accepting as much detail as is warranted by the information at hand. Analysis of the sites of exposure which we have omitted could have been included if the necessary observations and measurements had been available.

In applying a model to simulate an epidemic, the assumption is ordinarily made that the average infectiousness of all cases is the same (3). If this is done for the epidemic under consideration and a  $q$  of 93 applied throughout, the conclusion is reached that all remaining susceptibles were infected in the second generation, making the third generation the last. Even if the total number of susceptibles had been 100 instead of 60, the 28 children infected by the index case would have exhausted susceptibles in the next generation. Since the last case took sick three weeks after the last day of infectious exposure in the second generation, it could be argued that this case and the other three stragglers simply had unusually long incubation periods. We question this interpretation because inspection of the epidemic pattern suggests that the last four cases (or at least some of them) probably constituted a fourth generation with the more probable incubation period of about 10 days (figure 1). In order to prevent premature exhaustion of susceptibles in the second generation, the model re-

TABLE 4

*Cumulative exposure pattern of case #34 in a measles epidemic in an elementary school in upstate New York in spring, 1974*

Case	Days during epidemic						Sum
	5/1	5/2	5/3	5/6	5/7	5/8	
#34 $I_1 r_1$	—	—	—	.240 $q$	.180 $q$	.060 $q$	.480 $q$
Rm #15 $I_2 r_2$	.007 $q$	.037 $q$	.031 $q$	.058 $q$	.027 $q$	.009 $q$	.169 $q$
$I_3 r_3$	—	.008 $q$	.008 $q$	.048 $q$	.016 $q$	.016 $q$	.096 $q$
	.007 $q$	.045 $q$	.039 $q$	.346 $q$	.223 $q$	.085 $q$	.745 $q$ *

\* Grand total of  $I_r$  contributions from different sources and different days.

TABLE 5

Values of  $I_r$  during second generation (4/29 through 5/8); probability of escaping infection ( $e^{-I_r}$ ) when  $q = 93$  and when  $q = 8$ , during a measles epidemic in an elementary school in upstate New York in spring, 1974

S#	Rm#	$I_{r_1}$	$I_{r_2}$	$I_{r_3}$	$I_r$ (total)	$e^{-I_r(\text{total})}$ when	
						$q = 93$	$q = 8$
30	31	.2q	.042q	.112q	.354q	$5.0 \times 10^{-18}$	.059
31	27	0	.165q	.128q	.293q	$1.5 \times 10^{-12}$	.094
32	29	.1q	.042q	.168q	.310q	$3.0 \times 10^{-13}$	.084
33	22	0	.165q	.080q	.245q	$1.3 \times 10^{-10}$	.141
34	15	.48q	.165q	.096q	.745q	$8.1 \times 10^{-31}$	.003
35	23	.06q	.165q	.120q	.285q	$3.1 \times 10^{-12}$	.102
36	29	.1q	.042q	0	.142q	$1.8 \times 10^{-6}$	.321
37	4	.12q	.165q	0	.285q	$3.1 \times 10^{-12}$	.102
38	5	0	.165q	.112q	.277q	$6.5 \times 10^{-12}$	.109
39	42	0	.021q	.080q	.101q	$8.3 \times 10^{-8}$	.446
40	4	.12q	.165q	0	.285q	$3.1 \times 10^{-12}$	.102
41	4	.12q	.165q	.168q	.453q	$5.1 \times 10^{-19}$	.027
42	24	.24q	.165q	0	.405q	$4.4 \times 10^{-17}$	.039
43	25	0	.165q	.096q	.261q	$2.9 \times 10^{-11}$	.124
44	27	0	.165q	.096q	.261q	$2.9 \times 10^{-11}$	.124
45	31	.2q	.042q	.096q	.339q	$2.0 \times 10^{-14}$	.066
46	25	0	.165q	.168q	.333q	$3.6 \times 10^{-14}$	.070
47	23	.06q	.165q	.168q	.393q	$1.3 \times 10^{-16}$	.043
48	25	0	.165q	.168q	.333q	$3.6 \times 10^{-14}$	.070
49	24	.24q	.165q	.080q	.485q	$2.6 \times 10^{-20}$	.021
50	26	.12q	.165q	0	.285q	$3.1 \times 10^{-12}$	.102
51	22	0	.165q	.096q	.261q	$2.9 \times 10^{-11}$	.124
52	13	.12q	.165q	.160q	.445q	$1.1 \times 10^{-16}$	.028
53	22	0	.165q	.096q	.261q	$2.9 \times 10^{-11}$	.124
54	31	.20q	.042q	.168q	.410q	$2.8 \times 10^{-17}$	.038
55	5	0	.165q	0	.165q	$2.2 \times 10^{-7}$	.267
56	22	0	.165q	.144q	.309q	$3.3 \times 10^{-13}$	.085
57	27	0	.165q	0	.165q	$2.2 \times 10^{-7}$	.267
58	4	.12q	.165q	.096q	.381q	$4.1 \times 10^{-16}$	.047
59	5	0	.165q	0	.165q	$2.2 \times 10^{-7}$	.267
60	3	0	.165q	.096q	.261q	$2.9 \times 10^{-11}$	.124
						$\sum e^{-I_r(\text{total})} = 8.5 \times 10^{-6}$	4.620
						$= < 0.0001$	

$$C = \sum_{i=1}^{S=31} [1 - e^{-I_r(\text{total})}]$$

$$C = \sum S - \sum e^{-I_r(\text{total})}$$

$$C = 31 - (<.0001) = 30.9999+ \quad \text{when } q = 93$$

$$C = 31 - 4.62 = 26.38 \quad \text{when } q = 8$$

cases predicted in third generation.

quires that  $q$  be decreased from 93 to 8 (table 5).

We are intrigued by the possibility of an order of magnitude difference between the infectiousness of the index case and the subsequent cases. The index case may truly have been a disseminator, a case that produced an exceptional amount of

airborne virus (4). This, together with cool weather causing a high percentage of air to be recirculated throughout the school, apparently provided the combination of circumstances required to account for the sharp outbreak.

The equilibrium concentration of recirculated quanta of infection can be calcu-

lated since we know the rate at which quanta were added and the volume of air in which this number of quanta was vented. For example, if on April 23rd 93 quanta per minute were vented in 481.2 m<sup>3</sup> of air per minute, one quantum was dispersed in 481.2/93 or 5.17 m<sup>3</sup>. Thus, even the highly infectious index case caused only one quantum of infection per 5.17 m<sup>3</sup> of air to be distributed throughout the main building of the school because of the enormous dilution of airborne particles by school ventilation. Since in a school day of 300 minutes a child breathes about 300 × .00566 or 1.7 m<sup>3</sup> of school air, there was a good chance that any given child would not become infected. During the second generation there were 28 infectors. The concentration of quanta in the air must have been higher (using either  $q = 93$  or  $q = 8$ ) and the infectious period was about three times as long as in the first generation (figure 1). There was thus much less likelihood that anyone would escape infection.

The measles attack rates show the expected decline with age at time of vaccination (table 2), indicating increasing effectiveness of vaccination. The 20.9 per cent attack rate in children with no vaccination or unknown vaccination history suggests that most of those with unknown history had in fact been immunized since a higher attack rate would be expected in unvaccinated children who had never had measles. In the other groups, the attack rates are in the range of expected vaccination failures (5, 6), supporting our belief that the number of children attacked included all who were susceptible.

With knowledge of the school ventilation system and of the activities and whereabouts of the school children, we were able to use the mathematical model to make computations which were compatible with the observed epidemic pattern and which gave measures of the relative importance of the three major sites of school-related exposure ( $I_{1r_1}$ ,  $I_{2r_2}$ ,  $I_{3r_3}$ ).

During the first generation, spread from the index case was obviously dominated by the recirculation system ( $I_{2r_2}$ ) except in room 16 (table 3). In the second generation as well, exposure from virus in recirculated air ( $I_{2r_2}$ ) was often greater than home room exposure ( $I_{1r_1}$ ) or bus exposure ( $I_{3r_3}$ ) (table 5).

In view of the widespread use of recirculating systems in schools, hospitals, hotels and office buildings, the possibility of sterilizing recirculated air should be explored. This can be accomplished by high intensity ultraviolet irradiation in central supply ducts (7-9). Although air disinfection in ducts would not prevent spread of infection in classrooms containing an infector ( $I_{1r_1}$ ) or in outside locations ( $I_{3r_3}$ ), it could eliminate exposure from recirculated organisms ( $I_{2r_2}$ ). Our analysis indicates that this would slow the rate and change the pattern of spread. The present epidemic would probably have been aborted.

#### REFERENCES

1. Langmuir AD: Contagious disease spread largely from the mouth and nose. *In* Rosenau Preventive Medicine and Hygiene. Seventh edition. Maxcy KF, editor. Chapter 1. New York, Appleton-Century-Crofts, 1951
2. Wells WF: Threshold sanitary ventilation. *In* Airborne Contagion and Air Hygiene. Chapter 14. Cambridge, MA, Harvard University Press, 1955
3. Riley RL, O'Grady F: Epidemiology of airborne infection. *In* Airborne Infection: Transmission and Control. Chapter 6. New York, Macmillan, New York, 1961
4. Sultan L, Nyka W, Mills CC, et al: Tuberculosis disseminators. *Am Rev Respir Dis* 82:358-369, 1960
5. Linnemann CC, Jr, Totte TC, Schiff GM, et al: A seroepidemiologic study of a measles epidemic in a highly immunized population. *Am J Epidemiol* 95:238-246, 1972
6. Shasby DM, Shope TC, Downs H, et al: Epidemic measles in a highly vaccinated population. *New Engl J Med* 296:585-589, 1977
7. Hoffman JC, Nagy R: Air sanitation with ultraviolet light. *Air Engineering*, October, 30-36, 1960
8. Hoffman JC, Nagy R: Air sanitation with ultraviolet light. *Air Engineering*, November, 43-46, 1960
9. Buttolph LJ, Haynes H: Ultraviolet Air Sanitation. Cleveland, OH, General Electric Engineering Division, Lamp Department, LD-11, revised January, 1950

**TAB 4**



## Review Article

# Role of ventilation in airborne transmission of infectious agents in the built environment – a multidisciplinary systematic review

**Abstract** There have been few recent studies demonstrating a definitive association between the transmission of airborne infections and the ventilation of buildings. The severe acute respiratory syndrome (SARS) epidemic in 2003 and current concerns about the risk of an avian influenza (H5N1) pandemic, have made a review of this area timely. We searched the major literature databases between 1960 and 2005, and then screened titles and abstracts, and finally selected 40 original studies based on a set of criteria. We established a review panel comprising medical and engineering experts in the fields of microbiology, medicine, epidemiology, indoor air quality, building ventilation, etc. Most panel members had experience with research into the 2003 SARS epidemic. The panel systematically assessed 40 original studies through both individual assessment and a 2-day face-to-face consensus meeting. Ten of 40 studies reviewed were considered to be conclusive with regard to the association between building ventilation and the transmission of airborne infection. There is strong and sufficient evidence to demonstrate the association between ventilation, air movements in buildings and the transmission/spread of infectious diseases such as measles, tuberculosis, chickenpox, influenza, smallpox and SARS. There is insufficient data to specify and quantify the minimum ventilation requirements in hospitals, schools, offices, homes and isolation rooms in relation to spread of infectious diseases via the airborne route.

**Y. Li<sup>1</sup>, G. M. Leung<sup>2</sup>, J. W. Tang<sup>3</sup>,  
X. Yang<sup>4</sup>, C. Y. H. Chao<sup>5</sup>, J. Z. Lin<sup>6</sup>,  
J. W. Lu<sup>7</sup>, P. V. Nielsen<sup>8</sup>, J. Niu<sup>9</sup>,  
H. Qian<sup>1</sup>, A. C. Sleight<sup>10</sup>, H.-J. J. Su<sup>11</sup>,  
J. Sundell<sup>12</sup>, T. W. Wong<sup>13</sup>,  
P. L. Yuen<sup>14</sup>**

Departments of <sup>1</sup>Mechanical Engineering and <sup>2</sup>Community Medicine, The University of Hong Kong, Pokfulam, Hong Kong, <sup>3</sup>Department of Microbiology, The Chinese University of Hong Kong, Shatin, Hong Kong, <sup>4</sup>Department of Building Science and Technology, Tsinghua University, Beijing, China, <sup>5</sup>Department of Mechanical Engineering, The Hong Kong University of Science and Technology, Hong Kong, <sup>6</sup>Division of Building Science and Technology and <sup>7</sup>Department of Building and Construction, City University of Hong Kong, Hong Kong, China, <sup>8</sup>Department of Civil Engineering, Aalborg University, Aalborg, Denmark, <sup>9</sup>Department of Building Services Engineering, The Hong Kong Polytechnic University, Hong Kong, China, <sup>10</sup>National Centre for Epidemiology and Population Health, Australian National University, Canberra, Australia, <sup>11</sup>Medical College, National Cheng Kung University, Tainan, Taiwan, <sup>12</sup>International Centre for Indoor Environment and Energy, Technical University of Denmark, Copenhagen, Denmark, <sup>13</sup>Department of Community and Family Medicine, The Chinese University of Hong Kong, Shatin, Hong Kong, <sup>14</sup>Hospital Authority, Hong Kong SAR Government, Hong Kong, China

Key words: Airborne; Transmission; Ventilation; Outbreak; Airflow; Building.

Dr Yuguo Li  
Department of Mechanical Engineering  
The University of Hong Kong  
Room 7-2, Haking Wong Building  
Pokfulam Road  
Hong Kong SAR  
China  
Tel.: (+852) 2859 2625  
Fax: (+852) 2858 5415  
e-mail: liyg@hku.hk

Received for review 14 March 2006. Accepted for publication 14 March 2006.

© Indoor Air (2006)

**Practical Implication**

The strong and sufficient evidence of the association between ventilation, the control of airflow direction in buildings, and the transmission and spread of infectious diseases supports the use of negatively pressurized isolation rooms for patients with these diseases in hospitals, in addition to the use of other engineering control methods. However, the lack of sufficient data on the specification and quantification of the minimum ventilation requirements in hospitals, schools and offices in relation to the spread of airborne infectious diseases, suggest the existence of a knowledge gap. Our study reveals a strong need for a multidisciplinary study in investigating disease outbreaks, and the impact of indoor air environments on the spread of airborne infectious diseases.

**Introduction**

The emergence of severe acute respiratory syndrome (SARS) in 2002–03, the global resurgence of tuberculosis (TB) during the last decade, the growing threat of deliberately released agents such as anthrax, and concerns about a highly pathogenic influenza pandemic serve as timely reminders that airborne infectious diseases remain a serious threat to human health. Moreover, the dense contact networks that characterize urban cities form an ideal basis for rapid and uncontrolled disease propagation, especially by the airborne route of spread (Eubank et al., 2004; Weiss and McMichael, 2004). For instance, SARS originated in the rural Guangdong Province in China in November 2002 (Zhong et al., 2003), but was exported to the rest of the world via the densely populated city of Hong Kong in March 2003 (Guan et al., 2004). As in 2000, there were 17 megacities (> 10 million population) and 22 large metropolitan areas (5–10 million population) globally (Zwingle, 2002). At the same time, people in developed countries/regions spend more than 90% of their time indoors in homes, offices, schools, vehicles, airplanes, etc. We therefore carried out a systematic review of the role of the built environment in the transmission of airborne infectious agents. Specifically, we examined whether there was sufficiently strong evidence in the current literature to substantiate a contributory role of ventilation rates and airflow patterns in the airborne transmission of infectious agents in different indoor settings.

To study the airborne spread of infectious agents, some precise definitions are required. For the purposes of this review, we adopted the following:

- Airborne transmission refers to the passage of microorganisms from a source to a person through aerosols, resulting in infection of the person with or without consequent disease.
- Aerosols are a suspension of solid or liquid particles in a gas, with particle size from 0.001 to over 100  $\mu\text{m}$  (Hinds, 1982).
- A droplet nucleus is the airborne residue of a potentially infectious (microorganism bearing) aerosol from which most of the liquid has evaporated (Wells, 1934).

The airborne transmission route of infectious diseases has been reviewed by Langmuir (1961) in general, Mangili and Gendreau (2005) for commercial air travel, Aitken and Jeffries (2001), Beggs (2003), Cole and Cook (1998) and Church (1986) for hospitals, Strausbaugh et al. (2003) for nursing homes, Goldmann (2000) for homes, and Bates and Nardell (1995) for TB. Historically, the concept of airborne spread was first described in detail by Wells (1934, 1955) and Riley and O'Grady (1961), culminating in the well-known Wells–Riley equation (Riley et al., 1978) for evaluating the effect of ventilation, filtration and other physical processes on the transmission of airborne diseases (Fennelly and Nardell, 1998; Nardell et al., 1991), although its exact scientific basis has remained controversial. When an infected individual sneezes, coughs or talks, germ-laden droplets are released. The majority of these are < 100  $\mu\text{m}$  in diameter (Duguid, 1945; Papineni and Rosenthal, 1997), and these evaporate rapidly in the surrounding environment (Wells, 1934) and become droplet nuclei, which suspend in the air or are transported away by room airflow. Droplets larger than 100  $\mu\text{m}$  can fall to the floor within 1 m of the source patient or evaporate on surfaces (forming fomites), and perhaps later become resuspended into the air. Here, we restrict our attention to source-to-person airborne transmission, without an intermediate non-air medium such as fomites.

Ventilation refers to the process of introducing and distributing outdoor and/or properly treated recycled air into a building or a room (Etheridge and Sandberg, 1996). The amount of outdoor air circulated per unit time is termed the ventilation rate, whereas its distribution refers to the pattern of air movement within a room or between rooms in a building. The ventilation process can involve airflow by either natural forces such as thermal buoyancy and wind, or by fan force. Air movement can also be controlled by air-conditioning (through recirculation of exhaust air, momentum and buoyancy) and can be affected by physical barriers in a building or movement of people, and so on. The main objectives of room or building ventilation include health, thermal comfort and productivity (ASHRAE, 2004; Fisk and Rosenfeld, 1997). While most literature focuses on environmental health effects of ventilation rates (Berglund et al., 1992; Daisey et al., 2003; Letz,

1990; Rossi et al., 1991; Seppanen et al., 1999; Sundell, 2004; Wargocki et al., 2002), particularly concerning building-related illnesses (Kroenke, 1998; Menzies and Bourbeau, 1997) or sick building syndrome (Kreiss, 1990; Redlich et al., 1997; Sherin, 1993), little is known about the impact of airflow patterns on infectious disease propagation.

We address the following two specific research questions in this review:

- 1 Is there sufficient evidence to support that the ventilation rate and/or the airflow pattern are contributing cause(s) for the spread of airborne infectious diseases?
- 2 If so, is there good evidence/data to support the specification and quantification of minimum ventilation requirements to minimize the transmission of airborne infectious diseases in different settings (nosocomial or otherwise)?

## Methods

A multidisciplinary consensus panel comprising experts in medicine and public health (three epidemiologists, one virologist and two environmental health specialists) and engineering (five in the area of ventilation and indoor air quality, two in air purification and disinfection, and one in hospital engineering) was convened. Each selected article was assessed in detail according to a set of predefined benchmarks by at least one medical and one engineering specialist from the panel. These detailed assessments were subsequently compiled, circulated and further considered by the entire panel. We adopted a modified Delphi approach by e-mail circulation and telephone communication over a 2-month period, which concluded with a 2-day consensus meeting held in Hong Kong in September 2005.

To identify relevant articles in the literature, we systematically searched the following electronic databases: MEDLINE (1965 to March 2005), ISI Web of Knowledge (1970 to March 2005) and ScienceDirect (1960 to March 2005) using a predetermined list of various combinations and permutations of the following keywords or medical subject headings (MeSH): ventilation, airflow, airborne, droplet, droplet nuclei, aerosol, bioaerosol, transmission, survival, infectivity, nosocomial, tuberculosis, measles, influenza, varicella, smallpox, SARS, common cold, anthrax, respiratory, inhaled, and communicable diseases. We also reviewed the bibliography of retrieved articles to identify other references that might not otherwise have been identified. Only original articles in English were considered. The other inclusion criterion was the relevance of the article to the two key research questions identified above. Conference papers and abstracts were excluded, as were purely descriptive articles without an explicit detailed analytic component. We excluded work in this area before 1960, as this had already been comprehen-

sively reviewed (Riley and O'Grady, 1961; Wells, 1955). There were also difficulties in accessing some of these early papers. When interpreting these criteria, two independent reviewers rated the relevance of the article dichotomously and disagreement was settled by consensus, while taking a deliberately liberal bias to minimize selection or inclusion bias, i.e. higher sensitivity at the expense of specificity.

Once the identified articles had been screened by the inclusion and exclusion criteria, the panel then evaluated the content of each of the final set of papers in relation to the two key research questions. More specifically, when considering the possible contributory roles of ventilation rate and/or airflow pattern in relation to airborne transmission of infectious agents, we assumed that fulfillment of any one of the following conditions indicated evidentiary support:

- 1 An outbreak of an airborne disease occurred that could be directly attributed to a lack of outdoor air into and circulation within an enclosed space (Wells, 1955).
- 2 The incidence of airborne infection in susceptible hosts was inversely associated with the ventilation rate per person (Wells, 1955).
- 3 An outbreak of an airborne disease in an enclosed space occurred that was due to the air transport of infectious droplet nuclei from one location to another location spatially that was further than a droplet could have been spread naturally via an infected individual's respiratory tract alone.

Each panel member was asked to consider these criteria when rating the findings of each study on a three-point Likert scale (i.e. 'failed to meet the evidentiary threshold or non-conclusive', 'somewhat met the evidentiary threshold or partly conclusive' or 'clearly met the evidentiary threshold or conclusive'). The methodological rigor and the overall quality of each study/article were also assessed on a three-point scale (i.e. 'unsatisfactory', 'average' or 'good'). We did not specify *a priori* standard methodological approaches that would have been acceptable and remained open-minded, given the early stage of development of this field of enquiry. The only criterion was that the research techniques employed must have been scientifically robust, repeatable and reliable. In cases where none of the members had sufficient technical expertise to judge the methodological robustness of a study, we were prepared to co-opt outside experts as necessary, although this situation did not occur. Finally, each panel member was asked to identify future research needs in the area of each particular study.

## Results

A large number of papers were initially identified through an electronic search, of which 183 remained

after applying the inclusion and exclusion criteria. After a further round of selection by focusing on articles that dealt with airborne diseases, and with information on ventilation and airflows, 40 studies (a total of 45 papers) were included for detailed review (Table 1).

#### Overall assessment

Of the 40 studies, 18 were considered as non-conclusive or not having met the evidentiary threshold to support a direct contributory role of ventilation rate/airflow pattern to the airborne spread of infectious agents, 12 were considered partly conclusive or met the threshold somewhat, and 10 were deemed clearly conclusive as supporting a direct contribution. Taking an overall perspective, we believe that there is a strong and sufficient evidence in the current literature to demonstrate a definite association between ventilation and airflow patterns in the indoor environment and the transmission of infectious diseases. Responsible agents cited include measles, TB, chickenpox, influenza, smallpox and SARS.

Most studies involve the description of a single index case with secondary cases possibly arising from the index case. On the airflow side, there is some attempt to connect the index and the secondary cases using some kind of experimental or mathematical airflow studies such as tracer gas techniques, smoke visualization or computational fluid dynamics (CFD) simulations. Usually, the ventilation and airflow component of each study is quite poor and hence there are many partly or non-conclusive studies. Of the 40 studies, 18 involve TB, of which 11 are non-conclusive, three are partly conclusive, and only three are conclusive. In many studies, such as Breathnach et al. (1998), only descriptive information on ventilation is given. On the other hand, most of the TB studies use tuberculin skin reactivity to signify exposure, but such skin reactivity is not specific for a particular strain of TB, i.e. the reactor may have been exposed to another source of TB at around the same time, despite having a similar tuberculin skin reaction, as the other linked secondary cases.

Among the 12 studies that were partly conclusive or met the threshold somewhat, three were on TB outbreaks (Calder et al., 1991; Edlin et al., 1992; Ehrenkranz and Kicklighter, 1972), three were on SARS outbreaks (Li et al., 2005a,b; Olsen et al., 2003; Yu et al., 2004), two were on measles outbreaks (Remington et al., 1985; Riley et al., 1978), and four studies were on chickenpox, anthrax, rhinovirus, and methicillin-resistant *Staphylococcus aureus*, respectively. The studies by Yu et al. (2004) and Li et al. (2005b) on the Amoy Gardens Block E SARS outbreak did not present any experimental measurements. Although the epidemiological evidence of airborne transmission is strong, the panel was not convinced

with the computer airflow simulation alone. The same argument also applied to the studies of Remington et al. (1985) and Meselson et al. (1994). The ventilation data in Leclair et al. (1980) was incomplete, although the epidemiological evidence was strong for airborne transmission. The study of an aircraft SARS outbreak by Olsen et al. (2003) showed that the spatial distribution of the secondary infection was beyond the possibility of large droplet transmission alone, which means that transmission was either before boarding or via an airborne route on board. There was no study carried out on airflow patterns in the aircraft cabin. The studies by Meselson et al. (1994) and Yu et al. (2004) are striking, as they showed how the virus-laden aerosols could spread a few kilometers in a city or between buildings that are 60 m apart, due to wind flows. In the TB studies, the difficulties in ruling out other transmission routes such as direct contact and large droplets are obvious.

We observed a tendency that most of the studies that somewhat met the evidentiary threshold were conducted by investigators from a single discipline (usually engineering or medicine), whereas multidisciplinary investigative teams using a more comprehensive and sophisticated set of techniques often scored higher on this assessment criterion (i.e. clearly met the evidentiary threshold). In most of these studies, a floor/section plan of the buildings where the outbreak occurred and a sketch of the ventilation system design would be very useful to demonstrate the impact of the air environment.

There was, however, insufficient data to specify and quantify the minimum ventilation requirements in any setting, including in nosocomial environments such as hospitals and even more so in schools, offices and other buildings, in relation to the spread of infectious diseases via the airborne route.

#### Role of ventilation rates

Among the 10 studies considered to be conclusive, five specifically examined the role of ventilation rates, i.e. Hoge et al. (1994), Menzies et al. (2000), Moser et al. (1979), Riley et al. (1962), and Schulman and Kilbourne (1962).

The latter two studies are case-control animal experimental studies for human diseases. Riley et al. (1962) used guinea pigs, while Schulman and Kilbourne (1962) used mice. In Riley et al. (1962), air from a TB ward delivered to an exposure chamber caused 63 infections, while no infection was observed in a different control chamber with UV-irradiated air delivery. This study also proved the infectivity of exhaust air from a TB ward. The approach of Schulman and Kilbourne (1962) is unique, in that infected mice with A2 (Asian) influenza virus placed in a cage were found to transmit the virus to non-infected

**Table 1** Summary of the 40 studies (totaling 45 papers) between 1960 and March 2005 included in the systematic review

Study no.	Reference	Methods		Main results	Methodological quality/overall quality of the studies	Findings in relation to the evidentiary threshold	Remarks		
		Setting (infectious agent)	Epidemiologic						
1	Bloch et al. (1985)	Pediatric office suite (measles)	Epidemiologic and airflow studies	Airflow	Use of smoke puffs to determine flow pattern and tracer aerosols to determine droplet nuclei dispersion	Droplet nuclei generated in one room with index patient dispersed into the 200 m <sup>2</sup> pediatric office suite with two separately mechanically ventilated zones; at least three cases were confirmed to be infected by airborne route	Good/good	Conclusive	Air circulation rate was about 4 ACH, but outdoor airflow rate unknown; no discussion on the air exchange between the two separately ventilated zones
2	Breathnach et al. (1998)	Hospital (MRTB)	Epidemiologic study with limited airflow measurement	Airflow	Only claimed that 'the isolation rooms in ward 1 were positive pressure relative to the main ward'	HIV-negative patient with MDRTB stayed in a positive pressure isolation room in Ward 1; seven other HIV-positive patients developed MDRTB	Unsatisfactory/unsatisfactory	Non-conclusive	Hospital staff were unaware that the isolation rooms built 20 years ago were at positive pressure for fire protection; very limited information on ventilation
3	Calder et al. (1991)	Health clinic (TB)	Case-control study with limited ventilation measurement	Airflow	Both total and fresh air change rates, CO <sub>2</sub> levels were measured	TB patient receiving aerosolized pentamidine treatments in a positively pressurized room infected 30 of 76 staff members	Average/average	Partly conclusive	The ventilation rates in the two floors were <0.6 ACH; difficult to conclude that secondary TB skin conversion cases arose from suggested sources and exclude other environmental/ community sources
4	Coronado et al. (1993)	Hospital (MDRTB)	Epidemiologic study with limited airflow study	Airflow	HVAC systems were evaluated with smoke tube observation of airflow directions	Transmission of MDRTB among HIV-infected patients in an urban hospital may be associated with lack of negative pressure in isolation rooms	Average/average	Non-conclusive	No patient room had adequate ventilation; study is strong from the microbiology side, with molecular typing to link the secondary cases; however, ventilation component is limited
5	Cotterill et al. (1996)	ITU (MRSA)	Epidemiologic study with some airflow measurement	Airflow	Smoke testing for detection of airflow currents	Exhaust air of an isolation room re-entered into an ITU through a partially open window; six patients infected with MRSA	Average/average	Non-conclusive	Phage-typing of isolates linked some cases together, but ventilation component was mainly descriptive
6	D'Stasio and Trump (1990)	Navy ship (TB)	Epidemiologic study with limited airflow studies	Airflow	Ventilation requirement and airflow direction only reported descriptively	Closed ventilation system in ship contributed to a TB outbreak, with 216 new reactors to tuberculin skin test among 881 previous tuberculin-negative sailors	Average/average	Non-conclusive	Little attempt to link secondary cases both in terms of microbiology and airflow; no attempt to demonstrate airflow direction; in such close-living conditions, it is difficult to exclude direct contact/fomite transmission routes
7	Dooley et al. (1992)	Hospital (TB)	Epidemiologic studies with very limited ventilation studies	Airflow	Direction of airflow tested using paper indicator strips	Patient-to-patient transmission of TB in HIV units and to HCWs in a large public hospital may be associated with non-functional exhaust fans in isolation rooms	Good/good	Non-conclusive	Ventilation is descriptive; with so many potential sources of TB, it was very difficult to conclude that ventilation and airflow had a definite role
8	Drinka et al. (1996, 2002, 2004)	Nursing home (influenza)	Epidemiologic study and limited investigation on ventilation type	Airflow	Not mentioned, but reported the types of ventilation in each building; no information about ventilation rate	One building with 100% outdoor air intake and no recirculation of exhaust air reported much lower attack rate of influenza than three other buildings with 30–70% of recirculated air	Unsatisfactory/unsatisfactory	Non-conclusive	Drinka et al. (2002, 2004) found that results in five subsequent seasons did not support the conclusion in Drinka et al. (1996); no attempt to link building ventilation to the cases, but with more emphasis on "architectural design"

9	Dutt et al. (1995)	Church (TB)	Epidemiologic study and limited investigation on ventilation type	Apart from reporting locations of vents, etc. in six lines, no other information on ventilation and airflow was given	Inadequate ventilation was suspected to be associated with a small but virulent TB outbreak	Average/average	Non-conclusive	Secondary cases were connected by positive tuberculin skin reactions, but ventilation study is only descriptive; slightly high infection risk in the front right section of the church; would be useful to measure ventilation rate and airflow pattern in the church
10	Edlin et al. (1992)	Hospital ward (MDRTB)	Epidemiologic study and limited investigation on airflows and ventilation	Smoke tube testing at doorway for airflow direction, with ventilation rate measurement, without giving the method	Fifteen of 16 patient rooms had outward flows in a hospital, with MDRTB infection among patients with AIDS	Average/average	Partly conclusive	Good demonstration of linkage using restriction fragment length polymorphism from the microbiology side, but ventilation component is limited; in three rooms, bi-directional flows were observed but without further study of the reasons
11	Ehrenkranz and Kicklighter (1972)	Hospital ward (TB)	Epidemiologic study and limited investigation on ventilation type	Ventilation evaluated by a mechanical engineer using a smoke stick visualizing airflow pattern	An area in a general hospital ward with an unbalanced ventilation system was responsible for at least 10 infected employees by an index TB patient, while less infection occurred in another area with better ventilation	Average/average	Partly conclusive	Ventilation study is limited to description of the system and use of smoke sticks; microbiology was limited to tuberculin skin conversions
12	Everett and Kipp (1991)	Hospital (any infection)	Epidemiologic study and ventilation rate studies	Use of air velocimeter for measuring air change rate in each operating room in six years, 1977, 1982, 1985–88	Infections increased when a community hospital ventilation system deteriorated and waited for repair, and returned to baseline rates once ventilation system was upgraded	Unsatisfactory/unsatisfactory	Non-conclusive	Some description of ventilation system, and seasonal changes in the number of diagnosed surgical-related patient infections; connection between ventilation and patient infection was not demonstrated conclusively, especially when no specific, but any and all organisms were included in the analysis
13	Fennelly et al. (2004a)	Postal facilities (anthrax)	Mathematical modeling using Wells-Riley equation	Methods for measuring ventilation rates not mentioned	Infectious quota was calculated in the two postal facilities in the 2001 US bioterrorism-related inhalation anthrax outbreak	Average/average	Non-conclusive	Facilities ventilated with 5.29 and 2.88 ACH with varying percentage of outdoor air; this is a model study and does not present any experimental evidence
14	Gustafson et al. (1982)	Hospital (chick enpox)	Epidemiologic and detailed airflow studies	Detailed airflow and dilution studies using SF <sub>6</sub> as a tracer gas, smoke puff study, with a detailed description of ventilation system	In an outbreak of varicella in a pediatric floor in a hospital, the spatial distribution of the infected agreed with measured SF <sub>6</sub> concentration distribution in a corridor on both sides of the index patient's room	Good/good	Conclusive	Index patient's room was in positive pressure; no attempt at molecular epidemiology of the YZV in secondary chickenpox cases, though there is a statement that seems to exclude acquisition of infection from other sources
15	Hoge et al. (1994)	Jail (pneumococcal disease)	Case-control, cohort, intervention studies and detailed ventilation studies	Detailed ventilation studies measuring both ventilation rate and CO <sub>2</sub> levels	In a jail, cell blocks with the worst combination of crowding and poor ventilation had the highest rates of disease in an epidemic of pneumococcal disease; as low as 5 ft <sup>3</sup> of ventilation rate per person was reported, with a median of 10 ft <sup>3</sup> with overcrowding in the jail	Good/good	Conclusive	Case-finding performed using standard diagnostic microbiological techniques, including serotyping the isolates; quantitative ventilation rate per person was presented
16	Houk et al. (1968)	Navy ship (TB)	Epidemiologic study and some investigation on ventilation	Only locations of supply and exhaust outlets were identified with speculated airflow pattern	Ventilation system in a closed navy ship of 308 crew members was associated with a large TB outbreak	Average/average	Non-conclusive	Both skin conversions and clinical cases of TB arising from an index case on this ship; no detailed study of airflow

Table 1 (Continued.)

Study no.	Reference	Setting (infectious agent)	Methods		Main results	Methodological quality/overall quality of the studies	Findings in relation to the evidentiary threshold	Remarks
			Epidemiologic	Airflow				
17	Hutton et al. (1990)	Hospital (TB)	Epidemiologic and detailed airflow studies	Measured both aerosol generation and dispersion, and ventilation rates and air currents by an anemometer and smoke tubes	Droplet nuclei generated in a positive pressure room with source patient of TB dispersed into corridor, causing nine secondary cases and 59 tuberculin skin test conversions	Good/good	Conclusive	Good demonstration of airflow in relation to source and secondary cases; secondary cases identified by tuberculin skin conversions and some clinical cases
18	Kantor et al. (1988)	Hospital (TB)	Epidemiologic investigation with limited ventilation analysis	Ventilation evaluated by hospital's engineering service	Nine of 56 hospital staff exposed to TB index patient in a hospital during hospitalization and autopsy, and high rate of infection was associated with inadequate air ventilation and exposure to uncontained infectious aerosol	Average/average	Non-conclusive	Ventilation report is just descriptive with no demonstration of airflow; secondary cases identified by tuberculin skin reactivity
19	Kenyon et al. (1996)	Aircraft (MDRTB)	Epidemiologic study and limited investigation of air distribution	Ventilation system reported by manufacturer of aircraft	Transmission of MDRTB in a commercial aircraft with a highly infectious passenger and a long flight was limited to close proximity of contacts to the index patient	Average/average	Non-conclusive	Ventilation report is only descriptive; secondary cases identified by tuberculin skin reactivity and declared that they had no other exposure; link between plane's ventilation system and secondary cases was assumed
20	Kumari et al. (1998)	Orthopedic ward (MRSA)	Epidemiologic study and limited investigation of ventilation system	Swabs collected at different points in ventilation system; collected design data such as airflow rates	Outbreak of MRSA in an orthopedic ward was related to intermittent ventilation system; outbreak terminated after system cleaning and restored continuous ventilation	Average/average	Partly conclusive	Ventilation system analysis was only descriptive; contrary to authors' claim, the suggestion of negative pressure created by daily shutdown was not supported by any data
21	Le et al. (2004)	Two hospitals (SARS)	Questionnaire study	No investigation of ventilation conditions in either hospitals; ventilation factor unfortunately mixed with other factors	No secondary infection occurred in hospital B with large rooms and open windows in the presence of 33 confirmed SARS cases, who were infected in hospital A with smaller rooms and individual air-conditioning units	Average/average	Non-conclusive	Effect of ventilation is unknown as no data were available; authors suggest that architectural differences between the hospitals may have played a part in the difference in nosocomial transmission
22	Leclair et al. (1980)	Pediatric ward (chickenpox)	Epidemiologic study and detailed flow pattern study	Airflow rates measured by a velometer, while flow pattern measured by SF <sub>6</sub> tracer gas, smoke puffs and aerosolized oil of wintergreen	Airflow between rooms in a pediatric ward caused chickenpox infection of 13 susceptible children with an index case in a positive pressure room	Good/good	Partly conclusive	Index patient's room had no air exhaust, while room G with an inoperative HVAC wall unit had the highest attack rate (9/10); airflow study is non-quantitative; secondary cases linked to an index case by history and they denied contact with any chickenpox sources outside hospital
23	Li et al. (2005a), Wong et al. (2004), Yu et al. (2005)	Hospital ward (SARS)	Epidemiologic study and detailed flow pattern study	Retrospective on-site measurement of ventilation and CFD predictions	Both measured and predicted aerosol distribution agreed well with spatial infection pattern of SARS cases in ward 8A with 138 infected cases	Good/good	Conclusive	Index patient's cubicle had an inoperative exhaust outlet; index case was connected to secondary cases by detailed temporal-spatial information, though no molecular epidemiology connection is reported
24	Li et al. (2005b)	High-rise apartments (SARS)	Epidemiologic study and detailed natural ventilation simulation study	CFD modeling of wind pressure coefficients and use of multi-zone modeling to predict ventilation rate and virus spread between flats	Distribution of SARS infection risk matched with predicted virus concentrations in flats in the 33-storey high residential block E, with the majority of infections in flats 7 and 8	Average/good	Partly conclusive	No field measurement was made, and predicted results using multi-zone modeling need to be confirmed by experiments; results showed importance of natural ventilation in high-rise residential buildings

25	Lidwell et al. (1975)	Hospital (S. aureus)	Population-based study and measurement of numbers of <i>Staphylococcus aureus</i> , and analysis of nasal acquisition of patients ( $n = 4296$ )	No measurement and details on ventilation given	Reduction of numbers of airborne <i>S. aureus</i> in a new hospital with modern ventilation system did not cause a reduction in rates of nasal acquisition of the infection	Good/good	Non-conclusive	Authors used swabs from personnel and settle plates to ascertain presence of <i>S. aureus</i> ; some conclusion about how transmission exceeds that expected from just an airborne route, but did not demonstrate airflow in the environment
26	Menzies et al. (2000)	Hospitals (TB)	Cross-sectional observational survey and population-based study	Air change rates in 17 hospitals by a CO <sub>2</sub> method	Tuberculin conversion among HCWs was strongly associated with inadequate ventilation in general patient rooms, and with type and duration of work, but not with ventilation of isolation rooms	Good/good	Conclusive	One of the rare detailed population-based study on the role of ventilation in hospitals; higher TB infection risk for HCWs working in non-isolation rooms with <2 ACH; cases of TB infection identified using tuberculin skin reactions
27	Meselson et al. (1994)	City (anthrax)	Epidemiologic study and detailed wind flow simulation study	Atmospheric dispersion modeling as well as a brief discussion on the possible penetration of anthrax aerosols into buildings	Distribution of anthrax infection risk matched with predicted aerosol concentrations in narrow zone in a city with a possible escape of anthrax pathogen from a military facility	Good/good	Partly conclusive	No field airflow measurements made; anthrax was enzootic in sheep and cattle in that area for many years prior to this event, so it is also possible for human cases to have derived from animal cases or the environment
28	Moser et al. (1979)	Aircraft (influenza)	Questionnaire study; some secondary cases linked by influenza typing	No detailed study but ventilation system was inoperative at the time; ventilation conditions estimated from onboard warm feeling of passengers at 1.7°C outdoor air	72% of passengers infected with influenza due to poor ventilation in a jet airliner grounded with engine failure for 3 h; attack rate varied with amount of time spent aboard	Average/average	Conclusive	It is interesting to compare this outbreak with that reported by Kenyon et al. (1996) on MDRTB, in which highly infectious TB transmission was limited to proximity of index patient, when ventilation system was effective
29	Myatt et al. (2004)	Offices (rhinovirus)	Measurement of CO <sub>2</sub> levels and air borne rhinovirus in three office buildings	Ventilation rate was shown by CO <sub>2</sub> concentration	Significant positive association between frequency of virus detection in air filters and background adjusted CO <sub>2</sub> concentration of 100 ppm and above	Average/average	Partly conclusive	No exclusion of community-acquired cold illness had been carried into building; data were conclusive in showing workers acquired their cold illness within the office building from other people in the same building
30	Nardell et al. (1991)	Office (TB)	Mathematical modeling using Wells–Riley equation	Ventilation rates estimated from CO <sub>2</sub> concentrations to be 15 cfm	Infectious quota was calculated in an office TB outbreak; CO <sub>2</sub> concentration measurement indicated suboptimal ventilation, and the effects of increasing ventilation rate were predicted	Good/good	Non-conclusive	Study based on an index case producing 27 secondary cases, identified by tuberculin skin reactivity; this is a modeling study paper and does not provide experimental evidence
31	Olsen et al. (2003)	Aircraft (SARS)	Epidemiologic study and no investigation on air distribution	Airflows in aircraft were not investigated	Transmission of SARS in a commercial aircraft (flight 2) with a highly infectious passenger, caused 22 new infections, with close proximity to index patient having the highest risk, infected as far as seven rows in front of index patient	Average/average	Partly conclusive	Secondary cases identified using WHO SARS case criteria at the time, from questionnaires, by telephone contact or in person; ventilation was hardly described, though proximity of index and secondary cases make the study partly convincing
32	Remington et al. (1985)	Pediatrician office (measles)	Epidemiologic study and some ventilation studies with modeling using Wells–Riley equation	Used hot wire anemometer to measure airflow and ventilation, and ventilation rate estimated from indoor thermal conditions	Three children who arrived in a 100-m <sup>2</sup> pediatrician's office after the index child departed developed measles due to extended exposure to remaining airborne virus	Good/good	Partly conclusive	Some description of ventilation system with some airflow analysis; some description of secondary cases, but most of the paper is an airborne transmission model, so cannot be definitive



Table 1 (Continued.)

Study no.	Reference	Setting (infectious agent)	Methods		Main results	Methodological quality/overall quality of the studies	Findings in relation to the evidentiary threshold	Remarks
			Epidemiologic	Airflow				
33	Riley et al. (1962)	Test chamber (TB)	Experimental study using guinea pigs, case-control	Both air exposure chambers and air ducts to the exposure chamber were specially designed	Air from a tuberculosis ward delivered to an exposure chamber caused 63 infections, while no infection in a control chamber with UV-irradiated air delivery	Good/good	Conclusive	Study also proved infectivity of exhaust air from a tuberculosis ward
34	Riley (1979), Riley et al. (1978)	School (measles)	Epidemiologic study and ventilation studies with modeling using Wells-Riley equation	Details of ventilation systems were given, but method of ventilation study was not clear	Central ventilation system in classrooms measles epidemic in a modern suburban elementary school	Good/good	Partly conclusive	Study included details of ventilation systems, as well as activities and whereabouts of the schoolchildren, which allowed the calculation of exposure; subsequent cases were described in relation to index and other cases in great detail; infection transmission model was developed based on this very accurate data
35	Schulman and Kibourne (1962)	Cage (influenza)	Experimental study using mice with three different ventilation rates	No details of cage ventilation design or ventilation measurement given	Chance of acquiring airborne influenza infection by mice was found to be inversely related to ventilation rate	Good/good	Conclusive	High relative humidity was also shown to be effective in decreasing infection rate
36	Shigematsu and Minowa (1985)	Office (TB)	Epidemiologic study and ventilation studies	Schematic diagram of air-conditioning system and measured hourly CO <sub>2</sub> and floating dust levels shown	Frequent shutdown of mechanical ventilation system attributed to a TB outbreak on the 4th floor of an office building	Unsatisfactory/unsatisfactory	Non-conclusive	Lack of TB infection on other floors in the same office was not well studied; no demonstration of how data presented links index (diagnosed in June 1979) and secondary (diagnosed in March 1982) cases, which may have been independently acquired
37	Ussery et al. (1995)	Hospital (MDRTB)	Epidemiologic study and environmental investigations	Ventilation rates measured and airflows visualized by smoke (including a smoke tube)	Leaked air from the autopsy room during autopsies on persons with MDRTB infected some employees in a medical examiner's office	Unsatisfactory /unsatisfactory	Non-conclusive	Secondary cases of TB were diagnosed by tuberculin skin reactivity; no convincing demonstration that secondary cases were linked to ventilation system
38	Wehrle et al. (1970)	Hospital (smallpox)	Epidemiologic study and detailed flow visualization study	Smoke generator used to visualize airflow pattern from index patient's room at the ground floor	Seventeen cases of smallpox located on three floors in a hospital caused by air spread due to buoyancy through corridors and stairwells, as well as through open windows from index patient's room at the ground floor	Good/good	Conclusive	Detailed temporal-spatial descriptions of index and secondary cases, as well as airflow inside and outside hospital building around index case using smoke; good correlations between attack rates and smoke movements
39	Yu et al. (2004)	High-rise housing estate (SARS)	Epidemiologic study and detailed wind flow simulation study	CFD modeling of wind flows as well as multi-zone modeling. No experiments in the Amoy Gardens were carried out	Distribution of SARS infection risk matched with predicted virus concentrations in four of 19 blocks in the Amoy Gardens high-rise housing estate SARS outbreak, with majority of infections in block E caused by plume and wind flows	Good/good	Partly conclusive	No field measurement made; modeling airflow was essentially descriptive, making the long-distance airborne transmission of SARS hypothesis plausible, and only partly conclusive
40	Zitter et al. (2002)	Aircraft (common cold)	Case-control study (n = 1100)	No ventilation measurement in two types of airplanes carried out; efficiency of HEPA filters used was also not mentioned	No differences in self-reported common cold after traveling in airplanes with 100% and only 50% of fresh outdoor air	Unsatisfactory /unsatisfactory	Non-conclusive	Conclusions do not exclude other sources of common colds (the viruses of which can have various incubation periods of 1–5 days), thus some passengers could have acquired the common cold after getting off the plane (e.g. waiting in line at customs) rather than from the plane, in either group

ACH, air changes per hour; CFD, computational fluid dynamics; HVAC, heating, ventilating and air-conditioning system; MDRTB, multidrug-resistant tuberculosis; MRSA, methicillin-resistant *Staphylococcus aureus*; HEPA, high-efficiency particulate air; HCW, healthcare worker; SARS, severe acute respiratory syndrome; SF<sub>6</sub>, sulphur hexafluoride; VZV, Varicella zoster virus.

animals in the same cage, but separated using double mesh wire screen with three-quarter inch separation. The chance of the mice acquiring airborne influenza infection was found to be inversely related to ventilation rate. High relative humidity was also shown to be effective in decreasing the infection rate.

The work of Menzies et al. (2000), Schulman and Kilbourne (1962) and Hoge et al. (1994) clearly provided direct and strong evidence for the Wells–Riley equation (Riley et al., 1978). ‘The rate of increase of new case of airborne contagion in a group breathing the same atmospheric expresses this contagious potential – inversely proportional to the sanitary ventilation per susceptible occupant’ (Wells, 1955). This also means that the subsequent analysis using the Wells–Riley equation (e.g. Fennelly and Nardell, 1998; Nardell et al., 1991) is justified. Menzies et al. (2000) presented one of the rare detailed population-based studies of the role of ventilation in hospitals. It showed a higher TB infection risk for healthcare workers working in non-isolation rooms with ventilation rates of less than two air changes per hour. Hoge et al. (1994) found that in a jail, cell blocks with the worst combination of crowding and poor ventilation had the highest rates of disease in an epidemic of pneumococcal disease. The attack rate in a cell block with a ventilation rate of 4.2 ft<sup>3</sup>/min per person was 7.3 cases per 1000 inmates, while only 3.1 and 4.4 cases/1000 were reported in cell blocks with ventilation rates of 8.0 and 7.1 ft<sup>3</sup>/min per person, respectively.

Moser et al. (1979) investigated an opportunistic outbreak of influenza due to a lack of outdoor air coming into the enclosed space of an aircraft. The ventilation conditions were estimated from the passengers reported feelings of being ‘comfortable’ or ‘warm’, despite the outside air being only 1.7°C, and absence of air-conditioning and mechanical ventilation. This was interpreted by the authors as evidence of poor air exchange between the plane compartment and the outdoor air. It is known through basic ventilation theory that some outdoor air might have been introduced into the cabin by infiltration through various possible aircraft leakages (Etheridge and Sandberg, 1996).

Among the 12 partly conclusive studies, five showed an effect of ventilation flow rate, including Calder et al. (1991), Ehrenkranz and Kicklighter (1972), Li et al. (2005b), Myatt et al. (2004), and Riley et al. (1978). For example, Myatt et al. (2004) carried out an environmental study that attempted to link symptomatic ‘cold’ illness in an office building, the detection of rhinovirus RNA fragments and building ventilation. There was a significant positive association between the frequency of virus detection in air filters and the background-adjusted carbon dioxide concentration of 1000 ppm and above. There was at least one symptomatic ‘cold’ case matched by molecular methods to an

environmental rhinovirus RNA fragment. However, there was no exclusion of community-acquired cold illness that had been carried into the building. It was also not known conclusively whether workers acquired their cold illness within the office building from other people in the same building. Supplementary on-line material of Myatt et al. (2004) used the Wells–Riley equation to model the potential for acquiring infection within the building environment.

#### Role of airflow patterns

Ventilation rate is a measure of how much outdoor air is supplied into a building, while air in a building moves because of various natural and fan forces. Air also moves from one room to another because of pressure differences through leakages or doorways. Such air movement in buildings is generally turbulent (Etheridge and Sandberg, 1996), which is also known to be effective in the transport of airborne pathogens. Among the 10 studies considered to be conclusive, five showed an association between airflow patterns and the spread of diseases, i.e. Bloch et al. (1985), Gustafson et al. (1982), Hutton et al. (1990), Wehrle et al. (1970), and the study of a SARS outbreak by Li et al. (2005a), Wong et al. (2004), and Yu et al. (2005).

In all five studies, a few secondary cases or even a large number of cases at a considerable distance away from the index patient were shown to be infected via an airborne transmission route. It is also interesting that all the outbreaks investigated in the five studies occurred in hospitals or pediatric offices, suggesting the importance of air environments in healthcare settings. As the first ‘conclusive’ study, Wehrle et al. (1970) used smoke tests in a hospital to show the airflow pattern and dispersion of virus-laden aerosols from the index patient’s room in a three-storey hospital. The smallpox outbreak occurred in mid-January in Meschede in the former Federal Republic of Germany. The heat emitted from the radiators used for space heating introduced the upward flows through the stairwell, as well as above the semi-open windows (for ventilation). Such air currents carried virus-laden aerosols into other rooms in the upper floors and subsequently caused infection and disease (Langmuir, 1980).

In addition to smoke testing, tracer gas techniques or direct aerosol dispersion measurements were used in the three studies in the 1980s and 1990s (Bloch et al., 1985; Gustafson et al., 1982; Hutton et al., 1990). The study of Li et al. (2005a), Wong et al. (2004), and Yu et al. (2005) was based on the same nosocomial transmission of SARS events at a hospital in 2003, examining inpatients, medical students and airflows, respectively. Both the measured and predicted aerosol distribution agreed well with the spatial infection pattern of SARS cases in ward 8A with 138 infected

cases. They also carried out retrospective on-site measurements of ventilation and used CFD simulations to predict the droplet nuclei dispersion in the ward at the time of infection. It should be noted that no molecular epidemiology connection was reported in these papers. The SARS cases among inpatients (Yu et al., 2005) were not considered conclusive evidence of airborne transmission, but the SARS cases among the medical students (Wong et al., 2004) was considered to be conclusive by this panel.

In all five studies, the considerable distance traveled by the virus- or bacteria-laden aerosols seemed to be related to building design. In the Meschede smallpox outbreak (Wehrle et al., 1970), the heating radiator in the index patient's room introduced the upward plume flow through its semi-open window. For the TB outbreak from a draining abscess (Hutton et al., 1990), the measles outbreak in a pediatric office (Bloch et al., 1985) and the nosocomial varicella outbreak (Gustafson et al., 1982), the index patients' rooms were all in positive pressure, which caused the virus to spread into either corridors or other rooms. It is also noted that in the nosocomial SARS outbreak (Li et al., 2005a), the index patient's cubicle had an inoperative return air outlet, which enhanced the spread of aerosols into three other cubicles in the same hospital ward.

Eight of the partly conclusive studies also revealed the probable impact of airflow direction on disease transmission, i.e. Edlin et al. (1992), Kumari et al. (1998), Leclair et al. (1980), Li et al. (2005b), Meselson et al. (1994), Olsen et al. (2003), Remington et al. (1985), and Yu et al. (2004). Li et al. (2005b) found that the spatial distribution of SARS infection risk matched the predicted virus concentrations in flats in the 33-storey high residential block E of the Amoy Gardens outbreak, and it was affected by the wind direction. Yu et al. (2004) used both CFD and multi-zone airflow modeling to show the SARS transmission between flats and buildings in the Amoy Gardens housing estate. However, no experimental studies of airflows were carried out. The panel considers that the modeling of the airflow was essentially descriptive, making the long-distance airborne transmission of SARS hypothesis plausible, and only partly conclusive.

## Discussion

### Limitations of this study

For specialties, so different in terms of background training (epidemiology, chemistry and biology for medicine; and mathematics and physics for engineering), it is likely that the final decisions on what constituted a conclusive study represented a compromise between the reviewers and the panel as a whole. In addition, the age of the papers and the technology then

available had to be taken into consideration. The standards adopted for demonstrating the linkage between index and secondary cases during an outbreak of an airborne pathogen in the 1960s and 1970s, were quite different from the papers from the 1990s and 2000s. Hence, the level of 'conclusivity', as agreed by the panel, depended to a certain extent on the panel members' knowledge of how 'state-of-the-art' methodology used was, at the time of the study. With some papers, specialists within the same field of medicine or engineering would expect to have some difficulty in agreeing between themselves whether a study was 'conclusive' or 'partly conclusive', and 'partly conclusive' or 'non-conclusive'. In such situations, the chairman of the panel would have made the final decision, although such situations did not occur in this study.

### Specifying and/or quantifying minimum ventilation requirements in hospital and non-hospital environments

The 10 studies considered to be conclusive demonstrated the roles of building ventilation and airflows in relation to the spread or control of airborne infectious diseases. However, there was insufficient information/data to specify and/or quantify the minimum ventilation requirements in hospital and non-hospital environments in relation to the spread of airborne infection, apart from the work of Menzies et al. (2000). It is not surprising that the current design requirements for isolation rooms, operating theaters and general hospital areas are not based on solid evidence (Center for Disease Control and Prevention: CDC, 1994). Further studies are necessary to determine the ventilation requirements in non-hospital environments such as offices, homes and schools. It may be beneficial for schools, residential homes for the elderly or institutions for the mentally ill, as well as prisons, to have a higher ventilation rate during influenza peak seasons. One of the difficulties in developing ventilation requirements is in the quantification of the infectious sources and the exposure of the population.

For new diseases such as SARS, the available evidence regarding risk of transmission and transmission routes has not been adequately studied, or the studies are poorly designed and give inconsistent results. Well-designed, well-conducted, prospective cohort or case-control observational studies should be carried out. Interventional studies with consenting, healthy volunteers using relatively harmless infectious pathogens may provide the best evidence. Further work is also required to develop practical, robust and valid methods for measuring indoor bioaerosols, due to their low concentration and mobility.

In addition to the approach used by Menzies et al. (2000), another possible approach for determining ventilation requirements is to first determine the

infectious dose and source strength. The infectious dose of a pathogen is the number of organisms required to cause infection in a susceptible host. For most pathogens, the infectious dose varies between individual pathogens and their hosts. For hardy bacteria such as mycobacterium TB, only a single organism is needed to cause disease (Haas, 2000). Some other organisms can produce disease with as few as 1–100 organisms (Franz et al., 1997), e.g. *Coxiella burnetii* (Q fever) 1–10, smallpox 10–100, and *Ebola* and *Marburg* viruses (viral hemorrhagic fevers) 1–10 organisms. Obviously, if the number of organisms released from the infected source is known, knowledge of the infectious dose of airborne pathogens may allow us to estimate the required ventilation rate and exposure time to reduce the concentration of a pathogen to below its infectious dose.

The concept of quantal infection suggested by Wells (1955) is useful, where a quantum of infection is the number of infectious airborne particles (dose) required to produce infection in a susceptible host. For an outbreak, the quanta of infection produced by the index patient may be calculated, as was demonstrated for a measles outbreak by Riley et al. (1978).

In general indoor environments, a total bacteria count is generally specified in indoor air quality standards. For example, some operating theaters guidelines recommend that the bio-load in an empty theater should not exceed 35 bacteria-carrying particles (e.g. skin scales) per cubic meter (bcp/m<sup>3</sup>) of air (Holton and Ridgway, 1993; NHS Estates, 1994). Similarly, during an operation, the bio-load should not exceed 180 colony-forming units per cubic meter (cfu/m<sup>3</sup>) (Holton and Ridgway, 1993).

Various guidelines for ventilation in healthcare facilities and isolation rooms have been suggested by American Institute of Architects (1996), ASHRAE (2003), CDC (1994), Health Canada (1996), and Department of Human Services (1999), and on ultraviolet germicidal irradiation (UVGI) (First et al., 1999). A related topic is air filtration and the use of UVGI. The effect of air filtration was studied by Rutala et al. (1995), Sheretz et al. (1987), and Adal et al. (1994). Nardell (1993) reviewed the pros and cons of ventilation (fans), filtration (filters) and UVGI (rays). Fennelly and Nardell (1998) examined the relative efficacy of the use of respirators and room ventilation in preventing occupational TB.

On ventilation rate, the topic of overcrowding should be mentioned, although it may be arguable to justify that overcrowding is equivalent to ventilation and airflows. For example, the studies by Elender et al. (1998), Leung et al. (2004) and Reinhard et al. (1997) on the socioeconomic factors of TB, suggested that the risk of transmission of TB is not associated with overcrowding at the district level, but associated with overcrowding at the housing units level. This suggests

the importance of indoor air environments, as the transmission of TB is known to be airborne. After examining the relative trends in mortality from respiratory and airborne infectious diseases in the 19th century and beginning of the 20th, Mercer (1986) argued that reduced mortality rates were the result of improved building ventilation and reduced crowding, as well as vaccination for some diseases such as smallpox, but not changes in general living conditions, standards of living or nutrition. Very often overcrowding is identified as a factor that may be related to ventilation of buildings. However, without details of airflow rates, it is difficult to rigorously demonstrate a direct relationship between overcrowding and the airborne transmission of infection. Moreover, overcrowding may increase the likelihood of disease transmission via direct contact.

Design for airflow patterns and pressure control between multiple rooms in buildings

Existing reviews on ventilation and health have focused almost exclusively on ventilation flow rates. Airflow patterns in buildings have been studied extensively by engineers over the last 30 years, and there is mounting evidence of the transportation of other pollutants in buildings by airflows. It is known that the airflow direction should be controlled between rooms, i.e. from corridors to a toilet. Indeed, the very basic principle in ventilation control of pollutants in a building should be airflows from clean zones to dirty zones. With today's air pressure control technologies, such airflow control design has become possible in most buildings including hospitals, but at a cost.

Disease outbreaks investigated in the five conclusive studies demonstrating the association between air movement and the spread of diseases, all occurred in either hospitals or clinics (Bloch et al., 1985; Gustafson et al., 1982; Hutton et al., 1990; Wehrle et al., 1970; and the study by Li et al., 2005a, Wong et al., 2004, Yu et al., 2005). In all outbreaks, the spread of diseases occurred due to the dispersion of pathogen-laden aerosols from where the index patient stayed to other rooms or other parts of the same room. The SARS outbreak in ward 8A is alarming, as the spread of aerosols from the index patient's cubicle into other cubicles was partly due to the inoperative exhaust in the index patient's cubicle (Wong et al., 2004). This suggested the significance of proper and regular maintenance of ventilation systems in hospital wards. The airflow patterns that contributed to the outbreaks of SARS in a ward, smallpox in a hospital, TB in a hospital, measles in a pediatric suite, and chickenpox on a pediatric floor are striking. As a whole, these studies revealed that an efficient airflow pattern should be designed for a building with potential infectious sources.

Although the theory of maintaining negative pressure for isolation rooms is simple, it can be a difficult task to achieve in hospitals wards (Rice et al., 2001). As much as 45% of negative pressure rooms have positive airflow to corridors, as found in field investigations, e.g. Fraser et al. (1993).

Need for a multidisciplinary study to identify an association between ventilation and airborne transmission of diseases

The following reasons might have contributed to the relatively rare conclusive scientific evidence of the roles of ventilation and airflow in the transmission of airborne diseases.

First, in nearly all situations/outbreaks, there are a large number of factors that can contribute to the transmission of infection, and it can be very difficult to identify that ventilation is a main factor. Most existing studies deal with multiple co-existing factors, which makes it difficult to completely rule out the possibility of transmission by other routes.

Secondly, the most inherent limitation in almost all existing investigations is due to the rapid disappearance of airborne evidence of infection, once the infectious period is over. It becomes very difficult to then, *retrospectively*, reproduce the same ventilation and airflow conditions that existed at the time of the outbreak. Most of the time, outbreaks are only noticed when a significant number of people have been infected, so by this inherent nature, it is difficult to estimate, accurately, the exact time of onset of infection in the index case, as well as in any secondary cases. The presence of airborne infectious pathogens can 'disappear' rapidly after the source has been removed. One way to overcome this difficulty in outbreak investigation is to have a strong clinical suspicion, which will develop during a prolonged outbreak, then to arrange contemporaneous air-sampling and environmental measurements in this location during a patient's illness. Such studies were undertaken during the SARS outbreaks of 2003 (Booth et al., 2005; Xiao et al., 2004). It is therefore important to note that most of the 10 studies chosen as conclusively demonstrating a *physical* link between airflow/ventilation and aerosol transmission of infection did not include contemporaneous air-sampling or nucleic acid sequencing of infected secondary cases to confirm a *molecular* link (Jalal et al., 2005; Tang et al., 2005). This is a modern requirement for characterizing transmission events that cannot be applied to these older studies where the technology either did not exist or was unavailable to the investigating teams. Therefore, we could only assess these studies on the best available evidence at the time that they were conducted, and not by the more rigorous modern standards.

Thirdly, despite the mounting evidence that some diseases are airborne, the methodological limitations

imply that the evidence for ventilation impact is often too difficult to be quantified. It may even be argued that the existing literature is subject to bias. The available advanced measurement methods for ventilation and air distribution at the time of investigation were not used by the investigators in many of the studies reviewed here. These readily available techniques (Etheridge and Sandberg, 1996) include various flow visualization methods for airflows in buildings, passive and active tracer gas methods for ventilation flow rates, CFD simulations for predicting airflow patterns, multi-zone airflow modeling for global airflow patterns, and airflow rates in multiple buildings. Most of these ventilation and airflow methods are often not available to most epidemiologists and microbiologists. The fact that many existing epidemiological studies, including those in this review, do not include adequate airflow studies reflects the lack of participation of engineers in outbreak investigations, or the lack of access to available engineering measurement methods by the investigation team.

Finally, in collocating evidence of an association between ventilation and the airborne transmission of diseases, other factors need consideration. These include the generation of infectious pathogen-containing aerosols, the survivability of infectious pathogens in air (Arundel et al., 1986; Cox, 1987; Ijaz et al., 1985), and the infectious dose. On the issue of the detection of airborne viruses/bacteria, new molecule microbiological methods have found their use. For example, detection of mycobacterium TB in different indoor environments was carried out by Fennelly et al. (2004b), Mastorides et al. (1997, 1999), Vadrot et al. (2004), Wan et al. (2004), and Schafer et al. (2003), using polymerase chain reaction methods and micro-pore membrane air sampling, etc. Similar methods were also used for the detection of airborne rhinovirus by Myatt et al. (2003, 2004). These new microbiological methods are often not available to most engineers.

Our review strongly suggests the need for a multidisciplinary approach to investigate an outbreak of a potentially airborne disease, and to carry out a cross-sectional survey and population-based study, such as those used by Menzies et al. (2000). In fact, such a multi-disciplinary approach can be activated not just in large outbreak situations, but also on smaller scale, nosocomial transmission events, where such events may have larger implications for the hospital ward or unit concerned (Tang et al., 2005). There is a need to develop a multidisciplinary research culture, not only for investigating a particular outbreak, but also for general research challenges related to the control of disease spread in buildings. A multidisciplinary team of infectious disease and engineering specialists needs to be rapidly assembled as soon as an airborne infectious disease outbreak is identified, in order to accurately and comprehensively measure and document all rele-

vant parameters (relating to both the people and the environment) at the earliest possible time. This will allow a detailed causal analysis to be performed, once the outbreak is over, with contemporaneous data collected during the outbreak. Obviously, the measurement of such parameters must take place in a manner that does not interfere with the healthcare-related aspects of the outbreak.

For environmental investigations into the roles played by airflow and ventilation, the determination of the infection time and location is crucial. To determine if the index and secondary cases are linked in an outbreak situation, modern techniques must now be used. Typing methods and nucleic acid sequencing techniques allow the infectious pathogens isolated from different individuals to be minutely compared, to examine whether such cases of disease have arisen through direct transmission of the same pathogen. Hence, clinical samples taken during the acute phase of infection are necessary. For patients already in hospitals, this is possible and likely. However, for healthcare and office workers, such timely sampling may only be performed under specific study conditions.

## Conclusions

The following consensus was reached by the assessment panel members:

- 1 Within the contemporary limitations of the conclusive studies chosen here, there is strong and sufficient evidence to demonstrate the association between ventilation and the control of airflow directions in buildings and the transmission and spread of infectious diseases such as measles, TB, chickenpox, anthrax, influenza, smallpox, and SARS. This evi-

dence supports the use of negatively pressurized isolation rooms for patients with these diseases in hospitals, in addition to the use of other engineering control methods.

- 2 There is insufficient evidence/data to support the specification and quantification of the minimum ventilation requirements in hospitals and isolation rooms in relation to the spread of airborne infectious diseases. The knowledge gap is obvious.
- 3 There is also no evidence/data to support the specification and quantification of the minimum ventilation requirements in schools, offices and other non-hospital environments in relation to the spread of airborne infectious diseases. The knowledge gap is obvious.
- 4 There is a strong need for a multidisciplinary study in investigating outbreaks and the impacts of the air environment on the spread of potentially airborne infectious diseases. Such an approach would allow the combined use of the available molecular biology test methods and the new computer modeling and experimental methods for investigation building ventilation.

## Acknowledgements

The work described in this paper was jointly supported by a grant from the Research Grants Council of the Hong Kong SAR Government (Project No. HKU 7115/04E), a Hospital Authority-commissioned project under the Research Fund for the Control of Infectious Diseases (RFCID) by the Health, Welfare and Food Bureau (Project No. HA-NS-002), Hong Kong SAR Government, and a University of Hong Kong Outstanding Young Researcher Award.

## References

- Adal, K.A., Anglim, A.M., Palumbo, C.L., Titus, M.G., Coyner, B.J. and Farr, B.M. (1994) The use of high-efficiency particulate air-filter respiration to protect hospital workers from tuberculosis: a cost-effectiveness analysis, *N. Engl. J. Med.*, **331**, 169–173.
- Aitken, C. and Jeffries, D.J. (2001) Nosocomial spread of viral disease, *Clin. Microbiol. Rev.*, **14**, 528–546.
- American Institute of Architects (1996) *Guidelines for Design and Construction of Hospital and Health Care Facilities, 1996–97*, Washington, DC, American Institute of Architects Press.
- Arundel, A.V., Sterling, E.M., Biggin, J.H. and Sterling, T.D. (1986) Indirect health effects of relative humidity in indoor environments, *Environ. Health. Perspect.*, **65**, 351–361.
- ASHRAE (2003) *Handbook – HVAC Applications* (SI Edn), Chapter 7 – Health Care Facilities, Atlanta, GA, American Society of Heating, Refrigerating and Air-Conditioning Engineers, Inc.
- ASHRAE (2004) *Ventilation for Acceptable Indoor Air Quality (ANSI Approved)*, Standard 62.1–2004, Atlanta, GA: American Society of Heating, Refrigerating and Air-Conditioning Engineers, Inc.
- Bates, J.H. and Nardell, E. (1995) ACCP consensus statement: institutional control measures for tuberculosis in the era of multiple drug resistance, *Chest*, **108**, 1690–1710.
- Beggs, C.B. (2003) The airborne transmission of infection in hospital buildings: fact or fiction, *Indoor Built Environ.*, **12**, 9–18.
- Berglund, B., Brunekreef, B., Knoppel, H., Lindvall, T., Maroni, M., Molhave, L. and Skov, P. (1992) Effects of indoor air pollution on human health, *Indoor Air*, **2**, 2–25.
- Blcoch, A.B., Orenstein, W.A., Ewing, W.M., Spain, W.H., Mallison, G.F., Herrmann, K.L. and Hinman, A.R. (1985) Measles outbreak in a pediatric practice: airborne transmission in an office setting, *Pediatrics*, **75**, 676–683.
- Booth, T.F., Kournikakis, B., Bastein, N., Ho, J., Kobasa, D., Stadnyk, L., Li, Y., Spence, M., Paton, S., Henry, B., Mederski, B., White, D., Low, D.E., McGeer, A., Simor, A., Vearncombe, M., Downey, J., Jamieson, F.B., Tang, P. and Plummer, F. (2005) Detection of airborne severe acute respiratory syndrome (SARS) coronavirus and environmental contamination in SARS outbreak units, *J. Infect. Dis.*, **191**, 1472–1477.
- Breathnach, A.S., de Ruiter, A., Holdsworth, G.M., Bateman, N.T., O'Sullivan, D.G., Rees, P.J., Snashall, D., Millburn, H.J., Peters, B.S., Watson, J., Drobniowski, F.A. and French, G.L. (1998) An

- outbreak of multi-drug-resistant tuberculosis in a London teaching hospital, *J. Hosp. Infect.*, **39**, 111–117.
- Calder, R.A., Duclos, P., Wilder, M.H., Pryor, V.L. and Scheel, W.J. (1991) *Mycobacterium tuberculosis* transmission in a health clinic, *Bull. Int. Union Tuberc. Lung Dis.*, **66**, 103–106.
- CDC (1994) Guidelines for preventing transmission of *Mycobacterium tuberculosis* in health-care settings, *MMWR Morb. Mortal. Wkly. Rep.*, **43**, 1–132.
- Church, J. (1986) Spread of infection: airborne route, *Nursing (London)*, **3**, 129–130.
- Cole, E.C. and Cook, C.E. (1998) Characterization of infectious aerosols in health care facilities: an aid to effective engineering controls and preventive strategies, *Am. J. Infect. Control*, **26**, 453–464.
- Coronado, V.G., Beck-Sague, C.M., Hutton, M.D., Davis, B.J., Nicholas, P., Villareal, C., Woodley, C.L., Kilburn, J.O., Crawford, J.T. and Frieden, T.R. (1993) Transmission of multidrug-resistant *Mycobacterium tuberculosis* among persons with human immunodeficiency virus infection in an urban hospital: epidemiologic and restriction fragment length polymorphism analysis, *J. Infect. Dis.*, **168**, 1052–1055.
- Cotterill, S., Evans, R. and Fraise, A.P. (1996) An unusual source for an outbreak of methicillin-resistant *Staphylococcus aureus* on an intensive therapy unit, *J. Hosp. Infect.*, **32**, 207–216.
- Cox, C.S. (1987) *The Aerobiological Pathway of Microorganisms*, Chichester, UK, John Wiley & Sons.
- Daisey, J.M., Angell, W.J. and Apte, M.G. (2003) Indoor air quality, ventilation and health symptoms in schools: an analysis of existing information, *Indoor Air*, **13**, 53–64.
- Department of Human Services (1999) *Guidelines for the Classification and Design of Isolation Rooms in Health Care Facilities*, Victoria, Australia, Standing Committee on Infection Control, Department of Human Services.
- DiStasio, A.J. and Trump, D.H. (1990) The investigation of a tuberculosis outbreak in the closed environment of a U.S. Navy ship, 1987, *Mil. Med.*, **155**, 347–351.
- Dooley, S.W., Villarino, M.E., Lawrence, M., Salinas, L., Amil, S., Rullan, J.V., Jarvis, W.R., Bloch, A.B. and Cauthen, G.M. (1992) Nosocomial transmission of tuberculosis in a hospital unit for HIV-infected patients, *JAMA*, **267**, 2632–2634.
- Drinka, P.J., Krause, P., Schilling, M., Miller, B.A., Shult, P. and Gravenstein, S. (1996) Report of an outbreak: nursing home architecture and influenza-A attack rates, *J. Am. Geriatr. Soc.*, **44**, 910–913.
- Drinka, P.J., Krause, P., Nest, L., Gravenstein, S., Goodman, B. and Shult, P. (2002) Delays in the application of outbreak control prophylaxis for influenza A in a nursing home, *Infect. Control Hosp. Epidemiol.*, **23**, 600–603.
- Drinka, P.J., Krause, P., Nest, L. and Tyn dall, D. (2004) Report of an outbreak: nursing home architecture and influenza-A attack rates: update, *J. Am. Geriatr. Soc.*, **52**, 847–848.
- Duguid, J.P. (1945) The numbers and the sites of origin of the droplets expelled during expiratory activities, *Edinburgh Med. J.*, **52**, 385–401.
- Dutt, A.K., Mehta, J.B., Whitaker, B.J. and Westmoreland, H. (1995) Outbreak of tuberculosis in a church, *Chest*, **107**, 447–452.
- Edlin, B.R., Tokars, J.I., Grieco, M.H., Crawford, J.T., Williams, J., Sordillo, E.M., Ong, K.R., Kilburn, J.O., Dooley, S.W. and Castro, K.G. (1992) An outbreak of multidrug-resistant tuberculosis among hospitalized patients with the acquired immunodeficiency syndrome, *N. Engl. J. Med.*, **326**, 1514–1521.
- Ehrenkranz, N.J. and Kicklighter, J.L. (1972) Tuberculosis outbreak in a general hospital: evidence for airborne spread of infection, *Ann. Intern. Med.*, **77**, 377–382.
- Elender, F., Bentham, G. and Langford, I. (1998) Tuberculosis mortality in England and Wales during 1982–1992: its association with poverty, ethnicity, and AIDS, *Soc. Sci. Med.*, **46**, 673–681.
- Etheridge, D. and Sandberg, M. (1996) *Building Ventilation – Theory and Measurement*, Chichester, UK, John Wiley & Sons.
- Eubank, S., Guclu, H., Kumar, V.S., Marathe, M.V., Srinivasan, A., Toroczkai, Z. and Wang, N. (2004) Modelling disease outbreaks in realistic urban social networks, *Nature*, **429**, 180.
- Everett, W.D. and Kipp, H. (1991) Epidemiologic observations of operating room infections resulting from variations in ventilation and temperature, *Am. J. Infect. Control.*, **19**, 277–282.
- Fennelly, K.P. and Nardell, E.A. (1998) The relative efficacy of respirators and room ventilation in preventing occupational tuberculosis, *Infect. Control Hosp. Epidemiol.*, **19**, 754–759.
- Fennelly, K.P., Davidow, A.L., Miller, S.L., Connell, N. and Ellner, J.J. (2004a) Airborne infection with *Bacillus anthracis* – from mills to mail, *Emerg. Infect. Dis.*, **10**, 996–1002.
- Fennelly, K.P., Martyny, J.W., Fulton, K.E., Orme, I.M., Cave, D.M. and Heifets, L.B. (2004b) Cough-generated aerosols of *Mycobacterium tuberculosis*: a new method to study infectiousness, *Am. J. Respir. Crit. Care Med.*, **169**, 604–609.
- First, M.W., Nardell, E.A., Chaisson, W. and Riley, R. (1999) Guidelines for the application of upper-room ultraviolet irradiation for preventing transmission of airborne contagion: Part II – Design and operation guidance, *ASHRAE Trans.*, **105**, 1–10.
- Fisk, W.J. and Rosenfeld, A.H. (1997) Estimates of improved productivity and health from better indoor environments, *Indoor Air*, **7**, 158–172.
- Franz, D.R., Jahrling, P.B., Friedlander, A.M., McClain, D.J., Hoover, D.L., Bryne, W.R., Pavlin, J.A., Christopher, G.W. and Eitzen, E.M. Jr. (1997) Clinical recognition and management of patients exposed to biological warfare agents, *JAMA*, **278**, 399–411.
- Fraser, V.J., Johnson, K., Primack, J., Jones, M., Medoff, G. and Dunagan, W.C. (1993) Evaluation of rooms with negative pressure ventilation used for respiratory isolation in seven Midwestern hospitals, *Infect. Control Hosp. Epidemiol.*, **14**, 623–628.
- Goldmann, D.A. (2000) Transmission of viral respiratory infections in the home, *Pediatr. Infect. Dis. J.*, **19**, S97–S102.
- Guan, Y., Peiris, J.S., Zheng, B., Poon, L.L., Chan, K.H., Zeng, F.Y., Chan, C.W., Chan, M.N., Chen, J.D., Chow, K.Y., Hon, C.C., Hui, K.H., Li, J., Li, V.Y., Wang, Y., Leung, S.W., Yuen, K.Y. and Leung, F.C. (2004) Molecular epidemiology of the novel coronavirus that causes severe acute respiratory syndrome, *Lancet*, **363**, 99–104.
- Gustafson, T.L., Lavelly, G.B., Brawner, E.R. Jr., Hutcheson, R.H. Jr., Wright, P.F. and Schaffner, W. (1982) An outbreak of airborne nosocomial varicella, *Pediatrics*, **70**, 550–556.
- Haas, D.W. (2000) *Mycobacterium tuberculosis*. In: Mandell, G.L., Bennett, J.E. and Dolin, R. (eds) *Principles and Practice of Infectious Diseases*, 5th edn, Philadelphia, PA, Churchill Livingstone, 2576–2607.
- Health Canada (1996) Guidelines for preventing the transmission of tuberculosis in Canadian health care facilities and other institutional settings – IVE: engineering controls to minimize TB transmission, *Can. Commun. Dis. Rep.*, **22**(S1), i–iv, 1–50, i–iv, 1–55.
- Hinds, W.C. (1982) *Aerosol Technology*, New York, John Wiley & Sons.
- Hoge, C.W., Reichler, M.R., Dominguez, E.A., Bremer, J.C., Mastro, T.D., Hendricks, K.A., Musher, D.M., Elliott, J.A., Facklam, R.R. and Breiman, R.F. (1994) An epidemic of pneumococcal disease in an overcrowded, inadequately ventilated jail, *N. Engl. J. Med.*, **331**, 643–648.
- Holton, J. and Ridgway, G.L. (1993) Commissioning operating theatres, *J. Hosp. Infect.*, **23**, 153–160.
- Houk, V.N., Baker, J.H., Sorensen, K. and Kent, D.C. (1968) The epidemiology of tuberculosis infection in a closed environment, *Arch. Environ. Health*, **16**, 26–35.
- Hutton, M.D., Stead, W.W., Cauthen, G.M., Bloch, A.B. and Ewing, W.M. (1990)

- Nosocomial transmission of tuberculosis associated with a draining abscess, *J. Infect. Dis.*, **161**, 286–295.
- Ijaz, M.K., Brunner, A.H., Sattar, S.A., Nair, R.C. and Johnson-Lussenburg, C.M. (1985) Survival characteristics of airborne human coronavirus 229E, *J. Gen. Virol.*, **66**, 2743–2748.
- Jalal, H., Bibby, D.F., Tang, J.W., Bennett, J., Kyriakou, C., Peggs, K., Cubitt, D., Brink, N.S., Ward, K.N. and Tedder, R.S. (2005) First reported outbreak of diarrhea due to adenovirus infection in a hematology unit for adults, *J. Clin. Microbiol.*, **43**, 2575–2580.
- Kantor, H.S., Poblete, R. and Pusateri, S.L. (1988) Nosocomial transmission of tuberculosis from unsuspected disease, *Am. J. Med.*, **84**, 833–838.
- Kenyon, T.A., Valway, S.E., Ihle, W.W., Onorato, I.M. and Castro, K.G. (1996) Transmission of multidrug-resistant *Mycobacterium tuberculosis* during a long airplane flight, *N. Engl. J. Med.*, **334**, 933–938.
- Kreiss, K. (1990) The sick building syndrome: where is the epidemiologic basis?, *Am. J. Public Health*, **80**, 1172–1173.
- Kroenke, K. (1998) Building-related illnesses, *N. Engl. J. Med.*, **338**, 1070–1071.
- Kumari, D.N.P., Haji, T.C., Keer, V., Hawkey, P.M., Duncanson, V. and Flower, E. (1998) Ventilation grilles as a potential source of methicillin-resistant *Staphylococcus aureus* causing an outbreak in an orthopaedic ward at a district general hospital, *J. Hosp. Infect.*, **39**, 127–133.
- Langmuir, A.D. (1961) Epidemiology of airborne infection, *Bacteriol. Rev.*, **25**, 173–181.
- Langmuir, A.D. (1980) Changing concepts of airborne infection of acute contagious diseases: a reconsideration of classic epidemiologic theories, *Ann. N. Y. Acad. Sci.*, **353**, 35–44.
- Le, D.H., Bloom, S.A., Nguyen, Q.H., Maloney, S.A., Le, Q.M., Leitmeyer, K.C., Bach, H.A., Reynolds, M.G., Montgomery, J.M., Comer, J.A., Horby, P.W. and Plant, A.J. (2004) Lack of SARS transmission among public hospital workers, Vietnam, *Emerg. Infect. Dis.*, **10**, 265–268.
- Leclair, J.M., Zaia, J.A., Levin, M.J., Congdon, R.G. and Goldmann, D.A. (1980) Airborne transmission of chickenpox in a hospital, *N. Engl. J. Med.*, **302**, 450–453.
- Letz, G.A. (1990) Sick building syndrome: acute illness among office workers – the role of building ventilation, airborne contaminants and work stress, *Allergy Proc.*, **11**, 109–116.
- Leung, C.C., Yew, W.W., Tam, C.M., Chan, C.K., Chang, K.C., Law, W.S., Wong, M.Y. and Au, K.F. (2004) Socio-economic factors and tuberculosis: a district-based ecological analysis in Hong Kong, *Int. J. Tuberc. Lung Dis.*, **8**, 958–964.
- Li, Y., Huang, X., Yu, I.T., Wong, T.W. and Qian, H. (2005a) Role of air distribution in SARS transmission during the largest nosocomial outbreak in Hong Kong, *Indoor Air*, **15**, 83–95.
- Li, Y., Duan, S., Yu, I.T.S. and Wong, T.W. (2005b) Multi-zone modeling of probable SARS virus transmission by airflow between flats in Block E, Amoy Gardens, *Indoor Air*, **15**, 96–111.
- Lidwell, O.M., Brock, B., Shooter, R.A., Cooke, E.M. and Thomas, G.E. (1975) Airborne infection in a fully air-conditioned hospital: IV – airborne dispersal of *Staphylococcus aureus* and its nasal acquisition by patients, *J. Hyg. (London)*, **75**, 445–474.
- Mangili, A. and Gendreau, M.A. (2005) Transmission of infectious diseases during commercial air travel, *Lancet*, **365**, 989–996.
- Mastorides, S.M., Oehler, R.L., Greene, J.N., Sinnott, J.T. and Sandin, R.L. (1997) Detection of airborne *Mycobacterium tuberculosis* by air filtration and polymerase chain reaction, *Clin. Infect. Dis.*, **25**, 756–757.
- Mastorides, S.M., Oehler, R.L., Greene, J.N., Sinnott, J.T., 4th, Kranik, M. and Sandin, R.L. (1999) The detection of airborne *Mycobacterium tuberculosis* using micropore membrane air sampling and polymerase chain reaction, *Chest*, **115**, 19–25.
- Menzies, D. and Bourbeau, J. (1997) Building-related illnesses, *N. Engl. J. Med.*, **337**, 1524–1531.
- Menzies, D., Fanning, A., Yuan, L. and FitzGerald, J.M. (2000) Hospital ventilation and risk for tuberculous infection in Canadian health care workers, *Ann. Int. Med.*, **133**, 779–789.
- Mercer, A.J. (1986) Relative trends in mortality from related respiratory and airborne infectious diseases, *Popul. Stud. (Cambridge)*, **40**, 129–145.
- Meselson, M., Guillemin, J., Hugh-Jones, M., Langmuir, A., Popova, I., Shelokov, A. and Yampolskaya, O. (1994) The Sverdlovsk anthrax outbreak of 1979, *Science*, **266**, 1202–1208.
- Moser, M.R., Bender, T.R., Margolis, H.S., Noble, G.R., Kendal, A.P. and Ritter, D.G. (1979) An outbreak of influenza aboard a commercial airliner, *Am. J. Epidemiol.*, **110**, 1–6.
- Myatt, T.A., Johnston, S.L., Rudnick, S. and Milton, D.K. (2003) Airborne rhinovirus detection and effect of ultraviolet irradiation on detection by a semi-nested RT-PCR assay, *BMC Public Health*, **3**, 5–11.
- Myatt, T.A., Johnston, S.L., Zuo, Z., Wand, M., Kebedze, T., Rudnick, S. and Milton, D.K. (2004) Detection of airborne rhinovirus and its relation to outdoor air supply in office environments, *Am. J. Respir. Crit. Care Med.*, **169**, 1187–1190.
- Nardell, E.A. (1993) Fans, filters or rays? Pros and cons of the current environmental tuberculosis control technologies, *Infect. Control Hosp. Epidemiol.*, **14**, 681–685.
- Nardell, E.A., Keegan, J., Cheney, S.A. and Etkind, S.C. (1991) Airborne infection: theoretical limits of protection achievable by building ventilation, *Am. Rev. Respir. Dis.*, **144**, 302–306.
- NHS Estates (1994) *Ventilation of Healthcare Premises, Hospital Technical Memorandum (HTM) 2025*, London, UK, Department of Health.
- Olsen, S.J., Chang, H.L., Cheung, T.Y., Tang, A.F., Fisk, T.L., Ooi, S.P., Kuo, H.W., Jiang, D.D., Chen, K.T., Lando, J., Hsu, K.H., Chen, T.J. and Dowell, S.F. (2003) Transmission of the severe acute respiratory syndrome on aircraft, *N. Engl. J. Med.*, **349**, 2416–2422.
- Papinen, R.S. and Rosenthal, F.S. (1997) The size distribution of droplets in the exhaled breath of healthy human subjects, *J. Aerosol Med.*, **10**, 105–116.
- Redlich, C.A., Sparer, J. and Cullen, M.R. (1997) Sick-building syndrome, *Lancet*, **349**, 1013–1016.
- Reinhard, C., Paul, W.S. and McAuley, J.B. (1997) Epidemiology of pediatric tuberculosis in Chicago, 1974–1994: a continuing public health problem, *Am. J. Med. Sci.*, **313**, 336–340.
- Remington, P.L., Hall, W.N., Davis, I.H., Herald, A. and Gunn, R.A. (1985) Airborne transmission of measles in a physician's office, *JAMA*, **253**, 1574–1577.
- Rice, N., Streifel, A. and Vesley, D. (2001) An evaluation of hospital special-ventilation-room pressures, *Infect. Control Hosp. Epidemiol.*, **22**, 19–23.
- Riley, R.L. (1979) Indoor spread of respiratory infection by recirculation of air, *Bull. Eur. Physiopathol. Respir.*, **15**, 699–705.
- Riley, R.L. and O'Grady, F. (1961) *Airborne Infection – Transmission and Control*, New York, The MacMillan Company.
- Riley, R.L., Mills, C.C., O'Grady, F., Sultan, L.U., Wittstadt, F. and Shivpuri, D.N. (1962) Infectiousness of air from a tuberculosis ward: ultraviolet irradiation of infected air: comparative infectiousness of different patients, *Am. Rev. Respir. Dis.*, **85**, 511–525.
- Riley, E.C., Murphy, G. and Riley, R.L. (1978) Airborne spread of measles in a suburban elementary school, *Am. J. Epidemiol.*, **107**, 421–432.
- Rossi, G.L., Corsico, A., Roggeri, A. and Moscato, G. (1991) Human health and air conditioning systems, *G. Ital. Med. Lav.*, **13**, 51–54.
- Rutala, W.A., Jones, S.M., Worthington, J.M., Reist, P.C. and Weber, D.J. (1995) Efficacy of portable filtration units in re-



- ducing aerosolized particles in the size range of *Mycobacterium tuberculosis*, *Infect. Control. Hosp. Epidemiol.*, **16**, 391–398.
- Schafer, M.P., Martinez, K.F. and Mathews, E.S. (2003) Rapid detection and determination of the aerodynamic size range of airborne mycobacteria associated with whirlpools, *Appl. Occup. Environ. Hyg.*, **18**, 41–50.
- Schulman, J.L. and Kilbourne, E.D. (1962) Airborne transmission of influenza virus infection in mice, *Nature*, **195**, 1129–1130.
- Seppanen, O.A., Fisk, W.J. and Mendell, M.J. (1999) Association of ventilation rates and CO<sub>2</sub> concentrations with health and other responses in commercial and institutional buildings, *Indoor Air*, **9**, 226–252.
- Sheretz, R.J., Belani, A. and Kramer, B.S. (1987) Impact of air filtration on nosocomial *Aspergillus* infections, *Am. J. Med.*, **83**, 709–718.
- Sherin, K.M. (1993) Building-related illnesses and sick building syndrome, *J. Fla. Med. Assoc.*, **80**, 472–474.
- Shigematsu, I. and Minowa, M. (1985) Indoor infection in a modern building, *Tokai J. Exp. Clin. Med.*, **10**, 407–413.
- Strausbaugh, L.J., Sukumar, S.R. and Joseph, C.L. (2003) Infectious disease outbreaks in nursing homes: an unappreciated hazard for frail elderly persons, *Clin. Infect. Dis.*, **36**, 870–876.
- Sundell, J. (2004) On the history of indoor air quality and health, *Indoor Air*, **14** (Suppl. 7), 51–58.
- Tang, J.W., Eames, I., Li, Y., Taha, Y.A., Wilson, P., Bellingan, G., Ward, K.N. and Breuer, J. (2005) Door-opening motion can potentially lead to a transient breakdown in negative-pressure isolation conditions: the importance of vorticity and buoyancy airflows, *J. Hosp. Infect.*, **61**, 283–286.
- Ussery, X.T., Bierman, J.A., Valway, S.E., Seitz, T.A., DiFerdinando, G.T. Jr. and Ostroff, S.M. (1995) Transmission of multidrug-resistant *Mycobacterium tuberculosis* among persons exposed in a medical examiner's office, New York, *Infect. Control Hosp. Epidemiol.*, **16**, 160–165.
- Vadrot, C., Bex, V., Mouilleseaux, A., Squinazi, F. and Darbord, J.C. (2004) Detection of *Mycobacterium tuberculosis* complex by PCR in hospital air samples, *J. Hosp. Infect.*, **58**, 262–267.
- Wan, G.H., Lu, S.C. and Tsai, Y.H. (2004) Polymerase chain reaction used for the detection of airborne *Mycobacterium tuberculosis* in health care settings, *Am. J. Infect. Control*, **32**, 17–22.
- Wargocki, P., Sundell, J., Bischof, W., Brundrett, G., Fanger, P.O., Gyntelberg, F., Hanssen, S.O., Harrison, P., Pickering, A., Seppänen, O. and Wouters, P. (2002) Ventilation and health in non-industrial indoor environments: report from a European Multidisciplinary Scientific Consensus Meeting (EUROVEN), *Indoor Air*, **12**, 113–128.
- Wehrle, P.F., Posch, J., Richter, K.H. and Henderson, D.A. (1970) An airborne outbreak of smallpox in a German hospital and its significance with respect to other recent outbreaks in Europe, *Bull. World Health. Organ.*, **43**, 669–679.
- Weiss, R.A. and McMichael, A.J. (2004) Social and environmental risk factors in the emergence of infectious diseases, *Nat. Med.*, **10** (Suppl. 12), S70–S76.
- Wells, W.F. (1934) On air-borne infection study: II – droplets and droplet nuclei, *Am. J. Hyg.*, **20**, 619–627.
- Wells, W.F. (1955) *Airborne Contagion and Air Hygiene: an Ecological Study of Droplet Infection*, Cambridge, MA, Harvard University Press.
- Wong, T.W., Li, C.K., Tam, W., Lau, J.T.F., Yu, T.S., Lui, S.F., Chan, P.K.S., Li, Y.G., Bresee, J.S., Sung, J.Y. and Parashar, U.D. (2004) Cluster of SARS among medical students exposed to single patient, Hong Kong, *Emerg. Infect. Dis.*, **10**, 269–276.
- Xiao, W.J., Wang, M.L., Wei, W., Wang, J., Zhao, J.J., Yi, B. and Li, J.S. (2004) Detection of SARS-CoV and RNA on aerosol samples from SARS-patients admitted to hospital, *Chin. J. Epidemiol.*, **25**, 882–885 (in Chinese).
- Yu, I.T., Li, Y., Wong, T.W., Tam, W., Chan, A.T., Lee, J.H., Leung, D.Y. and Ho, T. (2004) Evidence of airborne transmission of the severe acute respiratory syndrome virus, *N. Engl. J. Med.*, **350**, 1731–1739.
- Yu, I.T.S., Wong, T.W., Chiu, Y.L., Lee, N. and Li, Y. (2005) Temporal-spatial analysis of severe acute respiratory syndrome among hospital inpatients, *Clin. Infect. Dis.*, **40**, 1237–1243.
- Zhong, N.S., Zheng, B.J., Li, Y.M., Poon, L., Xie, Z.H., Chan, K.H., Li, P.H., Tan, S.Y., Chang, Q., Xie, J.P., Liu, X.Q., Xu, J., Li, D.X., Yuen, K.Y., Peiris and Guan, Y. (2003) Epidemiology and cause of severe acute respiratory syndrome (SARS) in Guangdong, People's Republic of China, in February, 2003, *Lancet*, **362**, 1353–1358.
- Zitter, J.N., Mazonson, P.D., Miller, D.P., Hulley, S.B. and Balmes, J.R. (2002) Aircraft cabin air recirculation and symptoms of the common cold, *JAMA*, **288**, 483–486.
- Zwingle, E. (2002) Megacities, *Natl. Geogr. Mag.*, **202**, 70–99.

**TAB 5**

**TAB 5A**



# ASHRAE EPIDEMIC TASK FORCE

SCHOOLS & UNIVERSITIES | Updated 7-17-2020



## Introduction

### Determining Building Readiness

- Summer Checklist for Fall Classes
- Startup Checklist for HVAC Systems Prior to Occupancy

## New/Modified Facility Design Recommendations

- Introduction
- Designer Guidelines – General School
- Nurses Office – General Requirements

## Equipment & System Specific Checks & Verifications During Academic Year

- Cleaning & Air Flush
- Boilers
- Chilled, Hot & Condenser Water Systems
- Air Cooled Chillers
- Water Cooled Chillers
- Cooling Towers & Evaporative-Cooled Devices
- Steam Distribution Systems
- HVAC Water Distribution Systems
- Pumps
- Air Handling Units
- Roof Top Units
- Unitary & Single Zone Equipment

## Filtration Upgrades

- Introduction
- Filtration Basics
- Filtration Target Level
- Information Gathering Stage
- Data Analysis & Review
- Implementation & Considerations

## Operation of Occupied Facilities

### Controlling Infection Outbreak in School Facilities

## Higher Education Facilities

- Student Health Facilities
- Laboratories
- Athletic Facilities
- Residence Facilities
- Large Assembly



# Introduction



Protecting the health, safety and welfare of the world's students from the spread of SARS-Cov-2 (the virus that causes COVID-19 disease) is essential to protecting the health, safety and welfare of the entire population.

ASHRAE's position is that "Transmission of SARS-CoV-2 through the air is sufficiently likely that airborne exposure to the virus should be controlled. Changes to building operations, including the operation of heating, ventilating, and air-conditioning [HVAC] systems, can reduce airborne exposures."

There is broad variation of complexity, flexibility, and age in HVAC equipment, systems, controls and Building Automation Systems (BAS) in educational facilities.

**This guidance has been formulated to help designers retrofit and plan for the improvement of indoor air quality and to slow the transmission of viruses via the HVAC systems. The underlying effort of the designer should be to increase outside air to the spaces and treat return air. The designer should also be concerned with mechanical filtration of the supply air and maintaining indoor comfort as defined by the design temperature and relative humidity.**

**This guidance should be applied to each unique climate zone, unique school building and HVAC system. All retrofits and modifications must not contradict ASHRAE 62.1 guidelines and must continue to or exceed the standards and codes adopted by local jurisdictions. The designer needs to work closely with the local school system to work in conjunction with new operational protocols and school operations.**

The following is meant to provide practical information and checklists to school district and university campus environmental health managers, facility managers, administrators, technicians, and service providers to prepare educational buildings to resume occupancy. This information describes how the HVAC systems should be operating to help minimize the chance of spreading SARS-Cov-2 and how to practically check/verify that operation.



# Determining Building Readiness and Operations for Existing Facilities to Reoccupy After Shut-Down due to Pandemic



**These recommendations and strategies are organized in order from simple first steps, more involved next steps and then more long-term improvements**

1. Create a District or Campus Health and Safety Committee that includes all stakeholders (environmental health and safety, administration, education staff, operations staff, local healthcare providers, etc.)
2. Develop policies for staff and contractor PPE requirements for completing work at facilities that follow local authority, [CDC](#), and [OSHA](#) guidelines for the proper use of Personal Protective Equipment (PPE).
3. Where semi-annual / annual scheduled maintenance on the equipment can be performed safely, do not defer this maintenance cycle.
4. Where worker safety could be at risk, defer semi-annual/ annual maintenance on the equipment up to 60 days until worker safety can be accomplished.
5. During the summer period before occupancy perform Checklist No. 1 Summer Checklist for Fall Start of Classes.
6. Operate all HVAC in occupied mode for a minimum of one week prior to occupancy.
7. During the week prior to occupancy perform Checklist No. 2 Startup Checklist for HVAC Systems Prior to Occupancy.





# Checklist No. 1: Summer Checklist for Fall Start of Classes



- Review design guidance for potential system modifications to comply with this guidance.
- Review air distribution conditions of existing spaces (look for covered diffusers, blocked return grilles, overly closed supply diffusers/registers and return/exhaust grilles creating short cycling, possible measurements of airflows by commissioning or balancing professionals, possible review of overall system configuration by design professional, etc.)
- Review existing Indoor Air Quality issues, if any, records of documents and investigate current status of complaint and address any deficiencies identified, if possible.
- General inspection of spaces to identify any potential concerns for water leaks or mold growth that could negatively impact occupant health.
- Check all lavatories and sinks for correct operation and ensure soap dispensers are functional and adequate supply of soap is available to allow for proper handwashing.
- Coordinate with local utilities to identify when buildings will be restarted, identify when systems will be operated (if different than prior operations) and identify that demands may increase (primarily electric but gas may apply as well for some facilities).
- Consider completing preventative and deferred maintenance projects not directly related to pandemic, but potentially improving facility IEQ:
  - Clean/disinfect building surfaces, focusing on high touch surfaces – secure spaces from access once cleaning is complete.
  - Consider asbestos abatement work if applicable.
  - Consider lead paint abatement work if applicable.
  - Consider access improvements, including repairs to walkways and ramps, ADA upgrades, handrail repairs, etc.
  - Consider grounds work including improvement of water drainage away from buildings, planting of native plants or trees to help control water penetration into ground and shading of facilities to reduce cooling load.
- Review control sequences to verify systems are operating according to this guidance to maintain required ventilation, temperature and humidity conditions to occupied areas.

# Checklist No. 2:

## Startup Checklist for HVAC Systems Prior to Occupancy



- Maintain proper indoor air temperature and humidity to maintain human comfort, reduce potential for spread of airborne pathogens and limit potential for mold growth in building structure and finishes (refer to [ASHRAE Standard 55](#), recommended temperature ranges of 68-78 degrees F dry bulb depending on operating condition and other factors, recommend limiting maximum RH to 60%). Consider consulting with a local professional engineer to determine appropriate minimum RH levels based on local climate conditions, type of construction and age of the building under consideration. Recommend minimum RH of 40% if appropriate for building. Consider the addition of humidification equipment only when reviewed by a design professional to verify minimum RH set points will not adversely impact building or occupants by contributing to condensation and possible biological growth in building envelope.
- Trend and monitor temperature and humidity levels in each space to the extent possible and within the capability of BAS, portable data loggers and handheld instruments.
- Verify proper separation between outdoor air intakes and exhaust discharge outlets to prevent/limit re-entrainment of potentially contaminated exhaust air (generally minimum of 10-foot separation - comply with local code requirements).
- Consider having airflows and building pressurization measured/balanced by a qualified Testing, Adjusting and Balancing (TAB) service provider.
- Consider having airflows and system capacities reviewed by design professionals to determine if additional ventilation can be provided without adversely impacting equipment performance and building Indoor Environmental Quality (IEQ).
- Measure building pressure relative to the outdoors. Adjust building air flows to prevent negative pressure differential.
- Verify coil velocities and coil and unit discharge air temperatures required to maintain desired indoor conditions and to avoid moisture carry over from cooling coils.
- Review outdoor airflow rates compared to the most current version of [ASHRAE Standard 62.1](#) or current state-adopted code requirements.





# Checklist No. 2 Continued:

## Startup Checklist for HVAC Systems Prior to Occupancy



- **Filtration in all mechanical equipment:**

- Verify filters are installed correctly.
- Develop standards for frequency of filter replacement and type of filters to be utilized.
- Select filtration levels (MERV ratings) that are maximized for equipment capabilities, use MERV 13 if equipment allows, while assuring the pressure drop is less than the fans capability. [See Filtration Upgrades.](#)

- If Demand-Controlled Ventilation (DCV) systems using Carbon Dioxide (CO2) sensors are installed, operate systems to maintain maximum CO2 concentrations of 800-1,000 Parts Per Million (ppm) in occupied spaces:**

- Trend and monitor levels continuously if controls system is capable of doing so (use portable data loggers and handheld instruments and document readings where needed to demonstrate compliance with District or Campus requirements).
- Consider adjusting to maximize outdoor air or disabling operation of DCV if it will not adversely impact operation of overall system (Temporary recommendation while operating under infectious disease crisis).

- Perform initial air flush of all spaces prior to occupants re-entering building:**

- Mechanical systems should operate in occupied mode for minimum period of one week prior to students returning (may be completed at same time as teachers start returning to building) while assuring the outside air dampers are open.

- Domestic water systems shall be prepared for use:**

- Systems should be flushed to remove potential contaminants from stagnant equipment, piping, fixtures, etc.
- Domestic cold-water systems should be flushed with all fixtures on a branch of piping opened simultaneously for a minimum period of five minutes – preferred approach is to have all building fixtures open at same time if possible – if not, care should be taken to ensure flow rate is adequate to flush piping mains and branch lines.
- Domestic hot water systems should be flushed with all fixtures on a branch of piping opened simultaneously for a minimum period of 15 minutes – preferred approach is to have all building fixtures open at same time if possible – if not, care should be taken to ensure flow rate is adequate to flush piping mains and branch lines.
- Reference [Standard 188](#) and Guideline 12 (available read-only on website)



# Equipment and System Specific Checks and Verifications During the Academic Year



## Cleaning and Air Flush: Daily

- Daily flush prior to occupancy: Mechanical Systems should be operated in occupied mode (including normal or peak outside air rate introduced to each space) for minimum period of 2 hours prior to occupants re-entering building.
- Cleaning:
  - All areas that have been occupied after previous cleaning efforts should be re-cleaned.
  - All restrooms should be thoroughly cleaned.
  - All food preparation areas should be thoroughly cleaned.
  - Any spaces not previously cleaned should have all accessible surfaces properly cleaned.

## Boilers: Monthly

- For systems with Steam Boilers, develop a schedule that provides minimum supervision on-site.
- Perform chemical testing of system water. Verify water treatment target levels are being maintained.
- For systems using fuel oil:
  - Check fuel pump for proper operation.
  - Inspect fuel filter; clean and verify proper operation.
- For systems using natural gas:
  - Check gas pressure, gas valve operation, and combustion fan operation.
  - Check for evidence of leakage of fuel supply, heat transfer fluid, and flue gas.
- Verify proper operation of safety devices per manufacturer's recommendations.



# Equipment and System Specific Checks and Verifications During the Academic Year Continued



## Chilled Water, Hot Water and Condenser Water Systems: Monthly

- Perform chemical testing of system water. Verify water treatment target levels are being maintained.
- Check the control system and devices for evidence of improper operation.
- Verify control valves operate properly.
- Check variable-frequency drives for proper operation.

## Air Cooled Chillers: Monthly

- Check the refrigerant system for evidence of leaks.
- Check and clean fan blades and fan housing.
- Check coil fins and check for damage.
- Check for proper evaporator fluid flow and for fluid leaks.

## Water Cooled Chillers: Monthly

- Check the refrigerant system for evidence of leaks.
- Check for proper evaporator and condenser fluid flow and for fluid leaks.
- Check compressor oil level and/or pressure on refrigerant systems having oil level and/or pressure measurement means.



# Equipment and System Specific Checks and Verifications During the Academic Year Continued



## Cooling Towers and Evaporative-Cooled Devices Monthly

- Perform chemical testing of system water. Verify water treatment target levels are being maintained.
- Check chemical injector device for proper operation.
- Check conductivity and other sensors for proper readings.
- Check the water system ultraviolet lamp, replace bulbs as needed (if applicable).
- Check the control system and devices for evidence of improper operation.
- Check variable frequency drive for proper operation.
- Check for proper condenser water flow and for leaks.
- Check for proper damper operation.
- Inspect pumps and associated electrical components for leaks and normal operation.
- Verify control valves operate properly.

## Steam Distribution Systems: Monthly

- Perform chemical testing of system condensate and feed water.
- Check piping for leaks.
- Check steam traps and condensate return units for proper operation.
- Check safety devices per manufacturer's recommendations.
- Verify control valves operate properly.





# Equipment and System Specific Checks and Verifications During the Academic Year Continued



## HVAC Water Distribution Systems: Monthly

- Perform chemical testing of system water. Verify water treatment target levels are being maintained.
- Check for proper fluid flow and for fluid leaks. If necessary, vent air from system high points and
- verify backflow preventers and pressure regulating valves on makeup water lines are functioning properly.
- Check expansion tanks and bladder type compression tanks have not become waterlogged.
- Verify control valves operate properly.

## Pumps: Annually

- Inspect pumps and associated electrical components for proper operation.
- Check variable-frequency drive for proper operation.
- Check the control system and devices for evidence of improper operation.



# Equipment and System Specific Checks and Verifications During the Academic Year Continued



## Air Handling Units: Monthly

- Check for particulate accumulation on filters, replace filter as needed.
- Check ultraviolet lamp, replace bulbs as needed (if applicable).
- Check P-trap on drain pan.
- Check the control system and devices for evidence of improper operation.
- Check variable-frequency drive for proper operation.
- Check drain pans for cleanliness and proper slope.
- Verify control dampers operate properly.
- Confirm AHU is bringing in outdoor air and removing exhaust air as intended.
- Verify filters are installed correctly.
- Follow filter replacement policy.
- Review condition of cooling coils in air handling equipment – if issues with condensate drainage are identified or biological growth is identified, corrective action should be taken to clean or repair.

# Equipment and System Specific Checks and Verifications During the Academic Year Continued



## Roof Top Units: Monthly

- Check for particulate accumulation on outside air intake screens and filters. Replace filter as needed.
- Check ultraviolet lamp, replace bulbs as needed (if applicable).
- Check P-trap.
- Check drain pans for cleanliness and proper slope.
- Check the control system and devices for evidence of improper operation.
- Check variable frequency drive for proper operation.
- Check refrigerant system for leaks.
- Check for evidence of leaks on gas heat section heat-exchanger surfaces.
- For fans with belt drives, inspect belts and adjust as necessary.
- Verify control dampers operate properly.

# Equipment and System Specific Checks and Verifications During the Academic Year Continued



**Unitary and Single Zone Equipment** (For example: Wall Hung Units, Unit Ventilators, Mini-Splits, Packaged Terminal Air Conditioners, Water-Source Heat Pumps, Fan Coil Units):

## Monthly

- Check for particulate accumulation on filters, replace filter as needed.
- Check P-trap.
- Check drain pans for cleanliness and proper slope.
- Check the control system and devices for evidence of improper operation.
- Verify control dampers operate properly.





# New/Modified Facility Design Recommendations



## Introduction

This guidance has been formulated to help designers retrofit and plan for the improvement of indoor air quality and to slow the transmission of viruses via the HVAC systems. The underlying effort of the designer should be to increase outside air to the spaces, treat return air and or supply air to spaces via mechanical filtration and maintain indoor comfort as defined by the design temperature and relative humidity.

This guidance should be applied to each unique climate zone, unique school building and HVAC system. All retrofits and modifications must not contradict [ASHRAE 62.1 guidelines](#) and must continue to meet or exceed applicable codes and standards. The designer needs to work closely with the local school system to work in conjunctions with new operational protocols and school operations.

Nurse office suite design should follow health care facilities design practices as described in standards such as [ASHRAE Standard 170](#) and other applicable guidelines and design information.



# Designer Guidelines – General School



## Temperature and Humidity Design Criteria

### 1. Winter classroom design guidelines 72 F/40- 50% RH

- 40- 50% RH in winter is primary guidance via humidifiers/active humidification (central or local, depending on the classroom/space system). The humidity minimum, humidifier, and sensor location should be made after consultation with your ASHRAE professional regarding the envelope design due to the potential for condensation within the building envelope.

### 2. Summer classroom design guidelines 75 F/50%-60% RH

Designing to 50% RH in summer is primary guidance, depending on the classroom system.

## Ventilation Design Criteria/Guideline

- Follow current [ASHRAE 62 standard](#) or local ventilation standards for minimum outside air requirements.
- For remodeling an existing AHU, increase outside air to maximum allowable per Air Handling Unit (AHU) without compromising indoor thermal comfort for learning environment (due to severe thermal outdoor air conditions) or space IAQ due to poor outdoor ambient conditions (pollution).
- For Dedicated Outdoor Air Systems (DOAS) that are being replaced, size unit capacity for at least 150% of code minimum flow.
- During the Pandemic, disable any Demand Control Ventilation (DCV) and introduce the maximum possible OA flow 24/7 until further notice (including DOAS).
- Apply and utilize outdoor air quality sensors or reliable web-based data for outdoor pollution information as part of the new ventilation operation.



# Designer Guidelines – General School

## Continued



### Filtration Design Criteria/ Guideline

#### 1. Follow 2019 ASHRAE- Applications Handbook, chapter 8, table 7 for minimum Filtration Efficiency

- Apply the highest Minimum Efficiency Reporting Value (MERV) applicable for the HVAC units (local, central and DOAS). HEPA or MERV 13 is recommended minimum if equipment can accommodate pressure drop and MERV 14 is preferred.

#### 2. Introduce portable, all electric HEPA/UV Machines in each classroom

- Guideline minimum of 2 Air rotations/hour
- Ensure flow patterns maximize mixing of air in classrooms

### Operation and Scheduling Guideline for Existing AHUs during the Pandemic

#### 1. Cooling and Heating equipment- Change the start of operation hours (e.g. change 6 am start to 4 am) and run DOAS

- Cooling and Heating systems (Local, central)- Goal is to create a thermal lag and minimize HVAC operations when occupied
- DOAS Systems - Run DOAS units two hours before and after occupancy.

#### 2. Exhaust fans- Turn on when DOAS is running

- Only applies to school days not weekend operations
- Goal is to flush the building with OA and positively pressurize the building

#### 3. Dedicated Outdoor Air Systems (DOAS) – Create “Minimum Transmission Sequence of Operation”

- DOAS Systems - Run DOAS units two hours before and after occupancy as part of new DOAS sequence of Operation
- For DOAS units equipped with active, thermally operated desiccant dehumidifier, consult the manufacturer for safe operation.
- For new installations, designer should designate a “Purge/Flush” mode for operations to minimize the virus transmission via HVAC systems.

#### 4. Energy Recovery Systems

- Many air handling system types (central air handling units, DOAS units, terminal systems, etc.) include Energy Recovery Ventilation (ERV) systems (these can include energy recovery wheels, plate-type heat exchangers, heat pipes, run around loops, etc.)
- Some types or configurations for energy recovery systems allow for exhaust air transfer from the exhaust airstream to the supply airstream, while others do not – depending on system configuration this may be cause for concern
- A document focused on operational considerations for energy recovery systems for many system types and configurations is available [here](#).

# Designer Guidelines – General School Continued



## 4. AHU's (SZ and VAV) and Packaged Rooftop units (PSZ, PVAV)

- During the Pandemic, increase Filtration to that recommended in the Filtration Upgrade section below.
- For existing units, an increase in filtration efficiency may reduce airflow capacity. Compensate for loss of capacity in winter with portable plug in elec. Heaters or higher discharge temps.
- Compensate for loss of capacity in summer with lower discharge temps off of AHU – recommend 52 F (this is mainly for VAV units where supply air temperature is controlled and due to additional pressure drop associated with higher efficiency filters).
- Check and fix economizer dampers and controls and maximize the economizer operation when possible (favorable outdoor conditions and outdoor air pollution).
- Check, fix and modify control sequences in VAV systems to avoid outdoor air flow /minimum OA air flow shortage.
- In VAV systems maximize the total supply air flow in each VAV terminal when the system is in full economizer mode.
- Minimize the unit air recirculation to minimize zones cross contamination thru the return air system.
- Install UV/C lights, ionization in AHU's – UV min 1500 microwatts/cm<sup>2</sup> when possible. UV/C lights a destructive to filter media. Ensure no UV lights shall shine on filters.
- Install Humidifiers in AHUs and Packaged rooftop units if possible.
- Install duct mounted humidifiers at classrooms as an alternate.

## 5. Local HVAC units (Fan Coils, WSHP, GSHP, Mini Split, VRF, Unit Ventilators, Radiators/baseboards)

- Increase Filtration to the maximum MERV suggested by the manufacturer.
- Compensate for loss of capacity in winter with portable plug in electric heaters or higher discharge temps.
- Hydronic /Electric radiators / baseboard can remain operational.
- Check unit ventilators for proper amounts of OA and operation.
- Install Portable humidifiers in each classroom for local humidity control.

## 6. Space Air Flow

- Ensure airflow patterns in classrooms are adjusted to minimize occupant exposure to particles.
- Recommended guidance is to provide lowest possible particulate concentration anywhere in the space.





# Nurses Office – General Requirements



- Treat as Isolation rooms – 1 bed per building – follow [ASHRAE 170](#) and [2019 ASHRAE Handbook Chapter 9](#).
- If retrofits are not possible recommend temporary nurse's station trailers.
- Dedicated bathrooms.
- The nurse station will include Anteroom/Protective Equipment Room.
- Normal non-isolation nursing office.
- Provisions for Biohazard waste.
- Two (2) modes of operation, (1) "Isolation Mode and (2) "Normal Mode"
- For "Isolation mode" design Dedicated HVAC system.
- For the "Normal Mode" the HVAC system can be (supplementary) standard HVAC system (VRF +DOAS, Fan coils, WSHP/GSHP, DOAS etc) with current design practices ([ASHRAE 62.1](#), [ASHRAE 90.1](#) and local codes etc).
- The HVAC operation will be "Isolation mode" OR "Normal Mode".
- Follow CDC guidelines for supply air return air paths, do not mix isolation room air with any other spaces. Directly exhaust isolation rooms. Follow design guidelines for location of OA intakes and exhaust air from exhaust fans.
- Recommend locations of nurse's office HVAC on an exterior wall.
- Maintain pressure relationship for room, ante room and corridor.

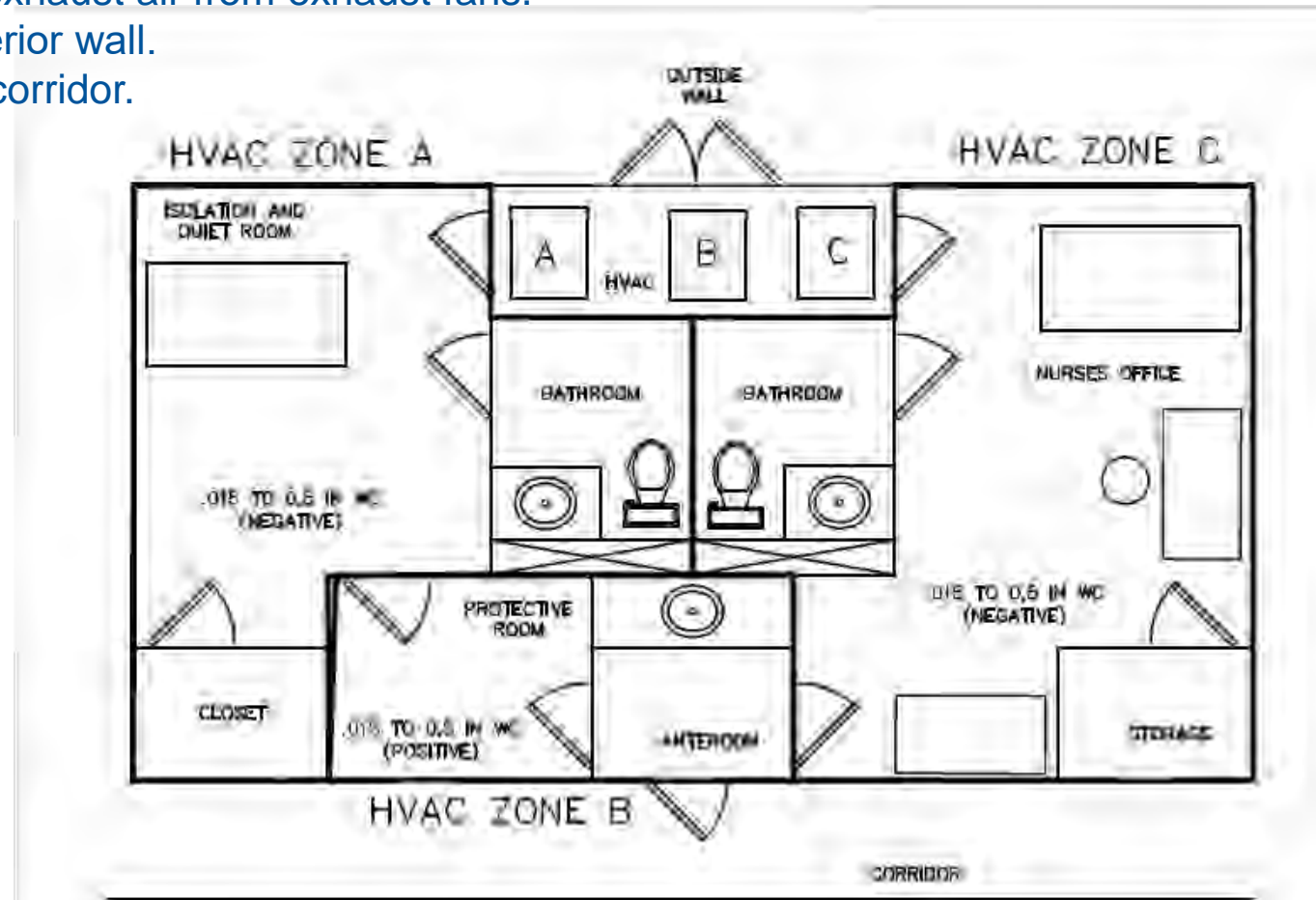

**Note:** Systems A, B, and C are the Dedicated "Isolation Mode" systems, each system is individually operated and controlled. The Supplementary HVAC systems for "Normal mode" are not shown.

# Nurses Office – General Requirements Continued



## Temperature and Humidity Design Criteria- Isolation Mode

- Winter Nurse Station design guidelines 72 F/50-55% RH
- Summer Nurse Station design guidelines 72 F/50%-60% RH

## Ventilation Design Criteria/Guideline- Isolation Mode

- 100 % OA system
- Design for a maximum of 10 Air Changes per Hour (ACH), can operate at 6 ACH

## Filtration Design Criteria/ Guideline- Isolation Mode

- Follow [ASHRAE 170](#), table 6.4 – Protective Environment (PE) room filter guidelines
  - Two filter banks, MERV 7 and HEPA (MERV 14 for existing HVAC that is unable to support HEPA)

## Space Pressurization Design Criteria/ Guideline- Isolation Mode

- Follow [ASHRAE 170](#), section 7.2 and other related sections for space pressure requirements
  - Isolation Room and Nurse office will be Negative Pressure (- 0.015” to – 0.5” W.C)
  - Protective Room will be Positive Pressure ((+ 0.015” to + 0.5” W.C)
  - Given the small size of the systems serving the Nurse Station in Isolation Mode, it is suggested considering Constant Volume, hard balanced air system.

## Space Air Distribution/Diffusion Design Criteria/ Guideline- Isolation Mode

- Follow [ASHRAE 170](#), Table 6.7.2 – PE Group E non-aspirating (for additional information refer to 2017 ASHRAE – Fundamentals, chapter 20).



# Nurses Office – General Requirements Continued



## General Design Parameters- Isolation Mode

- [Follow ASHRAE 170](#), Table 7-1
  - Treat as PE anteroom and combination All/PE.
  - ACH = 10.
  - Exhaust directly to outdoors
  - No air re-circulation
  - All should be under negative pressure.
  - PE rooms with respect to adjacent rooms should be under positive pressure.
- [Follow ASHRAE 170](#), section 7.2.1.
  - Infection Control Risk Assessment (ICRA) is to be performed for new construction and renovations of nurse facilities.
  - Refer to guidance on ICRA for renovations and creating a CX plan and well as phasing the construction.
- [Follow ASHRAE 170](#), Section 6.8.2 which refers to energy recovery.
  - No energy recovery for airborne infectious isolation rooms.
  - Refer to section 6.8.2 exception for cases where Energy Recovery can be applied.

## Operation and Scheduling Guideline

- **Isolation Mode (Dedicated 100 % OA systems)**
  - Cooling, Heating, Humidification, Dehumidification, Ventilation – run 2 hours before and after occupancy
  - Exhaust fans – run when ventilation is on
- **Normal Mode (Supplementary HVAC systems)**
  - Cooling, Heating, Ventilation - per normal school schedule(occupied/unoccupied)
  - Exhaust fans - per normal school schedule (occupied/unoccupied), might be **OFF** during unoccupied hours



# Filtration Upgrades



## Introduction

The focus of this section is to provide instructions for educational facility managers to increase their filtration efficiency in existing air systems on a temporary basis during the pandemic. The presentation focuses on filtration basics for a facility manager, an information gathering phase, a data analytics and review phase and lastly a series of implementation and considerations an educational facility manager may address. Refer to the section on [Filtration/Disinfection under the COVID-19](#).

This guidance has been formulated to help designers and facility managers to retrofit and plan for the improvement of indoor air quality and to slow the transmission of virus via the HVAC systems. The underlying effort of the designer should be to increase outside air to the spaces, treat return air and or supply air to spaces via mechanical filtration or treating the air and maintain indoor comfort as defined by temperature and relative humidity.

The guidance should be applied to each unique climate zone, unique school building and HVAC system. All retrofits and modifications must not contradict [ASHRAE 62.1 guidelines](#) and must continue to meet code. The designer needs to work closely with the local school system to work in conjunctions with new operational protocols and school operations.





# Filtration Basics



## Key Terminology for Filtration

- **Arrestance** – A measure of the ability of an air filtration device to remove synthetic dust from the air. The arrestance describes how well an air filter removes larger particles - such as dirt, lint, hair and dust.
- **Atmospheric Dust Spot Efficiency** - The ability of a filter to remove atmospheric dust from the air and designated as a percentage.
- **MERV Rating** - Minimum Efficiency Reporting Values, or MERVs, report a filter's ability to capture particles between 0.3 and 10 microns ( $\mu\text{m}$ ).
- **Particle Size Range** – This is the composite particle size efficiency percentage within a range of particle size. The three ranges used in Std 52.2 are E1 - (0.3-1.0  $\mu\text{m}$ ), E2 - (1.0-3.0  $\mu\text{m}$ ), and E3 – (3.0-10.0  $\mu\text{m}$ ).

## Mechanical Air Filters

- Consist of media with porous structures of fibers or stretched membrane material to remove particles from airstreams. Filters range in size but the typical depths of filters are 1", 2", 4" and 12-15".
- Some filters have a static electrical charge applied to the media to increase particle removal.
- The fraction of particles removed from air passing through a filter is termed "filter efficiency" and is provided by the Minimum Efficiency Reporting Value (MERV) under standard conditions.
  - MERV ranges from 1 to 16; higher MERV = higher efficiency
  - MERV  $\geq 13$  (or ISO equivalent) are efficient at capturing airborne viruses
- Generally, particles with an aerodynamic diameter around 0.3  $\mu\text{m}$  are most penetrating; efficiency increases above and below this particle size.
- Overall effectiveness of reducing particle concentrations depends on several factors:
  - Filter efficiency
  - Airflow rate through the filter
  - Size of the particles
  - Location of the filter in the HVAC system or room air cleaner



# Filtration Basics Continued



## ASHRAE Standard 52.2-2017 -- Minimum Efficiency Reporting Value (MERV)

**Table 12-1 Minimum Efficiency Reporting Value (MERV) Parameters**

Standard 52.2 Minimum Efficiency Reporting Value (MERV)	Composite Average Particle Size Efficiency, % in Size Range, $\mu\text{m}$			
	Range 1 0.30 to 1.0	Range 2 1.0 to 3.0	Range 3 3.0 to 10.0	Average Arrestance, %
1	N/A	N/A	$E_3 < 20$	$A_{avg} < 65$
2	N/A	N/A	$E_3 < 20$	$65 \leq A_{avg}$
3	N/A	N/A	$E_3 < 20$	$70 \leq A_{avg}$
4	N/A	N/A	$E_3 < 20$	$75 \leq A_{avg}$
5	N/A	N/A	$20 \leq E_3$	N/A
6	N/A	N/A	$35 \leq E_3$	N/A
7	N/A	N/A	$50 \leq E_3$	N/A
8	N/A	$20 \leq E_2$	$70 \leq E_3$	N/A
9	N/A	$35 \leq E_2$	$75 \leq E_3$	N/A
10	N/A	$50 \leq E_2$	$80 \leq E_3$	N/A
11	$20 \leq E_1$	$65 \leq E_2$	$85 \leq E_3$	N/A
12	$35 \leq E_1$	$80 \leq E_2$	$90 \leq E_3$	N/A
13	$50 \leq E_1$	$85 \leq E_2$	$90 \leq E_3$	N/A
14	$75 \leq E_1$	$90 \leq E_2$	$95 \leq E_3$	N/A
15	$85 \leq E_1$	$90 \leq E_2$	$95 \leq E_3$	N/A
16	$95 \leq E_1$	$95 \leq E_2$	$95 \leq E_3$	N/A

# Filtration Target Level



Target Level for Filtration for Schools is **MERV 13 or higher.**

This minimum target will on average remove a minimum of 75% of particle size of 0.3-1.0  $\mu\text{m}$ .

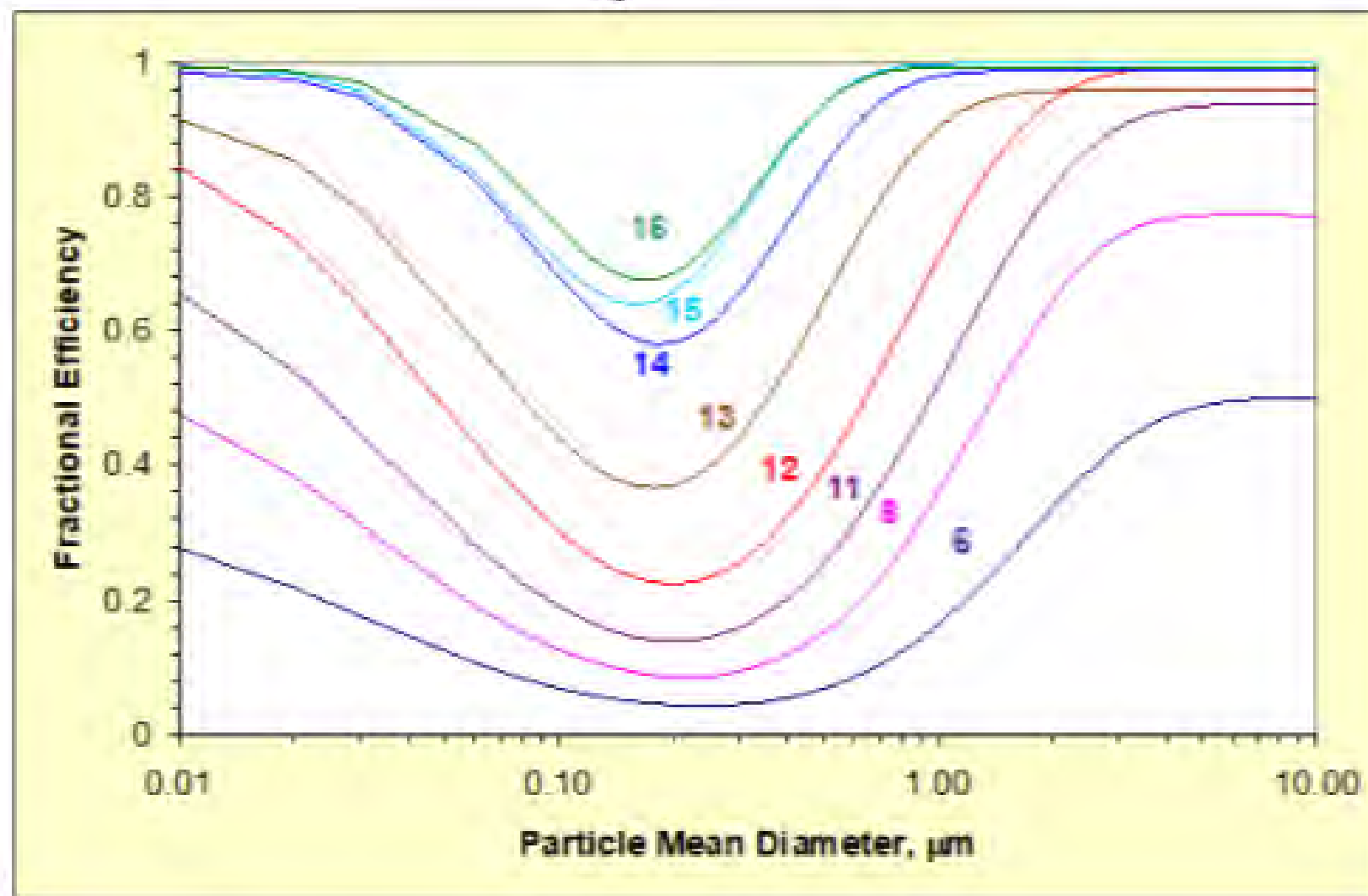

# Information Gathering Stage



## Data Collection Stage – Can be done by any staff

- Determine if the Building was LEED or CHPS Certified.
- Determine the current size, depth and quantity of filters in equipment. Make a list by piece of equipment.
- Determine if there are one or two filter banks.
- Document MERV rating of existing filters installed. May need to review previous filter orders.
- Determine the area of filter banks. This can also be determined by quantity of filters broken down by size of filter.
- Collect Original Design Drawings if available.
- Gather equipment shop drawings or Operation and Maintenance Manuals.
- Record the Model or Serial number of the air handling equipment.
- Determine the type of motor that is used in the equipment.
- Determine if the equipment served from a Variable Frequency Drive.

## Record all Data Collected





# Data Analysis & Review



## The following are steps for Data Analysis:

- If the project is a LEED or CHPS project then the filters should already be designed for MERV 13. If MERV 13 is not in place, change filters to MERV 13.
- If the existing filters and filter bank are 2" or thicker install a MERV 13 Filter. Determine if a 1" rack can be refitted with a larger rack.
- If filter racks can accept a minimum MERV 13 filter but were not part of the original design, the following analysis can be completed by internal staff or a consulting engineer:
  - Provide Information previously gathered in the Gathering Stage to individual completing additional analysis.
  - Calculate the velocity of the existing filter bank to determine existing filter pressure drop when clean.
  - Typical Velocity is between 300-500 fpm.
  - Determine the initial and final pressure drop for the filters in the original system design.
  - Calculate the increase in filter pressure drop after installing the new MERV 13 filters. Remember the final pressure drop of any filter is an operational choice.
  - Review the original design and equipment shop drawings to determine available External Static Pressure for equipment.
  - Determine the effect of additional external static pressure on the fan.



# Data Analysis & Review Continued



## Motors and Fan Curves

- Determine if the fan speed can be increased to compensate for the additional pressure drop while maintaining the required airflow.
- Determine if the speed increase exceeds the fan maximum tip speed.
- Determine if the speed increase exceeds the maximum motor power.
- Fan airflow is reduced with increase in filter restriction. This may lead to DX low suction pressures which causes faults in cooling or DX high pressure trips in heating with HP's. Electric heat elements must have sufficient airflow to operate.
- A constant cfm ECM fan will be noisier with restriction. Could increase noise in space and have a negative impact to the acoustics of the space.
- Be aware of fan surge under increased static pressure and low flow rate.

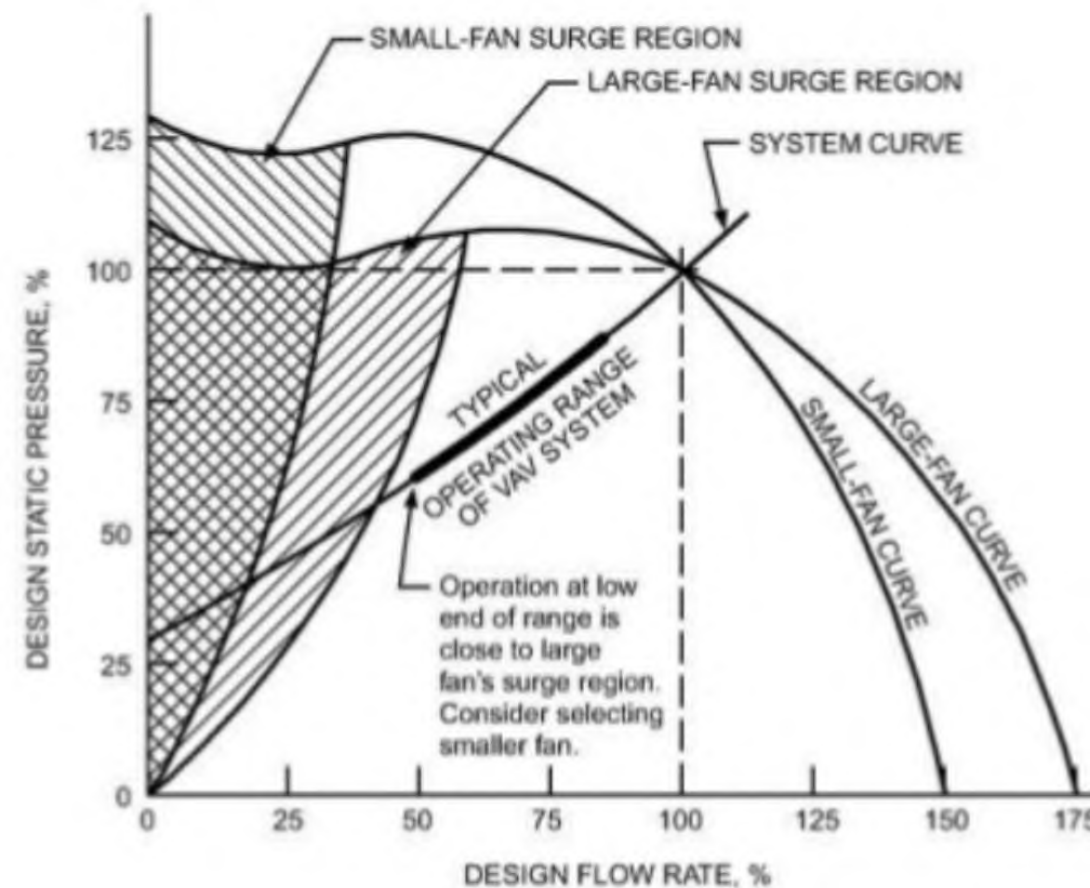

# Data Analysis & Review Continued



Fan laws are relatively straightforward:

Q = FLOW

P = PRESSURE

PWR = HORSEPOWER

RPM = FAN SPEED

$$Q_2 = Q_1 \frac{RPM_2}{RPM_1}$$

$$P_2 = P_1 \left( \frac{RPM_2}{RPM_1} \right)^2$$

$$PWR_2 = PWR_1 \left( \frac{RPM_2}{RPM_1} \right)^3$$

## Fan performance

Table 8: Standard PSC static motor

Unit Size	Speed	Factory Wired	Nominal cfm	External Static Pressure (in. w.c.)													
				0.10	0.15	0.20	0.25	0.30	0.35	0.40	0.45	0.50	0.55	0.60	0.65	0.70	0.75
007	High	Yes	300	410	400	390	380	360	350	330	320	310	290	270	250		
009	High	Yes	300	410	400	390	380	360	350	330	320	310	290	270	250		

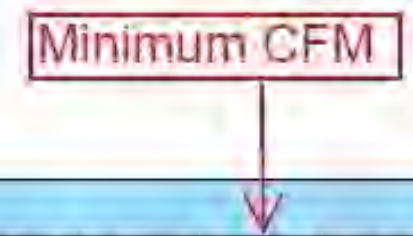



# Implementation & Considerations



## What are the next steps?

- If MERV 13 filters are installed in the existing equipment then order additional filters for future filter changes.
- Filter Rack Maintenance and Replacement:
  - If filter rack is damaged then repair rack,
  - Ensure filter rack is sealed to prevent bypass of unfiltered air,
  - Review seal installation procedures with maintenance and operations staff,
  - Replace and Upgrade Rack if possible, to accept a filter with a higher MERV rating.
- Consider changing out motor to increase static pressure available, but this may require significant electrical modifications.
- Adjust the Variable Frequency Drives to address increase in static pressure for filters.

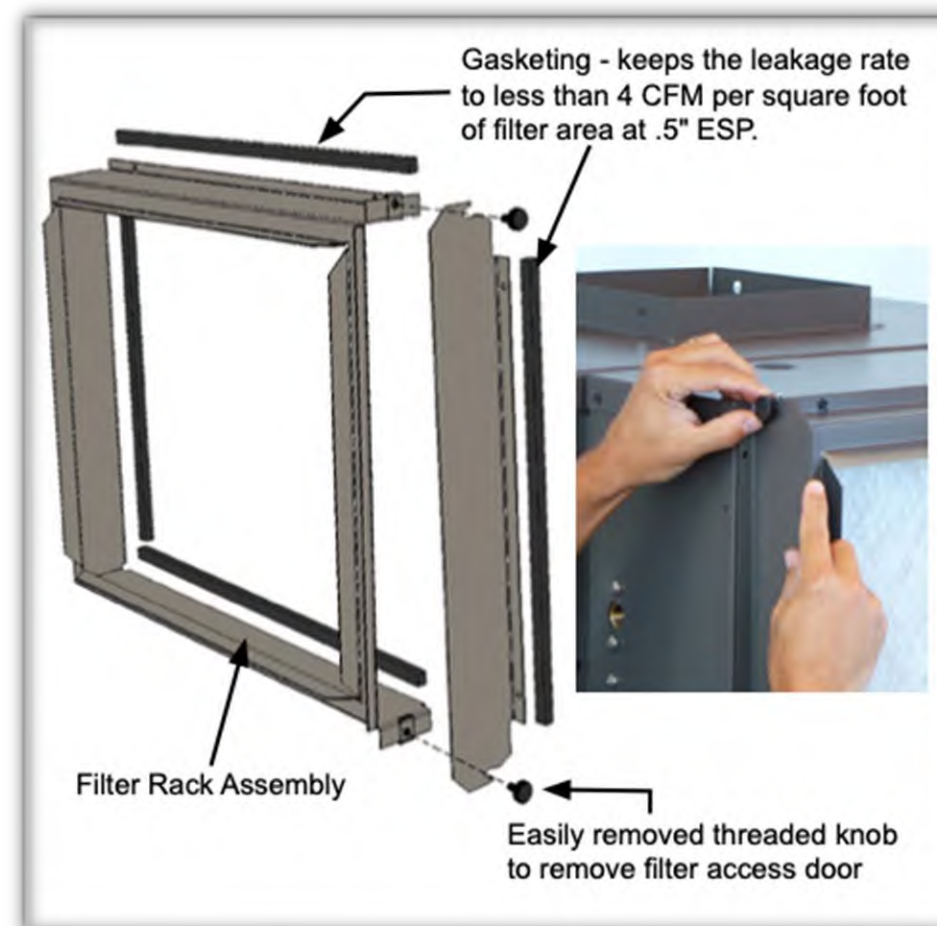



# Implementation & Considerations Continued



## If MERV 13 Filters cannot be installed consider the following:

- Increase the filtration in the unit to the maximum available
- Provide a recirculation fan filtration unit and duct into the return of units
- Provide a HEPA filtration unit which re-circulates air within the space
- Consider Air Ionization system or static charge on filters
- Consider UV treatment but review location to avoid impacts of liners and other internal components
- Refer to [ASHRAE Filtration and Disinfection system](#) section for additional information
- Consider alternate filter locations in return duct or grille but consider static pressure drop implications and relationship with outside air dampers

## Additional Considerations:

- Install a pressure gauge on units to assist in determining filter change frequency
- Document motor amperages before and after filter changes, alarm points in BAS may need to be updated
- Filter change frequency may increase due to seasonal and atmospheric considerations at different sites (such as Pollen Season)
- There will be an increase in fan energy used to overcome additional pressure drop from filters
- With an increase pressure drop for filtration there will be less airflow to heat and cool the spaces during peak design days
- Additional supplementary heaters or cooling devices may be required



# Implementation & Considerations Continued



## HVAC System Maintenance and Filter Replacement during the COVID-19 Pandemic:

- For HVAC systems suspected to be contaminated with SARS-CoV-2, it is not necessary to suspend HVAC system maintenance, including filter changes but additional safety precautions are warranted
- The risks associated with handling filters contaminated with coronaviruses in ventilation systems under field-use conditions have not been evaluated
- Workers performing maintenance and/or replacing filters on any ventilation system with the potential for viral contamination should wear appropriate personal protective equipment (PPE)
- When feasible, filters can be disinfected with a 10% bleach solution or another appropriate disinfectant, approved for use against SARS-CoV-2, before removal. Filters (disinfected or not) can be bagged and disposed of in regular trash, or applicable local health and safety standards
- When maintenance tasks are completed, maintenance personnel should immediately wash their hands with soap and water or use an alcohol-based hand sanitizer.



# Operation of Occupied Facilities



1. Measure/Trend all information possible, including temperature (dry bulb), relative humidity, carbon dioxide concentration, zone population, etc. - may be done with central Building Automation System (BAS) if available - mobile/handheld devices may be used if central monitoring not available.
2. Follow up on temperature control, humidity control or elevated carbon dioxide concentration issues observed to address cause(s).
3. Document any unusual observations other than those that can be recorded by control systems.
4. Share pertinent information between all appropriate groups: Maintenance, Energy, Environmental Health & Safety, Building Managers, Administration, etc.
5. Create reporting methodology for tracking and reporting of critical infections. Develop policies for use of drinking fountains/water coolers.
6. Develop policies for lockers or storage spaces.
7. Develop maintenance policies for new/added equipment such as local air cleaners, humidifiers, additional filtration in mechanical equipment, etc.

# Controlling Infection Outbreaks in School Facilities



1. Identify symptoms in Student.
2. Provide PPE and remove suspect individual – relocate to nursing or isolation space.
3. **a.** A K-12 Facility should develop a policy to isolate the student near the [nurse's office in a room described in this guidance](#), inform parents and release symptomatic student according to that policy.  
**b.** Higher education facilities should isolate that student at the [Student Health Facility in a room described in this guidance](#) until that student can either safely travel home or be transported to a medical facility, if necessary.
4. Notify appropriate individuals (either parents or students) about possible contact.
5. Develop protocol to handle quarantine of other individuals who may have been exposed, wash/sanitize belongings and impacted spaces, look at potential for spread to adjacent spaces or other building areas through mechanical systems or other means.
6. Develop protocol to handle air cleaning for space prior to re-occupying (ozone, local HEPA filtration, combination unit with filtration and UV, similar technologies).
7. Report/track incident through defined policies.



# Higher Education Facilities





# Student Health Facilities



Screen patients entering clinic in waiting area

- Establish physical barrier in waiting room for screening
- Require face mask and hand sanitation from a sanitizer dispenser
- Increase ventilation rate six ACH clean air
- Create at least one isolation exam room in waiting area (can be temporary)
- Add non-woven fabrics for seating
- Use laminate or solid surface casework to improve cleaning
- Remove carpet for flooring



# Student Health Facilities



## Temporary Isolation Rooms during Pandemic in addition to waiting room

- Isolation rooms – Follow [ANSI/ASHRAE/ASHE Standard 170](#)
  - Negative Pressure to 0.01 inches of water
  - Twelve air changes (HEPA recirculation allowed)
  - All air exhausted to outdoors (exhaust grill above exam table)
- Provide minimum two isolation rooms (conduct risk assessment)
- Dedicated HVAC capable of 100% OA
- Anteroom/Protective Equipment Room
- Normal non-isolation nurses office can become iso-room
- Include Biohazard waste storage in anteroom and iso-room for PPE



# Student Health Facilities



## Temporary Isolation Rooms during Pandemic in addition to waiting room: Design Concepts

See layout suggestion here, can be modified as needed

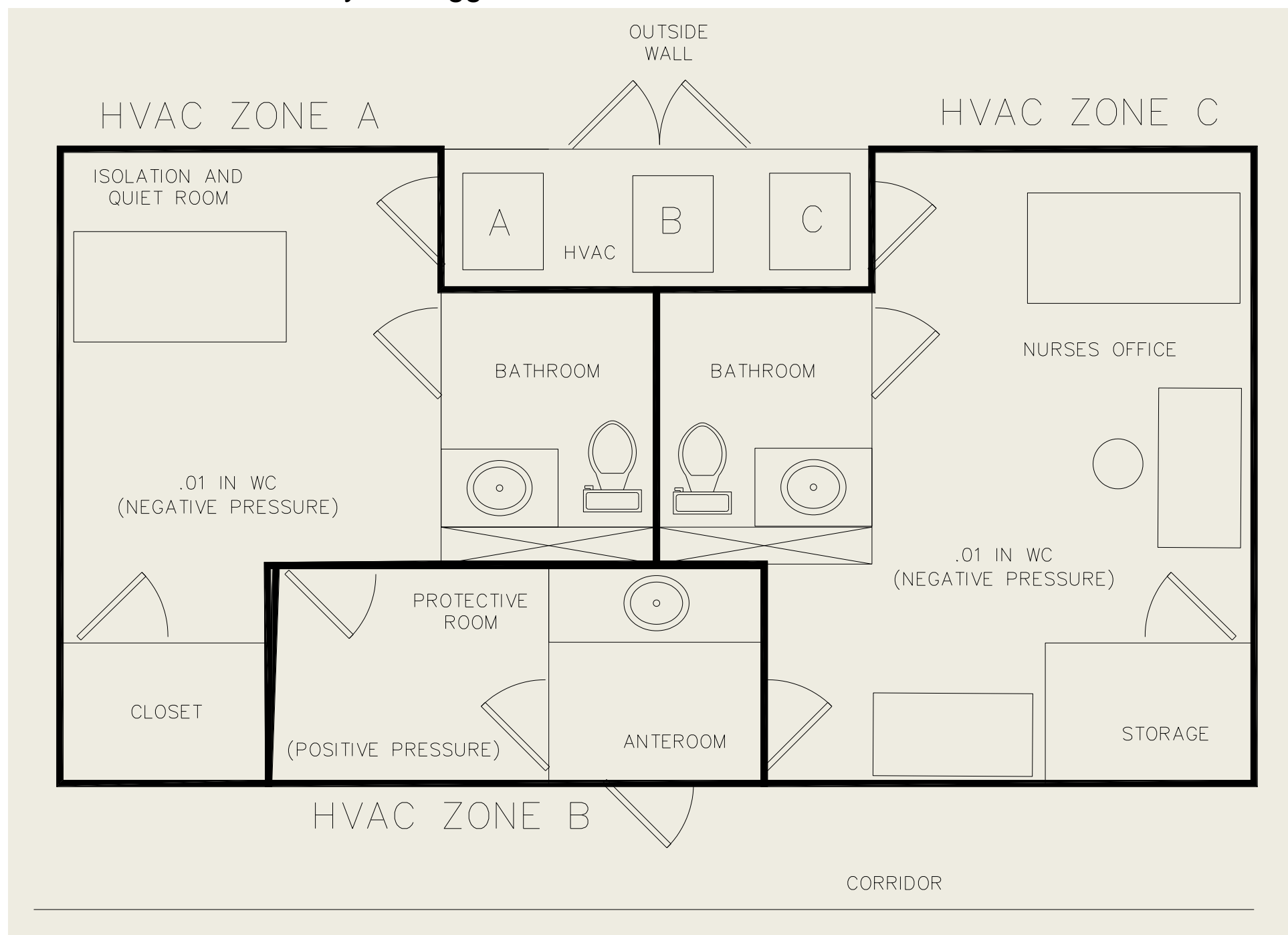

# Laboratories (NFPA 45 type lab)



## Before Student Occupation during Pandemic

- Verify space has one-pass air or maximum OA capable for lab operating requirements
- Screen occupants upon entry
- Require face mask and hand sanitation
- Modify workstations to comply with social distancing
- Install hand sanitizer dispenser in entryway
- Verify all fume hoods and bio-safety cabinets are up-to-date on certification
- Conduct smoke tests in all spaces to verify airflow patterns





# Athletics Facilities

- ❑ Move activities outdoors if possible
- ❑ Limit occupancy to maintain social distancing guidelines and avoid unnecessary occupants
  - ❑ Increase outdoor air ventilation rates
  - ❑ Increase rates as high as possible
- ❑ Maintain minimal comfort conditions
- ❑ Avoid use of locker rooms but if necessary Increase airflow in locker rooms and keep negative
- ❑ Verify all locker room exhaust flows exceed [ANSI/ASHRAE Standard 62.1](#)





# Residence Halls



- ❑ Consider reducing occupancy in rooms, suites and common areas
- ❑ Consider HEPA/UVC portables
- ❑ Install hand sanitizer dispenser in common areas
- ❑ Use non-woven fabrics for seating
- ❑ Use laminate or solid surface casework
- ❑ Cover or remove carpet for flooring
- ❑ Verify exhaust air flow in all restrooms and laundries
  - ❑ Minimum 1.0 cfm/sf
- ❑ Verify all outdoor air flows are well distributed ( $> 0.16$  cfm/sf)
- ❑ Replace filters with MERV 13 or higher where ever possible
- ❑ Refer to [the Filtration and Disinfection Guidance](#)
- ❑ This guidance assumes no COVID-19 cases are housed





# Large Assemblies, Lecture, Theater



- Limit occupancy to maintain social distancing guidelines
- Increase outdoor air ventilation rates
- Replace all filters with MERV 13 or higher
- Verify exhaust airflows in all toilets and locker rooms
  - Minimum 1.0 cfm/sf
- Verify exhaust airflows from all concession stands
  - Minimum 0.7 cfm/sf
- Provide additional outdoor air and/or HEPA filter units in rehearsal rooms and green rooms
- Disable demand control ventilation control

**TAB 5B**





# ASHRAE EPIDEMIC TASK FORCE

**BUILDING READINESS** | Updated 8-19-2020



## **General Information**

- [Building Readiness Intent](#)
- [Building Readiness Team](#)
- [Building Readiness Plan](#)

## **Epidemic Conditions in Place (ECiP)**

- [Systems Evaluation](#)
- [Building Automation Systems \(BAS\)](#)
- [Increased Ventilation](#)
- [Increased Ventilation Control](#)
- [Building and Space Pressure](#)
- [Pre- and Post-Flushing Strategy](#)
- [Upgrading and Improving Filtration](#)
- [Energy Savings Considerations](#)
- [Exhaust Air Re-entrainment](#)
- [Energy Recovery Ventilation Systems Operation Considerations](#)
- [UVGI Systems](#)
- [Domestic Water Systems](#)
- [Maintenance Checks](#)
- [Shutdown a Building Temporarily-FAQ](#)
- [System Manual](#)
- [Reopening During Epidemic Conditions in Place](#)

## **Post-Epidemic Conditions in Place (P-ECiP)**

- [P-ECiP: Prior to Occupying](#)
- [P-ECiP: Operational Considerations once Occupied](#)
- [P-ECiP: Ventilation](#)
- [P-ECiP: Filtration](#)
- [P-ECiP: Building Maintenance Program](#)
- [P-ECiP: Systems Manual](#)

## **Additional Information**

- [Acknowledgements](#)
- [References](#)
- [Disclaimer](#)

*Information in this document is provided as a service to the public. While every effort is made to provide accurate and reliable information, this is advisory, is provided for informational purposes only, and may represent only one person's view. They are not intended and should not be relied upon as official statements of ASHRAE.*



# General Information



## Building Readiness Intent

The following Building Readiness information is meant to provide practical information and checklists for how your building should be operating and how to practically check its operation. Actual conditions at any specific building will vary, and the adjustments that should be made will depend on many factors such as local climate, complexity of systems involved and the use, occupancy and activities that occur in and around your building.

Building Readiness modes of operation for the building should include the following:

- Epidemic Operating Conditions in Place (ECiP)
  - Occupied- at pre-epidemic capacity
  - Occupied- at reduced capacity
  - Unoccupied temporarily, and
  - Operation during building closure for indefinite periods
- Post-Epidemic Conditions in Place (P-ECiP)
  - Prior to Occupying
  - Operational Considerations once Occupied

# General Information

## Building Readiness Intent Continued

This document will provide some of the practical guidance on operating your building systems in these different modes. The suggested mode of operation during the Epidemic periods are detailed in the Buildings Guidance on the [ASHRAE Covid-19 Website](#).

- Healthcare
- Residential
- Commercial
- Schools
- Transportation

In addition, this document will cover specific recommendations from the Building Guidelines such as:

- Increased ventilation
- Increased filtration
- Energy recovery ventilation systems operation considerations
- Building exhaust air re-entrainment

This document assumes that the Owner and Facility Operators have completed their Epidemic Preparedness Plan and are ready to shut down, operate, and re-open their building. This can be done in either mode, ECiP or P-ECiP.

The following guide is to provide practical guidance for the Mechanical Systems for those scenarios.

Keep in mind, that for the P-ECiP mode, there are really two phases to consider; Prior to Occupying, and Operational Considerations once Occupied.



# General Information

## Building Readiness Team

The Building Readiness Team could include professionals and licensed and certified individuals and companies that can perform the analysis, testing, design, construction, control programming, balancing, commissioning, maintenance and operation services required to make the adjustments and achieve the performance included in these recommendations. The following are the typical service providers that may be required:

- **Commissioning Provider (CxP)** – engage a CxP that has a recognized certification from ASHRAE (BCxP), ACG (CxA), BCA (CCP), NEBB (BSC and RCx), or others. They should also have completed several Retro-Commissioning or New Building Commissioning projects in the building type in question.
- **Test and Balance Company (TAB)** – engage a TAB that has recognized certification from Associated Air Balance Council (AABC), National Environmental Balancing Bureau (NEBB) and Testing Adjusting and Balancing Bureau (TABB) or another certifying body. The TAB agent or service provider should have experience with the building type and systems being evaluated. These certifying bodies require a TAB company operator to have been trained and certified and requires the use of calibrated instruments.
- **Building Automation Systems (BAS) Company** – the Owner should engage the company currently providing service and support for the control system(s) that are installed in the building. If a new service provider is required, finding a local company that has experience working with and operating the building’s existing control systems and preferably certified by the manufacturer to provide services for their equipment.
- **Contractors** – the Owner should engage, if necessary, the appropriate contractors to install or repair equipment or systems identified by the CxP, TAB, or BAS providers. This could include the following:
  - General Contractors (GC)
  - Mechanical Contractor (MC)
  - Electrical Contractor (EC)
  - Specialty contractors for fire alarm and smoke control systems and interfaces.
- **Architect and/or Engineer (AE)** – the Owner should engage a design team for any issues that might require permit drawings. It is preferred that the original Engineer or Architect of Record that was involved with the original construction or the latest renovation or addition to the facility be engaged if possible. Those professionals should be most familiar with the building’s current operation.
- **Owner’s Facility Staff** – the Owner should make sure that their facility staff are involved in the process. This allows for the information transfer on how systems might be altered to operate.



# General Information



## Building Readiness Plan

This is a document that should be created to document the mitigation strategies that the facility is going to utilize, whether temporary or permanent modifications, for the facility operators and occupants to understand the plan.

This should include the non-HVAC strategies as well as the HVAC mitigation strategies that are discussed in this document.

Non-HVAC strategies could include, but not be limited to, the following items:

- Building Occupancy Levels Allowed
- Face mask requirement or recommendation
- Social distancing between desks, breakrooms, conference rooms, elevator, etc.
- Directional flow for office space
- Personal hygiene
- Cleaning requirements

HVAC strategies could include, but not limited to, the following items:

- Increased Ventilation
- Improved Filtration
- Air cleaning devices (such as UVGI and other newer technologies)

It is crucial to note, that each HVAC system needs to be analyzed for the appropriate engineering controls to utilize to improve its potential to reduce virus transmission in the building.



# Epidemic Conditions in Place



## Systems Evaluation:

The Owner should consider evaluating their building systems to check that it is operating in proper order (per design conditions or current operational strategies), is capable of being modified to align with HVAC mitigation strategies, and to identify deficiencies that should be repaired. This could be viewed as tactical commissioning of the systems to determine risk areas for the building operating in epidemic conditions.

### Systems evaluation should include the following steps:

1. Gather and review building and systems documentation, including but not limited to:
  - a. Most recent design documents, specifically the HVAC and Plumbing Water systems construction documents
  - b. Record documents (as-built, marked up drawings and specifications received from the Contractor at the conclusion of construction)
  - c. Original, approved equipment and system submittal documents
  - d. Systems manuals or turnover package
  - e. Controls and Building Automation System (BAS) drawings and sequences of operation and initial system parameters
  - f. Equipment control wiring diagrams and troubleshooting guidelines
  - g. Service contracts and maintenance logs
  - h. BAS Trend reports and alerts and notifications reports
  - i. Most recent Testing, Adjusting and Balancing (TAB) reports
  - j. Most recent Commissioning Reports (if available)

# Epidemic Conditions in Place



## Systems Evaluation Continued:

2. **Inspect equipment, systems and controls to determine where existing problems may exist.**  
**Start with components, then move to systems, finally move to the BAS and integrated, whole building operations.**

### For example:

#### a. Components

- i. Boilers
- ii. Chillers
- iii. Air Handling Units
- iv. Control Dampers
- v. Control Valves
- vi. Control Sensors
- vii. Airflow Measuring Stations (AFMS)
- viii. Fan Coil Units
- ix. Grilles, registers and diffusers
- x. Variable speed drives
- xi. Variable Air Volume terminal units,
- xii. Water-to-water heat exchangers
- xiii. Water-to-refrigerant heat exchangers
- xiv. Water to air heat exchangers
- xv. Steam-to-water heat exchangers

#### b. Systems

- i. Chilled water systems
- ii. Hot water systems
- iii. Condenser water systems
- iv. Air handling systems (Air handling equipment and air distribution networks: supply ducts, return ducts, exhaust ducts)
- v. Steam distribution systems
- vi. Refrigerant systems

# Epidemic Conditions in Place



## Systems Evaluation Continued:

### c. Building Automation Systems (BAS) and Integrated Systems

- i. Graphic user interfaces
- ii. Set Points (Temperature, Humidity, Airflow, CO2, etc)
- iii. Schedules (Occupied and Unoccupied)
- iv. Trend reports
- v. Alarm, alert and notification logs
- vi. Remote access capabilities
- vii. Life safety system interfaces and interlocks
- viii. Access control interfaces
- ix. Smoke control system interfaces
- x. Lighting control interfaces
- xi. Electronic security system interfaces



# Epidemic Conditions in Place



## Systems Evaluation Continued:

3. The investigators should be considering the HVAC mitigation strategies to reduce the potential bio-burden in the building that could be implemented on the systems.
4. When checking calibration, use the guidance in [ASHRAE Guideline 11-2018 -Field Testing of HVAC Control Components](#).
5. Prepare a deficiency log and issue work orders to in-house maintenance personnel and purchase orders to qualified service providers to correct any critical issue identified in steps 1 and 2 that would prevent the system(s) from functioning in accordance with the systems' original design intent or the building's current use, occupancy and activity.
6. Prepare a report that identifies the HVAC mitigation strategies for the systems. This should include a brief work order description for the in-house maintenance personnel and qualified service providers. This should detail modifications or additions to components, systems and controls necessary so that the recommendations included in this document may be implemented.

# Epidemic Conditions in Place



## Building Automation Systems (BAS)

### Evaluate your BAS:

You need to understand the type of BAS you have in your building. HVAC controls range from simple single zone thermostats controlling a single HVAC unit's heating and cooling modes of operation, to complex BAS that integrate the controls from large building owners and owners with multiple large buildings in their portfolios, such as school districts, university campuses and large government installations and everything thing in between.

In addition, there are legacy HVAC systems and BAS that still use electric and pneumatic controls and time clocks that do not have modern, digital communications interfaces and therefore, do not allow building operators any insight into how their buildings are performing without being physically in the building or at the piece of HVAC equipment.

# Epidemic Conditions in Place



## Building Automation Systems (BAS) Continued Remote Access:

If the building is equipped with a Building Automation System (BAS), it should have an existing method for remote access.

If the BAS does not have a method for remote access, the owner should coordinate with buildings IT provider and BAS provider for secure remote access for the required users.

- Cybersecurity must be put at the forefront of this endeavor as to not open the BAS and other building networks to unauthorized access.
- If the BAS is not on its own Virtual Local Area Network (VLAN) consider segregating the building systems (BAS, Fire Alarm, Card Access, Cameras, etc.) into a VLAN to limit remote exposure to the buildings internal networks.
- Consider two step authentication as mandatory for remote access.
- Care should be taken in granting editing access to the BAS to knowledgeable, trained operators only.
- Set up user logging such that a virtual log of all changes are documented.

These remote systems range from the simple to complex communication capabilities.

- The simple could be dial up modems transmitting alerts and notifications to cell phones and/or email addresses.
- The more complex is a BAS system that is connected to local area networks that can be accessed via VPN connections.

Depending on that connection, there are variations to the amount of data access which can range from limited data to a fully web based, graphic user interfaces connected to a host of mobile devices such as smartphones, tablets and stationary PC workstations.

# Epidemic Conditions in Place



## Building Automation Systems (BAS) Continued

### Prior to making any changes:

- Perform a full backup of all BAS software, databases, programs, graphics, trends, schedules, etc. and store off site either physically or in the cloud.
- Consider printing them physically or to a pdf so that values can easily be returned when the epidemic is over.
- Inspect or replace any batteries in building controllers such that databases are not lost during any extended power interruptions.
- If your building is not on a scheduled BAS inspection (either by third parties or self-performed) consider performing a preventative maintenance inspection of all systems to ensure proper operation prior to any changes being made. Consider retaining the services of an independent 3rd party commissioning service provider (CxP) to help you review the scope of work for any control system modifications and who can verify the systems are functioning as intended.
- Review the access requirements with all parties that the owner wants to have remote access during the unoccupied or modified mode of operation period.
- Determine the level of access and permissions each person with access should have, such as full access to make changes in set points, schedules and system programming, schedule overrides only, alerts and notification access only and view only access.
- Confirm with company IT departments what requirements may be in place to qualify, screen and approve people for remote access to control systems and company IT networks.
- Set each person up as a unique user having unique usernames and password and permission levels so that access and changes to the system can be monitored and documented.
- Have a trained and experienced operator go over the existing systems remote access features of the system and its interface with anyone who will be given remote access to the system.
- Review all alerts, notifications, event logs and system and control point trend reports prior to making any modifications and download those reports to create a baseline for comparing the effects of any changes that may be made in the future.



# Epidemic Conditions in Place



## Building Automation Systems (BAS) Continued

### Prior to making any changes:

- If possible, walk the facility or facilities being controlled and managed by the BAS to become familiar with the location, size and scale of the control network.
- As minimum, review system graphics for all system types and buildings to become familiar with the system(s).
- Make note of any communication issues with components, sensors, controllers, buildings, etc. and develop a list of repairs that may need to be made before the system is placed in extended shut down, unoccupied or partial occupancy modes of operation.
- Review system graphics or text-based reports to determine if temperatures, humidity, CO2, airflows (supply, return, outside air, exhaust), damper positions, control valve positions, motor speeds and status are returning or reporting reasonable values.
- Use test instruments to verify any questionable information and to spot check a representative quantity of points. Start with verifying critical sensors, such as CO2 or airflow measuring stations.
- Collaborate with the building owner, building users and building operators and create a plan for modifications to sequences, set points and system operations.
- Note who was in attendance, what was discussed, and any decisions made and implemented.
- Obtain buy-in and approval from key stakeholders before making any changes.
- Repairs to systems involved in this response should be considered mandatory as any new sequences may not be able to be implemented via the BAS.

# Epidemic Conditions in Place



## Building Automation Systems (BAS) Continued

### Making changes to accommodate epidemic responses:

- After determining what sequence of operation changes are appropriate, make small changes to the system at a time and monitor for a few days or through some varying weather conditions to make sure the system and building(s) is responding to the changes as expected.
  - Have the CxP or Control Contractor verify and document the effect of the changes through key trend reports and physical measurements or standalone data loggers.
- Keep good records and document all meetings, agreed to repairs, maintenance and changes with written communication.
- The team should consider making the changes to include an automated response such that you may return to the original sequences (or pre and post pandemic sequences) at the push of “virtual” button.
  - Care should be taken to limit access to the initiation of these automated sequences as they may have a large energy and comfort impact on your facility.
- Existing alarm parameters may need to be adjusted during these new sequences as the original “normal” conditions may not be able to be met.
- Ensure that this team follows the guidance for the facilities Systems Manual later in this document.

# Epidemic Conditions in Place



## Increased Ventilation

The Building Guidance clearly encourages building operators to increase their systems outdoor air ventilation to reduce the recirculation air back to the space. The guidance indicates that this must be done as much as the system and or space conditions will allow. It is very important that these overall building systems are evaluated by a qualified TAB firm, Cx provider or design professional to ensure that the modifications for pandemic safety do not create additional issues.

One major concern is the ability to maintain space conditions. Hot and humid climates could struggle to keep the space below acceptable temperature and relative humidity for comfort. Cold climates could struggle to keep the space above acceptable space temperature and relative humidity for comfort. It is important to note that research indicates that maintaining the space relative humidity between 40% and 60% decreases the bio-burden of infectious particles in the space and decreases the infectivity of many viruses in the air. The team should consider adjusting the space comfort setpoints to increase the system's ability to use more outside air.

The ability for a coil to provide additional capacity was evaluated using a typical cooling coil at various percent of outside air. This evaluation shows the additional required cooling capacity and gpm required[1] if the same exact coil experiences the different entering air conditions while achieving constant leaving air conditions. The following shows the impact of increasing the percent of outside air:

Percent OA	EAT DB / WB	CHW GPM	Coil Pressure Drop (Ft H2O)	Total Capacity (MBH)	Sensible Capacity (MBH)
20	78.43 / 69.31	88.64	7.06	541.29	292.45
30	79.64 / 70.80	95.82	8.14	596.98	306.33
40	80.84 / 72.64	107.15	9.99	671.74	320.33
50	82.04 / 73.64	113.49	11.10	712.95	333.99
60	83.24 / 75.00	121.01	12.49	768.22	347.89
70	84.44 / 76.30	131.79	14.61	826.98	361.82
80	85.63 / 77.57	139.60	16.24	881.63	375.69
90	86.81 / 78.80	151.96	18.99	941.36	389.49

*The unit was selected to be 10,000 cfm with a constant 44°F chilled water supply with a 12°F chilled water rise to make a consistent coil leaving air temperature of 52°F dry-bulb and 51.5°F wet-bulb. This assumes a return air condition of 76°F and 60% RH from the space. The outside conditions are the Orlando WB with MCDB which is 88 °F dry-bulb and 80 °F wet-bulb. The coil was locked in at an 8-row coil with 126 fins per foot that is 20.45 square feet of coil face area.*



# Epidemic Conditions in Place



## Increased Ventilation Continued:

- Another way to potentially increase the quantity of outside air is to clean your cooling coil to recapture lost heat transfer from fouling.
  - Studies indicate that dirty coils reduce the capability for heat transfer.
  - Please follow the appropriate maintenance for coils.

# Epidemic Conditions in Place



## Increased Ventilation Control:

The assessment team determining how much more a coil can handle can see that increasing from 20% outside air to 90% outside air doubles the required chilled water, triples the coil pressure drop and requires just over twice the amount of cooling source from the chiller plant. The capacity of your plant needs to be evaluated.

There are other options to increase the outside air in an AHU as much as the building automation system (BAS) will allow based on space conditions. There are two different approaches to modify a system to optimize the outside air without ignoring space comfort in hot and humid climates that is a twist on the dynamic supply air temperature reset strategy. This is assuming a typical variable air volume AHU serving multiple VAV boxes or as a single zone VAV unit. The outside air damper and return dampers could be linked or separate, but they work in opposite directions in any option presented.

### Option 1: Increased OA based on Cooling Coil

If the cooling coil control valve is less than 90% AND the discharge air temperature (or space temperatures) are satisfied, OPEN the OAD [CLOSE the RAD] 3% every 15 minutes.

If the cooling coil control valve is greater than 90% OR the discharge air temperature (or space temperatures) is exceeded by 1-degree F, CLOSE the OAD [OPEN the RAD] 6% every 5 minutes.

### Option 2: Increased OA based on Space Conditions

This option assumes that a coil leaving air temperature controls the CHW valve to maintain a constant setpoint.

If the space temperatures are satisfied and the relative humidity is less than 55%, OPEN the OAD [CLOSE the RAD] 3% every 15 minutes.

If the space temperatures are exceeded by 1-degree F OR the relative humidity is greater than 60%, CLOSE the OAD [OPEN the RAD] 6% every 5 minutes.

These options require different sensors to be installed in the unit to work properly. Either sequence would allow the unit to increase the outside air ventilation as much as possible without exceeding the space comfort conditions. It is also important to note that demand controlled ventilation, static pressure reset strategies and the typical supply air temperature reset strategies should be disabled.

# Epidemic Conditions in Place



## Building and Space Pressure:

Building and space pressurization is another important consideration.

Care should be taken when increasing outside air but keeping exhaust and relief air systems as designed. New problems can be created such as:

- Doors that will not close
- Excessive noise at entrance doors and between adjacent spaces
- Access / egress issues at common hallways or egress points (in extreme conditions)
- Reverse of the intended pressure required for a space

Excessive building pressurization can also affect vertical transportation systems and areas that are intended to be negatively pressurized, such as commercial kitchens, bathrooms, process areas and custodial areas.

It is very important that these overall building systems are evaluated by a qualified TAB firm, Cx provider or design professional to ensure that the modifications for pandemic safety do not create additional issues.

# Epidemic Conditions in Place



## Pre- and Post- Flushing Strategy:

The intent is to ensure that while the building is operating, your ventilation schedule should assist in removing bioburden during, pre-, and post- occupancy of the building. Flush the building for a duration sufficient to reduce concentration of airborne infectious particles by 95%. For a well-mixed space, this would require 3 air changes of outside air (or 3 equivalent air changes including the effect of filtration and air cleaners) as detailed in the calculation methodology.

In lieu of calculating the air change rate, pre- and post-occupancy flushing periods of 2 hours (for a total of 4 hours) may be used since this should be sufficient for most systems meeting minimum ventilation standards.

So for each mode, the control would be as follows:

- Occupied: bring in the most outside air that the systems can accommodate as described above
- Pre- and Post-: The general method is to operate the systems in Occupied Mode for “x” hours prior to, and after, daily occupancy. Use the calculation to determine “x”.

# Epidemic Conditions in Place

## Flushing Air Changes Calculations for Well-Mixed Spaces

One air change =  $c / C_0 = \exp^{-1} = 0.368$

Three air changes =  $c / C_0 = \exp^{-3} = 0.050$

Therefore, three air changes result in the removal of 95% of the contaminants in the space for a well mixed system

### Assumptions:

- $V$  = Volume
- $Q_t$  = Total air flow
- $c$  = space concentration
- $C(t=0) = C_0$
- $C_{OA} = 0$
- $N$  = number of air changes
- ACH is outdoor airflow rate in air changes per hour
- $t[h]$  = hours for pre- and post-flush

Change of contaminant in space is equal to flow of contaminant in minus flow of contaminant out during a time interval  $dt$

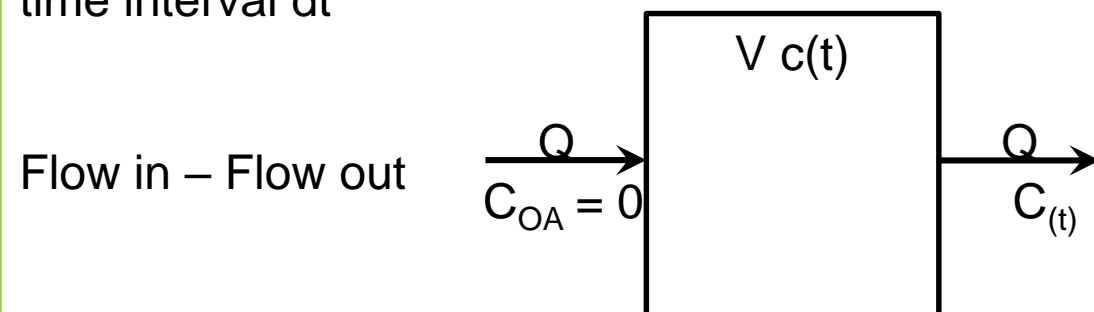

$$VdC = (QC_o - QC)dt$$

Outdoor air concentration is zero so

$$VdC = -QCdt$$

$$\frac{dC}{C} = -\frac{Q}{V}dt$$

$$\int_{C_0}^c \frac{dC}{C} = -\int_0^t \frac{Q}{V}dt$$

$$\ln(C) - \ln(C_o) = -\frac{Qt}{V}$$

$$\frac{C}{C_o} = \exp\left(-\frac{Qt}{V}\right) = \exp(-N)$$

Where  $N$  = number of air changes

Time for  $N$  air changes:

$$N = \frac{Qt}{V}$$

$$t = \frac{N}{Q/V}$$

$$t[h] = \frac{N}{ACH}$$

Where ACH is the outdoor air flow rate in air changes per hour (ACH)





# Epidemic Conditions in Place



## Upgrading & Improving Filtration:

Building owners are encouraged to improve the efficiency of the filters serving their HVAC systems within the guidance provided for most of the building types listed on the [ASHRAE COVID-19 Preparedness Resources](#) website. Mechanical filters are the most common types of filters found in HVAC systems. According to the [ASHRAE Position Document on Filtration and Air Cleaning](#), the term used to describe mechanical filter efficiency is MERV. MERV is an acronym for Minimum Efficiency Reporting Value. The MERV rating of a mechanical filter is determined by filter manufacturers in accordance with [ASHRAE Standard 52.2 - Method of Testing General Ventilation Air-Cleaning Devices for Removal Efficiency by Particle Size](#). Standard 52.2, table 12-1 lists filter MERV rating parameters for MERV 1 through MERV 16. The higher the MERV number the better the ability of a filter to remove particles from the air ranging in sizes from 0.3 micron diameter up to 10 microns in diameter at standard airflow conditions and face velocities specified in the test standard. A more detailed discussion of the various air filtration and disinfection technologies available may be found on the [ASHRAE COVID-19 Preparedness Resources main page](#) under the **Filtration/Disinfection** tab.

ASHRAE recommends that mechanical filter efficiency be at least MERV 13 and preferable MERV 14 or better to help mitigate the transmission of infectious aerosols. Many existing HVAC systems were designed and installed to operate using MERV 6 to MERV 8 filters. While MERV 13 and greater filters are better at removing particles in the 0.3 micron to 1 micron diameter size (the size of many virus particles) the higher efficiency does not come without a penalty. Higher efficiency filters require greater air pressures to drive or force air through the filter. Care must be taken when increasing the filter efficiency in an HVAC system to verify that the capacity of the HVAC system is sufficient to accommodate the better filters without adversely affecting the system's ability to maintain the owner's required indoor temperature and humidity conditions and space pressure relationships.

# Epidemic Conditions in Place



## Practical Approach to Increase MERV in an AHU:

The following are practical steps an owner can take to evaluate the maximum MERV rating and HVAC system can accommodate while maintaining acceptable system performance:

1. Consider retaining the services of a qualified design professional, a certified commissioning provider (CxP) or a certified testing, adjusting and balancing (TAB) service provider especially for larger, more complex HVAC systems or for systems serving critical buildings or spaces within buildings.
2. If available, gather the documents described above under the [System Evaluation section of this document](#). One of the most valuable documents to have on hand for analyzing filter upgrades would be the original TAB report if the building configuration, use and occupancy has not changed since the building was originally constructed. Consider having readings taken to confirm the values in the TAB report.
3. Determine the manufacturer, size and thickness and MERV rating of the existing filters. For example, 20 inches by 20 inches square, 1-inch thick, MERV 8. Obtain the filter's operating characteristics from the manufacturer or the manufacturer's website.
4. Inspect the filter frames inside the air handling equipment where the filters are installed to determine the filters fit tight within the frames and seals around the perimeter of the frame to minimize any air leakage around the filters (often called bypass air). For most filter frames, it would be wise to add silicone sealant on the upstream and downstream side of the frame as it meets with the AHU wall.
5. With the existing filters installed in the system, have the TAB agent perform and document a complete static pressure and temperature profile of the unit prior to any filter upgrades. This should be done [per ASHRAE Standard 111-2008 \(RA 2017\) - Measurement, Testing, Adjusting and Balancing of Building Heating, Ventilation and Air-Conditioning Systems guidance](#). If the existing filters are dirty, have the TAB agent develop the profile with dirty filters installed, then change to clean filters of the same type as existing and develop a second profile. The profile should also document fan and motor RPM and power supply voltage and amp draw at each condition (old dirty filters, old filter type clean and new filter upgrade).



# Epidemic Conditions in Place



## Practical Approach to Increase MERV in an AHU Continued:

6. Obtain the airflow pressure drop of the proposed increased filter efficiency (MERV 13 or higher) and determine the appropriate “dirty filter” setpoint for the new filters. Have the TAB firm insert materials, such as cardboard pieces, to block the existing filters to achieve the upgraded filter dirty setpoint.
7. Have the TAB company develop the unit profile. The profile should also document fan and motor RPM and power supply voltage and amp draw.
8. The team should determine if this is an acceptable temporary operating point for the AHU.
  - a. The TAB agent should be able to calculate the changes in airflow caused by the change in filters and determine the percentage reduction in airflow. If the unit’s airflow does not drop by more than 5% from the original TAB report airflow, unit discharge temperatures do not drop too low, or the airflow is less than the recommended CFM per ton to potentially cause coil freezing or suction pressure issues in DX equipment, then the filter upgrade may not require any further adjustments to the unit.
  - b. If airflow drops to low and causes problems, then have the TAB agent evaluate the fan drive to determine if the fan motor speed may be increased for direct drive fans using variable speed drives or that a sheave change can be made to belt driven fans to get the fan back to its pre-filter change airflow without overloading motor and drive maximum amp ratings.
  - c. If the new filter MERV rated filter pressure drop is too great to allow the unit to operate within 95% of the pre-filter change airflow, consider dropping to a lower MERV filter and repeat the process.
9. Once the appropriate new filter MERV level is determined, obtain a set of filters that can be inserted into this unit's filter frame. Change out the existing filters to the new filters and have the TAB agent develop unit profiles with the new filters installed. The TAB agent should be able to calculate the changes in airflow caused by the change in filters and determine the percentage reduction in airflow. If the unit’s airflow does not drop by more than 5% from the original TAB report airflow, unit discharge temperatures do not drop too low, or the airflow is less than the recommended CFM per ton to potentially cause coil freezing or suction pressure issues in DX equipment then the filter upgrade may not require any further adjustments to the unit.
10. If it is still desired to upgrade the system to a higher efficiency MERV filtration rate, consider retaining a licensed design professional to size and select new fans and motors and/or new air handler to perform to pre-filter change performance criteria with the new filter upgrade pressure drop increase. Have the engineer consider increased static pressure loads on the unit with both clean and dirty filters.
11. If an increase in filter MERV level cannot be accommodated using the existing air handling equipment fans and motors, consider using portable HEPA filter units in high occupancy or high bioburden (such as the building entry) spaces.

# Epidemic Conditions in Place



## Calculation Approach to Increase MERV in an AHU:

The following provides a simple example of how this process might work in the field [2] using the fan laws:

- AHU is equipped with MERV 8 filters.
- Following ASHRAE recommendations, the filter system will be upgraded to MERV 14.
- Commercially available filter data, yields the following information:
  - MERV 8 clean at 0.25 in w.g. and considered dirty at 0.5 in w.g.
  - MERV 14 clean at 0.3 in wg and considered dirty at 1.0 in. w.g.
- The proposed AHU is 23,000 cfm with a supply fan array using variable frequency drives (VFD) controlled to duct static setpoint.
- The analysis will be on a per fan basis.

# Epidemic Conditions in Place



## Calculation Approach to Increase MERV in an AHU Continued:

Filter Level	Supply Airflow CFM	Fan RPM	Static Pressure Fan (in. w.g.)	Fan Brake Horsepower	Fan Motor NamePlate Horsepower
MERV 8	23,000	2,216	5.3 Dirty	5.36	7.5
MERV 14	23,000	2,395	5.8 Dirty	6.7	7.5

### Discussion on the findings of the Calculated Approach:

1. Assuming the unit is under a constant discharge duct pressure control, a static pressure profile of the unit should show a nearly constant pressure in the supply plenum and a gradually increasing negative pressure in the mixing box, filter array and coils on the inlet side of the fan.
2. Energy saving strategies such as reducing the discharge pressure of the unit to serve the VAV box with the greatest air demand should and could still be employed and continued.
3. There is commercially available software that evaluates the costs of material and labor for filter change out intervals. Good testing instrumentation should be available to trend and chart (and if desired record) filter pressure drops.
4. This is only an example. There are potential issues in maintaining airflow at design by increasing fan speeds.
  - a. Fan speed cannot be upgraded because of the limits of that fan construction class is an example. In this case, manufacturers data indicate that the fan maximum rpm is 3125. Check with the fan manufacturer.
  - b. If changing the motor would necessitate an electrical system upgrade, this solution may be cost prohibitive. In this case the owner may choose to operate the system at a reduced air flow. Reduced airflow in this example would be approximately 22,200 cfm.
  - c. Filter bypass is a potential problem. If possible, conduct a light test to determine if there are any major cracks needing closure.
  - d. Cabinet negative pressure leakage is also a potential problem. Check with the manufacturer as they will be following AHRI standards.

# Epidemic Conditions in Place



## Energy Savings Considerations:

The health, safety and welfare of building occupants and maintenance personnel should always come first. This means that facility operators and maintenance personnel should focus on verifying that systems are functioning properly, and maintenance routines are kept as scheduled where possible during the event or crisis. However, for buildings that are experiencing temporary reduced occupancies and closures, the HVAC systems should be operated in their unoccupied modes using relaxed temperature and humidity set points to help reduce energy consumption and cost.

You might want to also consider checking your systems control strategies optimization. The typical building strategies are outlined in [ASHRAE Guideline 36-2018 - High-Performance Sequences of Operation for HVAC Systems](#). While this document does not cover all of the systems, it does give some general guidance to recommended control strategies.

When buildings are scheduled for re-occupancy, guidance for re-starting systems is included in this document and on the [ASHRAE Covid-19 Website](#).



# Epidemic Conditions in Place



## Exhaust Air Re-entrainment

Re-entrainment of contaminants from exhaust air can occur in all buildings. Re-entrainment can occur at any receptor (outside air intake, operable window, doors, etc.). It is important to note that this is not a major concern for buildings that are not intentionally having COVID-19 positive people in the building or spaces. For re-entrainment of the virus to be an issue, there must be someone present in the building shedding, have it captured by the HVAC system, and be exhausted and then re-entrained through the outside air and re-introduced elsewhere. There is a very low percentage of being the transmission route for a building, but warrants being checked.

Please refer to the [Exhaust Re-entrainment Guide](#) for information on the different field investigations:

Level 0 - Observation for Re-entrainment Risk Assessment

Level 1 - Semi-Qualitative Re-entrainment Risk Assessment

Level 2 - Experimental Re-entrainment Risk Assessment

Level 3 - Qualitative based on known emissions Re-entrainment Risk Assessment

Level 4 - Expert Re-entrainment Risk Assessment





# Epidemic Conditions in Place



## Energy Recovery Ventilation (ERV) Systems Operation Considerations

The Building Readiness Team worked with Technical Committee (TC) 5.5 Air-to-Air Energy Recovery to create guidance on how to evaluate if the ERV is well-designed and well-maintained systems that are currently installed in the buildings. Those recommendations are covered in depth in [The Practical Guidance for Epidemic Operation of Energy Recovery Ventilation Systems](#).

The following are critical excerpts of that document that can be applied to ERV systems.

# Epidemic Conditions in Place



## Energy Recovery Ventilation (ERV) Systems Operation Considerations

Many building HVAC systems include Energy Recovery Ventilation (ERV) systems, either stand-alone or integrated with Air-Handling Units (AHUs) or Dedicated Outdoor Air Systems (DOAS). Their purpose is to (1) facilitate or provide outside air ventilation and (2) to reduce the energy use and system capacity required to condition that outside air to comfort conditions.

HVAC Systems and Equipment [ASHRAE Handbook](#) Chapter 26 “Air-to-Air Energy Recovery Equipment” describe the various types of ERVs. It is important to note that this document is focused on ERV units with exhaust and supply ducts co-located in the same cabinet. These are typically rotary wheel and fixed-plate heat or energy exchangers, but occasionally heat pipes and thermosiphon heat exchangers are used in co-located ducts in the same cabinet. Any ERV within co-located ducts and equipment casings has potential for some leakage between airstreams. The coil energy recovery (runaround) loops, heat pipes and thermosiphon heat exchangers when built to provide distance, or a physical separation (an air gap) between the two airstreams, are not.



# Epidemic Conditions in Place



## Energy Recovery Ventilation (ERV) Systems Operation Considerations Continued

Leakage from the exhaust airstream to the supply airstream, if it occurs within the energy exchanger portion of the ventilation system, is referred to as Exhaust Air Transfer (EAT) (T-6). The rate of EAT being passed into the Supply Airflow is called the Exhaust Air Transfer Rate (EATR) (T-5).

In many HVAC systems air from the space also is deliberately Recirculated (T-10) into the supply airstream to the space so that the required heating and cooling can be provided.

Finally, air exhausted from the building can be pulled back into the outside air intakes through Re-entrainment (T-11).

Re-entrainment in an ERV is a specific case of a much larger issue affecting all HVAC systems.

Re-entrainment is discussed in the previous section above in this document.

# Epidemic Conditions in Place



## Energy Recovery Ventilation (ERV) Systems Operation Considerations Continued

When HVAC systems include recirculation, the recirculated portion of the systems entire airflow is typically responsible for the reintroduction of more contaminated air from the space than is EAT in the ERV or from re-entrainment.

Some ERV units or sections are designed to allow for as much as 5% or 10% EATR. This is within ventilation standard allowances and is the most energy-efficient for some spaces and building types.

ERV systems for other spaces and building types such as healthcare facilities are designed to minimize EATR to negligible levels. When well-maintained and properly operated, the EAT may be similar to or an order of magnitude less than the re-entrainment amount.

# Epidemic Conditions in Place



## Energy Recovery Ventilation (ERV) Systems Operation Considerations Continued

Well-designed and well-maintained air-to-air energy recovery systems should remain operating in residences, commercial buildings and medical facilities during the COVID-19 pandemic.

This is because maintaining at least normal outside air ventilation rates, with proper temperature and humidity conditioning of the inside space, is important for maintaining health and combatting infectious aerosols.

Dilution of contaminants, including infectious aerosols, by outdoor air ventilation is an integral IAQ strategy in [ASHRAE Standard 62.1](#). A properly designed system also includes filtration in many forms, along with proper building pressurization controls.

When it is known or expected that an infectious outbreak has or will occur in a building, the ERV systems should be inspected for proper operation and condition and be evaluated for possible contribution of bioburden to the building's supply air.

# Epidemic Conditions in Place



## Energy Recovery Ventilation (ERV) Systems Operation Considerations Continued

The term “well-designed” in the context of this document means:

- The supply and exhaust fan(s) are located correctly for pressure control at the exchanger,
- the ERV is sized for an appropriate velocity and pressure drop, and
- that appropriate seals or purges have been specified (or exist) for the application.

The term “well-maintained” assumes that the well-designed ERV device was:

- installed and set-up,
- tested and balanced correctly during the construction phase, and
- has received manufacturer’s maintenance requirements.

There is much more guidance in Chapter 26 Air-to-Air Energy Recovery Equipment of the [ASHRAE Handbook](#).

In addition, [TC-5.5](#) has produced [practical advice for inspection here](#).



# Epidemic Conditions in Place



## Energy Recovery Ventilation (ERV) Systems Operation Considerations Continued

In a pandemic environment, it must be recognized that even if the units and systems are designed properly, they must have been constructed and maintained properly to ensure they are not allowing excess transfer of exhaust air to supply air.

It is also possible that the facility was not designed with pandemic conditions in mind.

The facility maintenance team should do a check of their systems, in accordance to the manufacturer's guidance. That should include consulting the original engineer of record, a Commissioning Provider and a Test and Balance (TAB) agent, if needed, to determine the ERV device is functioning properly based on the current situation and needs.



# Epidemic Conditions in Place



## Energy Recovery Ventilation (ERV) Systems Operation Considerations Continued

Changing system settings and sequences of operation without a good understanding of the effects on system operation could result in unintended consequences. These could include reduced outdoor ventilation rates or the loss of control of indoor humidity conditions, both which could increase the potential, may themselves favor the spread of viruses.

When competent system operators are available, and the ERV has been deemed to be well-maintained, the most appropriate adjustment generally would be to continue operation of the ERV component appropriate to climate conditions and to potentially increase outside air ventilation rates.

Increasing ventilation rates is consistent with the [ASHRAE Position Document – Infectious Aerosols](#) and recommendations from REHVA.



# Epidemic Conditions in Place



## Energy Recovery Ventilation (ERV) Systems Operation Considerations Continued

### Systems using Heat Pipes, Run-around loops and Thermosiphon exchangers with air gaps

When these systems are built with the supply and exhaust sides separated by a physical distance/air gap between the two airstreams, systems using coil energy recovery (runaround) loops, heat pipes, and thermosiphon heat exchangers will not have Exhaust Air Transfer into the supply airflow. They should be inspected to ensure that:

1. airflows are being maintained at design levels
2. filters are in good condition
3. fluid flow rates are per design
4. refrigerant charges are correct

# Epidemic Conditions in Place



## Energy Recovery Ventilation (ERV) Systems Operation Considerations Continued

### Remediation of Systems with ERV Exchangers

If further inspection, than what is detailed herein, of the ventilation system is necessary, additional considerations should be added to the assessment.

# Epidemic Conditions in Place



## ERV Systems Design Considerations

The energy-recovery wheel or plate exchanger is a sub-component of the overall system and any analysis should be made based upon the total system configuration.

The following types will be discussed:

- Systems with Intentional Recirculation
- Systems with 100% Outside Air (No Recirculation)

# Epidemic Conditions in Place



## ERV Systems with Intentional Recirculation

If the ERV exchanger is installed in a system where the outdoor air portion of the total system airflow is being processed through the ERV, but a portion of the return air is being recirculated back to the space as shown in Figure 1 (as are most conventional packaged systems) then turning off the wheel would do little to improve the supply air quality since the EATR associated with the wheel could be small compared to the recirculation rate.

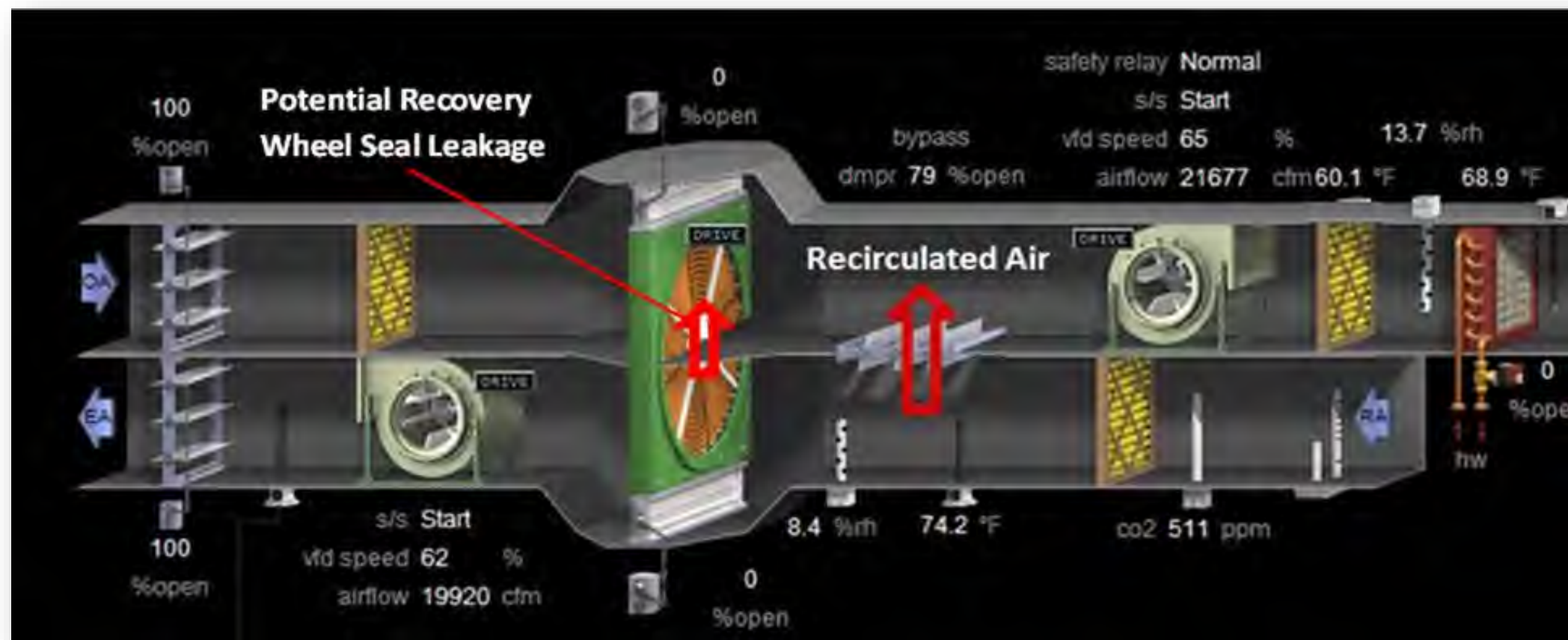

Figure 1 AHU Configuration with Recirculated Air and Energy Recovery Wheel Heat Exchanger

# Epidemic Conditions in Place



## ERV Systems with Intentional Recirculation Continued

However, if the unit has the capacity and capability such that the return air dampers can be closed and the system can be operated as a 100% outdoor air unit, this mode of operation might be preferred when pandemic concerns exist.

To accomplish this, the supply and return outside air ventilation rates should be increased, the recirculation damper closed, and the system balanced so that static pressures are correct for the exchanger type.

**See the following section for a discussion of static pressures.**



# Epidemic Conditions in Place



## ERV Systems with 100% Outside Air (No Recirculation)

If the recovery wheel is installed in a system that is processing 100% outdoor air (no intentional recirculation of return air) then the system re-entrainment and the exchanger EAT following system operational parameters should be considered to establish and assess any relative source of cross-contamination associated with the energy recovery wheel in the system.

Whether there is EAT at an ERV is strongly determined by the fan positioning in the energy recovery unit or HVAC system.

If the static pressure in the supply side of an exchanger is at least 0.5 inches water column (often abbreviated 0.5" or 0.5 in. H<sub>2</sub>O) greater than the static pressure in the return side air entering the energy recovery wheel, then any seal leakage will move from the clean to the dirty airstream and any carry-over will be insignificant.

Under these pressures, energy wheels equipped with a properly installed purge section have an EATR less than 1% and in some cases approaching zero. This can be substantially less than the re-entrainment previously discussed.





# Epidemic Conditions in Place



## ERV Systems with 100% Outside Air (No Recirculation) Continued

Exhaust Air Transfer can occur in ERV units or HVAC systems using plate exchangers as well. In most cases the Exhaust Air Transfer rates are lower, and the driving forces are confined to the static pressure differentials between the compartments adjacent to the exchanger.

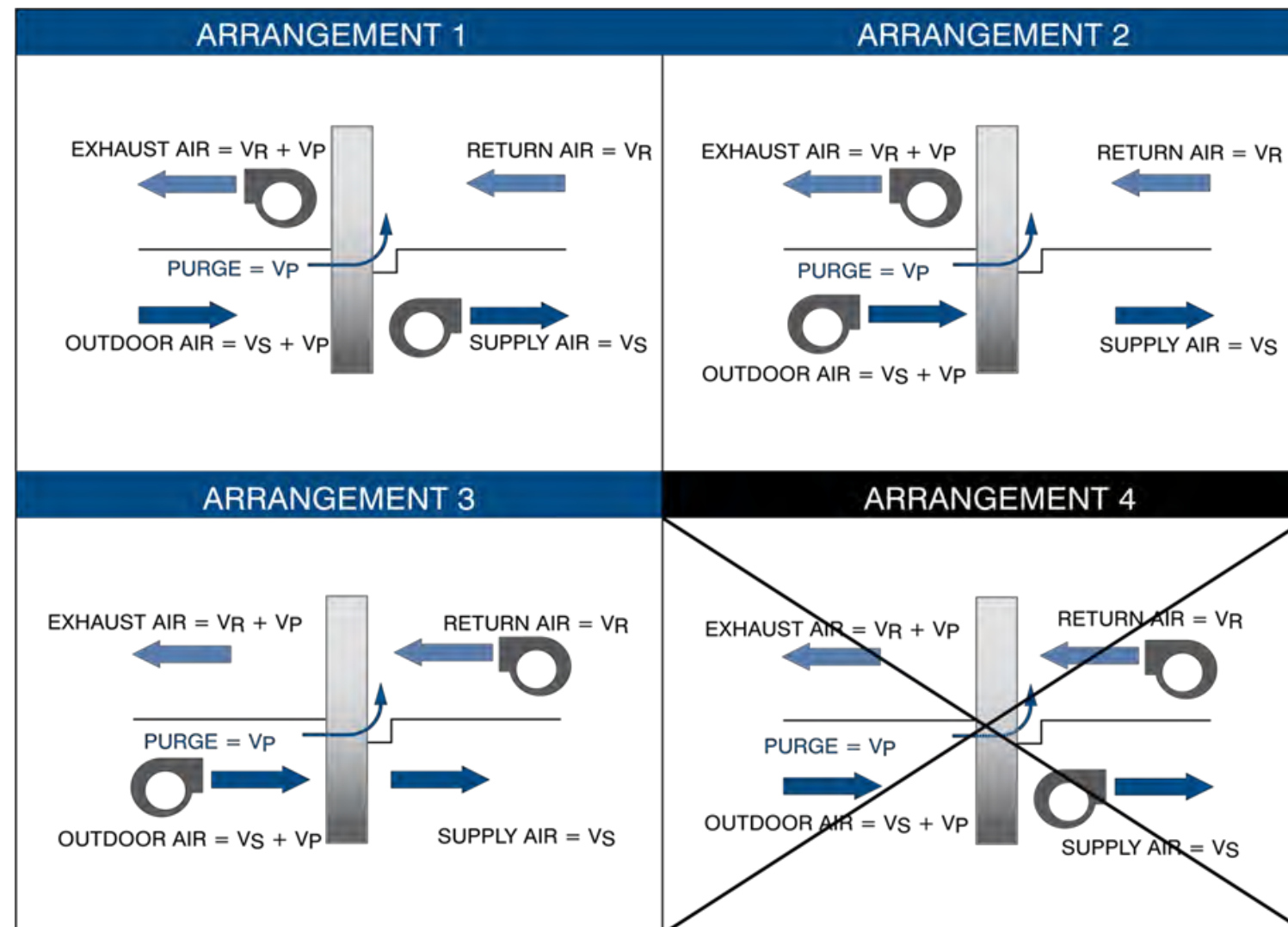

Figure 2 Fan arrangements for energy recovery exchangers

# Epidemic Conditions in Place



## ERV Systems with 100% Outside Air (No Recirculation) Continued

[Figure 2](#) shows the potential fan configurations used for energy recovery or DOAS systems.

Fan positioning: **Arrangement 4 should not be used** since the seal leakage will always go from the dirty to the clean airstream and the purge section will not function in this manner. Exhaust Air Transfer ratio in excess of 10% will be typical.

Almost all energy recovery systems installed will employ either Arrangement 1 or Arrangement 2, and both can be effective in limiting Exhaust Air Transfer provided that a proper minimum pressure differential exists between the return and supply airstreams.

If a system uses Arrangement 2, and if, for wheels, a purge section is in place and the wheel is rotating in the proper direction (discussed later) then it is almost certain that leakage will move from clean to dirty and the purge section will function well with air carry-over being generally less than 1%, and therefore there is no need to measure to confirm system pressures except in the most critical applications. Arrangement 2 works well for plate exchangers as well.

# Epidemic Conditions in Place



## ERV Systems with 100% Outside Air (No Recirculation) Continued

If a system uses arrangement 1 or 3 shown in [Figure 2](#), the static pressures at the inlets and outlets of the exchanger can be significantly impacted by the location of the supply fan being either before (blow through) or after (draw through) filters, coils and other components.

The pressure drops or rises caused by other components in the system including filters, ducts and coils can affect the pressure differential between the supply and exhaust sides of an energy wheel significantly.

# Epidemic Conditions in Place



## ERV Systems with 100% Outside Air (No Recirculation) Continued

The direction of leakage at the exchanger cannot be predicted without an understanding of the static pressures at the exchanger, but general trends, particularly with stand-alone ERV units, are as follows:

**Rooftop units:** these are typically ducted only at the exhaust air inlet and supply air outlet of the unit, so static pressure at the exchanger entering exhaust airflow is usually lower than at the entering supply airflow, therefore leakage is from outside air to exhaust air;

**Indoor units:** these are typically ducted at both inlet and outlet:

- When pressure drop between the unit and the building's inlet and outlet grilles are low compared to those on the other side of the unit, leakage at the exchanger again tends to be from supply to exhaust, resulting in no or low EATR.
- When pressure drop between the unit and the building's inlet and outlet grilles are high compared to those on the other side of the unit, leakage at the exchanger tends to be from exhaust to supply, and Exhaust Air Transfer occurs.

# Epidemic Conditions in Place



## ERV Systems with 100% Outside Air (No Recirculation) Continued

The above discussion is not intended as a substitute for inspection and validation that the ERV exchanger or unit is operating effectively, but as a guide to understanding the behavior of these systems and the mechanisms by which air from the building return and exhaust systems can be reintroduced to its supply air, intentionally or unintentionally.



# Epidemic Conditions in Place



## ERV Systems: On-Site Inspection of All Types and Systems

This section provides the first steps in field inspection of ALL units or systems with ERV exchangers. It is assumed that the maintenance personnel is wearing the appropriate PPE for this process.

With system documentation in-hand, if possible:

1. Clean the unit with a vacuum to facilitate inspection. It may be helpful to remove filters in order to inspect the exchanger(s).
2. Clean the exchanger surface as recommended by the manufacturer, or simply clean the exchanger with a vacuum and soft brush (use a HEPA vac if possible, and always if the unit is inside a building).
  - NOTE: Some exchangers can be washed, others cannot. Confirm with the heat exchanger manufacturer that the cleaning and disinfection solutions proposed to be used are compatible with the heat exchanger's frame and heat exchange media.
3. Check for gross leak paths between compartments that might result from age or deterioration. Check inside the cabinet to see if light is coming in thru fastener holes or seams.



# Epidemic Conditions in Place



## ERV Systems: On-Site Inspection of All Types and Systems Continued

This section provides the first steps in field inspection of ALL units or systems with ERV exchangers. It is assumed that the maintenance personnel is wearing the appropriate PPE for this process.

With system documentation in-hand, if possible:

4. Verify that seals exist on cabinet/casing access doors and that they are in good condition to prevent air from bypassing the exchanger between the access door and the wheel's structural frame.
5. Check that the bypass and other damper are operating properly, not jammed, and that the damper seals are in good condition.
6. Determine the general layout of the system and identify the four compartments adjacent to the energy recovery exchanger, referring to Figure 6 for the standard designations. Also identify any bypasses between compartments.
7. Check filters: dirty filters affect airflow and pressure differentials.
8. Verify the outdoor air path is not obstructed (e.g. by clogged intake screen or louvers).

# Epidemic Conditions in Place



## ERV Systems: On-Site Inspection of Energy Wheels

For a person not very familiar with the energy recovery wheel device here are the very first steps to take when inspecting for proper operation.

Armed with the building systems documentation perform the following:

- Inspection with System Turned Off
- Inspection with System Operating
- Evaluation for Leakage

# Epidemic Conditions in Place



## ERV Systems: On-Site Inspection of Energy Wheels Continued

### Inspection with System Turned Off

1. **Is the wheel clean?** This can affect both flow and leakage. A dirty wheel will change the operating characteristics of the fan system.
2. **Is there visible damage or areas of wear such as loose media, damaged media or degraded structural integrity?** These will affect the operation of the wheel and system.
3. **Are the seals set properly?** The two most common types of seals are contact/non-contact seals and you would have to refer to the original manufacturer to determine the proper setting. Seals should be inspected for wear. Older wheels that rely on seals that are in contact with the wheel surface may have seals that are worn or damaged.
4. **Is the wheel equipped with a purge?**

# Epidemic Conditions in Place



## ERV Systems: On-Site Inspection of Energy Wheels Continued

### Inspection with System Turned Off

Purge sections a difficult item to provide guidance for as 90% of the purges are fixed. End users should be able to contact the wheel manufacturer using a fixed purge, and with the measured purge pressure, be given an estimate on the EATR.

Coupled with operating flows/pressures that aren't equivalent to the scheduled values, little can be done aside to changing system operational characteristics to match the scheduled values or providing a new purge to match the buildings operational characteristics.

Static pressure is the value that is most often inconsistent with the scheduled values.

# Epidemic Conditions in Place



## ERV Systems: On-Site Inspection of Energy Wheels Continued

### Inspection with System Operating

With the system running and any wheel bypasses closed, confirm and record the following information:

- 1. Is the wheel turning?** Many projects rely on the building management system or some other indicator, but the only sure way is to visually inspect. This should also include a determination that the wheel rotation direction is correct. To confirm proper rotation, a spot on the wheel should rotate from the return/exhaust airstream into the supply/outdoor airstream.
- 2. Is the wheel rotating at the correct speed (RPM)?** An incorrect factory speed can be attributed to a replacement motor/pulley combination being used or an improperly programmed VFD. (Note: since Exhaust Air Transfer is lower at reduced wheel rotation speeds, it is most important that actual wheel rotation speed not be higher than the designed speed).



# Epidemic Conditions in Place



## ERV Systems: On-Site Inspection of Energy Wheels Continued

### Inspection with System Operating

With the system running and any wheel bypasses closed, confirm and record the following information:

3. **Is the wheel turning in the correct direction?** When the wheel is equipped with a purge section, the wheel must rotate in a specific direction, see Figure 3.

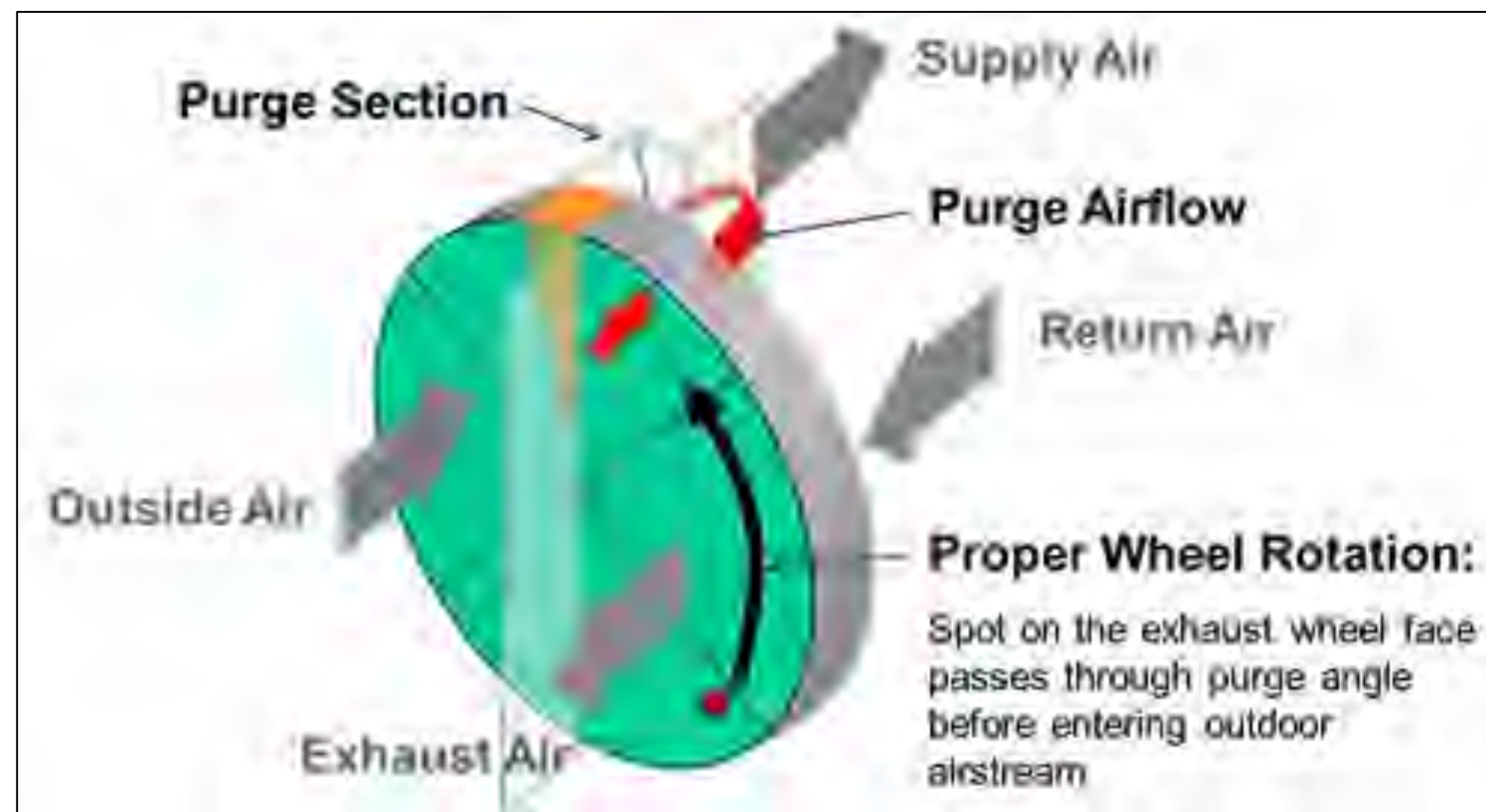

Figure 3 Illustration of the purge section and correct rotation direction for purge operation



# Epidemic Conditions in Place



## ERV Systems: On-Site Inspection of Energy Wheels Continued

### Inspection with System Operating

With the system running and any wheel bypasses closed, confirm and record the following information:

4. With the ERV system operating normally with all bypass(es) closed, measure and record the static pressures in each of the four compartments around the exchanger. If the ERV has more than one operating mode, repeat this process. [Figure 4](#) shows the items necessary to determine this information.

# Epidemic Conditions in Place



## ERV Systems: On-Site Inspection of Energy Wheels Continued

### Inspection with System Operating

### ERV Wheel Exchanger Measurements

Draw in Blowers Locations and Airflow Directions

Date:					
Jobsite:					
Location:					
Unit #:					
Record at a minimum: SP2 SP3 Leaving Supply Airflow Rotation Speed Purge Angle					
Rotation Speed:					
Purge Angle:					

Airstream:	
Static Pressure: (in.w.g.) (Pa)	
Airflow Rate: (CFM) (l/s)	

Airstream:	
Static Pressure: (in.w.g.) (Pa)	
Airflow Rate: (CFM) (l/s)	

Airstream:	
Static Pressure: (in.w.g.) (Pa)	
Airflow Rate: (CFM) (l/s)	

Airstream:	
Static Pressure: (in.w.g.) (Pa)	
Airflow Rate: (CFM) (l/s)	

SP1	static pressure measured at Entering Supply Airflow Compartment 1
SP2	static pressure measured at Leaving Supply Airflow Compartment 2
SP3	static pressure measured at Entering Exhaust Airflow Compartment 3
SP4	static pressure measured at Leaving Exhaust Air Airflow Compartment 4

Supply-side Pressure Drop	(in. w.g.) (Pa)
Exhaust-side Pressure Drop	(in. w.g.) (Pa)

Figure 4 Field Recording Sheet for ERV Exchanger Operating Parameters

# Epidemic Conditions in Place



## ERV Systems: On-Site Inspection of Energy Wheels Continued

### Inspection with System Operating:

Record the following items:

SP1	Record static pressure measured at Entering Supply Airflow Compartment 1
SP2	Record static pressure measured at Leaving Supply Airflow Compartment 2
SP3	Record static pressure measured at Entering Exhaust Airflow Compartment 3
SP4	Record static pressure measured at Exhaust Air Outlet Compartment 4

Table 1 Static Pressure Designations at Compartments adjacent to Exchanger

# Epidemic Conditions in Place



## ERV Systems: On-Site Inspection of Energy Wheels Continued

### Evaluation for Leakage

1. Leaving Supply static pressure (P2) should be at least 0.5 in. w.g. greater than the entering return airstream static pressure (P3) measured near the wheel surfaces. This means there is a positive static pressure differential.
2. Positive pressure differential means the pressure at the supply outlet (P1) of the wheel is higher than the exhaust inlet of the wheel.

As shown in [Figure 5](#), this causes seal leakage in the desired direction: from supply air to return to be exhausted.

3. Pressure differential as-installed is frequently different from the original pressure differential calculated during design, refer to the original commissioning report, if available, that identified the as-installed initial pressure differential.



# Epidemic Conditions in Place



## ERV Systems: On-Site Inspection of Energy Wheels Continued

### Evaluation for Leakage

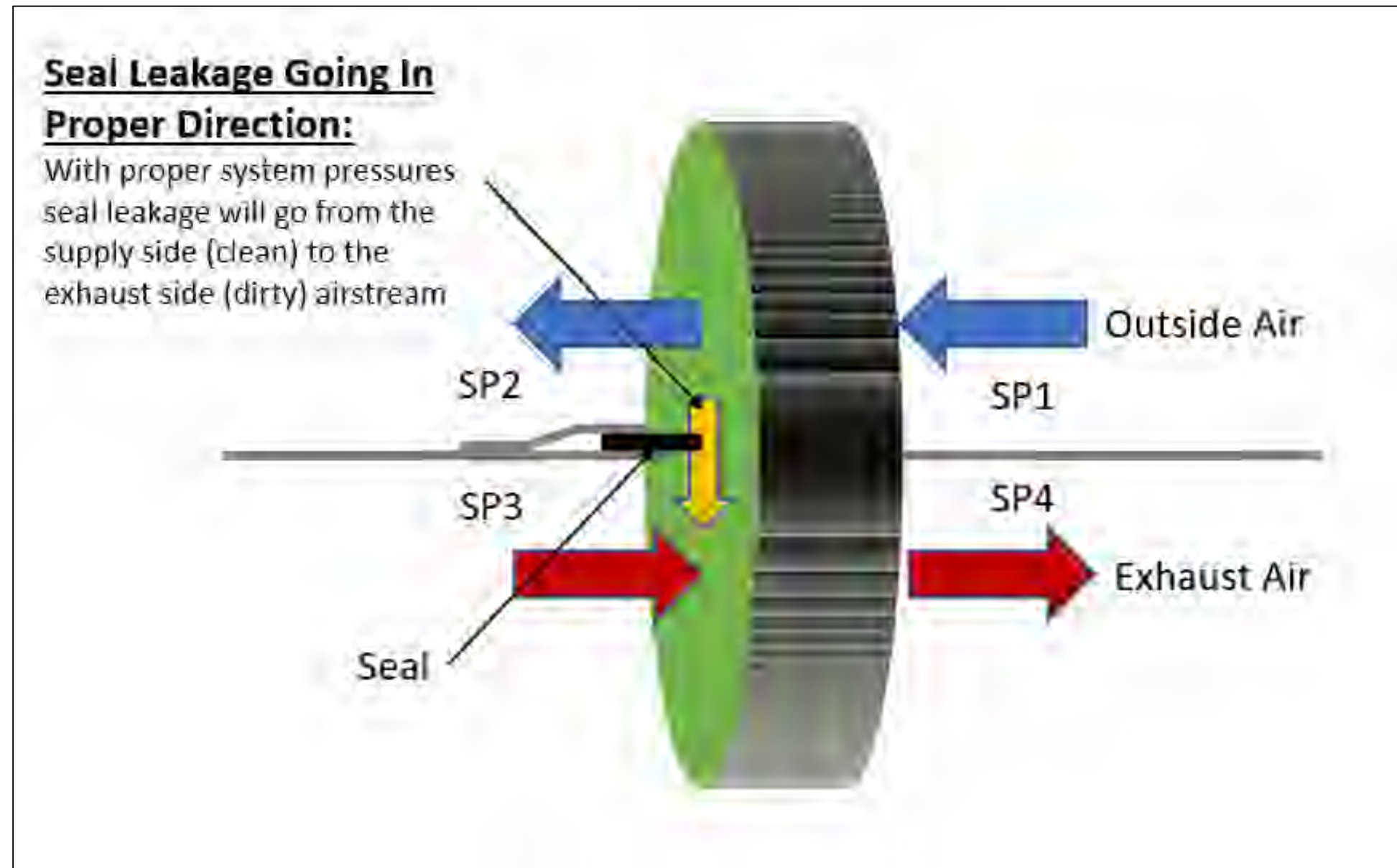

Figure 5 Supply static pressure should be higher than exhaust static pressure

# Epidemic Conditions in Place



## ERV Systems: On-Site Inspection of Energy Wheels Continued

### Evaluation for Leakage

4. If there is a driving force for exhaust air transfer to the supply ( $P_2$  greater than  $P_1$ ), ask the ERV manufacturer for an EATR prediction. Provide the manufacturer the following information, at minimum: SP1, SP2, SP3, Rotation Speed, Purge Angle (if one is used) and Leaving Supply Airflow Volume.
5. Request the estimated exhaust air transfer as a volume rate (e.g. in CFM) at the specific operating condition.
6. To determine the Leaving Supply Airflow Volume, measure it directly if possible.



# Epidemic Conditions in Place



## ERV Systems: On-Site Inspection of Plates (or Heat Pipes with co-located ducts)

For a person not very familiar with the heat plate device here are the very first steps to take when inspecting for proper operation.

Armed with the building systems documentation perform the following:

- Inspection with System Turned Off
- Inspection with System Operating
- Evaluation for Leakage

# Epidemic Conditions in Place



## ERV Systems: On-Site Inspection of Plates Continued (or Heat Pipes with co-located ducts)

### Inspection with System Turned Off

1. Clean the exchanger surface as recommended by the manufacturer, or simply clean the exchanger with a vacuum and soft brush (use a HEPA vac if possible, and always if the unit is inside a building). Some exchangers can be washed, others cannot.
2. Check the exchanger for any splits that connect adjacent compartments, shrinkage or broken seals around the framing.
3. Determine the general layout of the system and identify the four compartments adjacent to the energy recovery exchanger. Also identify any bypasses between compartments.

# Epidemic Conditions in Place



## ERV Systems: On-Site Inspection of Plates Continued (or Heat Pipes with co-located ducts)

### Inspection with System Operating

1. With the ERV system operating normally with all bypass(es) closed, measure and record the static pressures in each of the four compartments around the exchanger. If the ERV has more than one operating mode, repeat this process.

Refer to [Table 1](#) Static Pressure Designations at Compartments adjacent to Exchanger for a key to the static pressure designations. See also [Figure 4](#) Field Recording Sheet for ERV Exchanger Operating Parameters.

**Note:** The original wheel design may have required bypass dampers to be partially open to allow for a certain amount of air to bypass the wheel all the time. If that is the case, the bypass dampers should be set to the position established by the original TAB agent when the unit was originally TAB'd.

2. For each operating mode, measure or estimate the airflow rate in at least the ERV Exhaust inlet and the ERV Supply outlet.

# Epidemic Conditions in Place



## ERV Systems: On-Site Inspection of Plates Continued (or Heat Pipes with co-located ducts)

### Evaluation for Leakage

1. SP1 should be higher than SP2. If not, there is no outdoor air flow, compartments are misidentified, or outdoor airflow is backwards.
2. SP3 should be higher than SP4. If not, there is no exhaust air flow, compartments are misidentified, or exhaust airflow is backwards.
3. If SP3 is greater than SP1 or SP2, there is a driving force for exhaust air transfer into the supply.
4. If SP4 is greater than SP1 or SP2, there is a driving force for exhaust air transfer into the supply.
5. If SP1 is a negative pressure, check again that the outside air path is not obstructed. After cleaning or replacing filters measure the pressures again.

# Epidemic Conditions in Place



## ERV Systems: On-Site Inspection of Plates Continued (or Heat Pipes with co-located ducts)

### Evaluation for Leakage

6. If there is a driving force for exhaust air transfer to the supply (condition 3 or 4 above), ask the ERV manufacturer for an EATR prediction. Provide at minimum: SP1, SP2, SP3, Rotation Speed, Purge Angle (if one is used) and Leaving Supply Airflow Volume.
7. Request the estimated exhaust air transfer as a volume rate (e.g. in CFM) at the specific operating condition.
8. To determine the Leaving Supply Airflow Volume, measure it directly if possible.

**NOTE:** Some manufacturers of plate exchanger units provide charts which correlate pressure differences between the inlet and outlet compartments to the flow rate. Describe the condition of the exchanger to the manufacturer and ask whether these charts remain valid.

# Epidemic Conditions in Place



## UVGI SYSTEMS

There is a lot of ASHRAE (and others) guidance on ultraviolet (UV) technology for the built environment.

Please refer to some of the documentation to determine the best application for your building or systems:

- Filtration and Disinfection Guidance on the ASHRAE COVID-19 site
- Chapters in ASHRAE Handbook
  - [2019 Applications - Chapter 62: ULTRAVIOLET AIR AND SURFACE TREATMENT](#)
  - [2016 Systems and Equipment - Chapter 17: ULTRAVIOLET LAMP SYSTEMS](#)
- [ASHRAE Journal article: Ultraviolet Germicidal Irradiation - Current Best Practices \(2008, Martin et al\)](#)
- For upper room systems – [NIOSH guidelines \(2009\)](#)



# Epidemic Conditions in Place



## Bipolar Ionization and other Emerging Technologies

ASHRAE consulted with CDC regarding the use of Bipolar Ionization and other emerging technologies and received the following guidance:

*“CDC does not provide recommendations for, or against, any manufacturer or manufacturer’s product.*

*While bi-polar ionization has been around for decades, the technology has matured and many of the earlier potential safety concerns are reportedly now resolved. If you are considering the acquisition of bi-polar ionization equipment, you will want to be sure that the equipment meets UL 2998 standard certification (Environmental Claim Validation Procedure (ECVP) for Zero Ozone Emissions from Air Cleaners) which is intended to validate that no harmful levels of ozone are produced.*

*Relative to many other air cleaning or disinfection technologies, needlepoint bi-polar ionization has a less-documented track record in regard to cleaning/disinfecting large and fast volumes of moving air within heating, ventilation, and air conditioning (HVAC) systems. This is not to imply that the technology doesn’t work as advertised, only that in the absence of an established body of evidence reflecting proven efficacy under as-used conditions, the technology is still considered by many to be an “emerging technology”.*

*As with all emerging technologies, consumers are encouraged to exercise caution and to do their homework. Consumers should research the technology, attempting to match any specific claims against the consumer’s intended use. Consumers should request efficacy performance data that quantitatively demonstrates a clear protective benefit under conditions consistent with those for which the consumer is intending to apply the technology. Preferably, the documented performance data under as-used conditions should be available from multiple sources, some of which should be independent, third party sources.”*



# Epidemic Conditions in Place



## Domestic Water & Plumbing Systems

Building owners and operators should review the following industry guidance related to building shutdowns and re-opening:

- Centers for Disease Control and Prevention (CDC) - [Guidance for Reopening Buildings After Prolonged Shutdown or Reduced Operation](#):
- American Water Works Association (AWWA) - [Shutoffs and Return to Service Guidance](#)
- US Environmental Protection Agency - [Information on Maintaining or Restoring Water Quality in Buildings with Low or No Use](#)
- [ASHRAE Standard 188-2018: Legionellosis: Risk Management for Building Water Systems](#)
- [Guideline 12-2020 - Managing the Risk of Legionellosis Associated with Building Water Systems](#)
- Departments of Health – Building owners and operators should be aware of information provided by their state or local Departments of Health
- Water Utility Providers – Building owners and operators should coordinate with water utility providers.

# Epidemic Conditions in Place



## Domestic Water & Plumbing Systems Continued

Building owners and operators should review existing water management plan or program documents. If this document is not available, develop a water management program for your water system and all devices that use water.

Guidance to help with this process is available from CDC and others.

In general, fresh water should be drawn into building water systems and stagnant water flushed out before they are reopened.

# Epidemic Conditions in Place



## Domestic Water Systems Continued

Keep water above 140°F to avoid microbial incursion. Do not let it drop below 120°F. Refer to Figure 1 from [ASHRAE Guideline 12-2020](#):

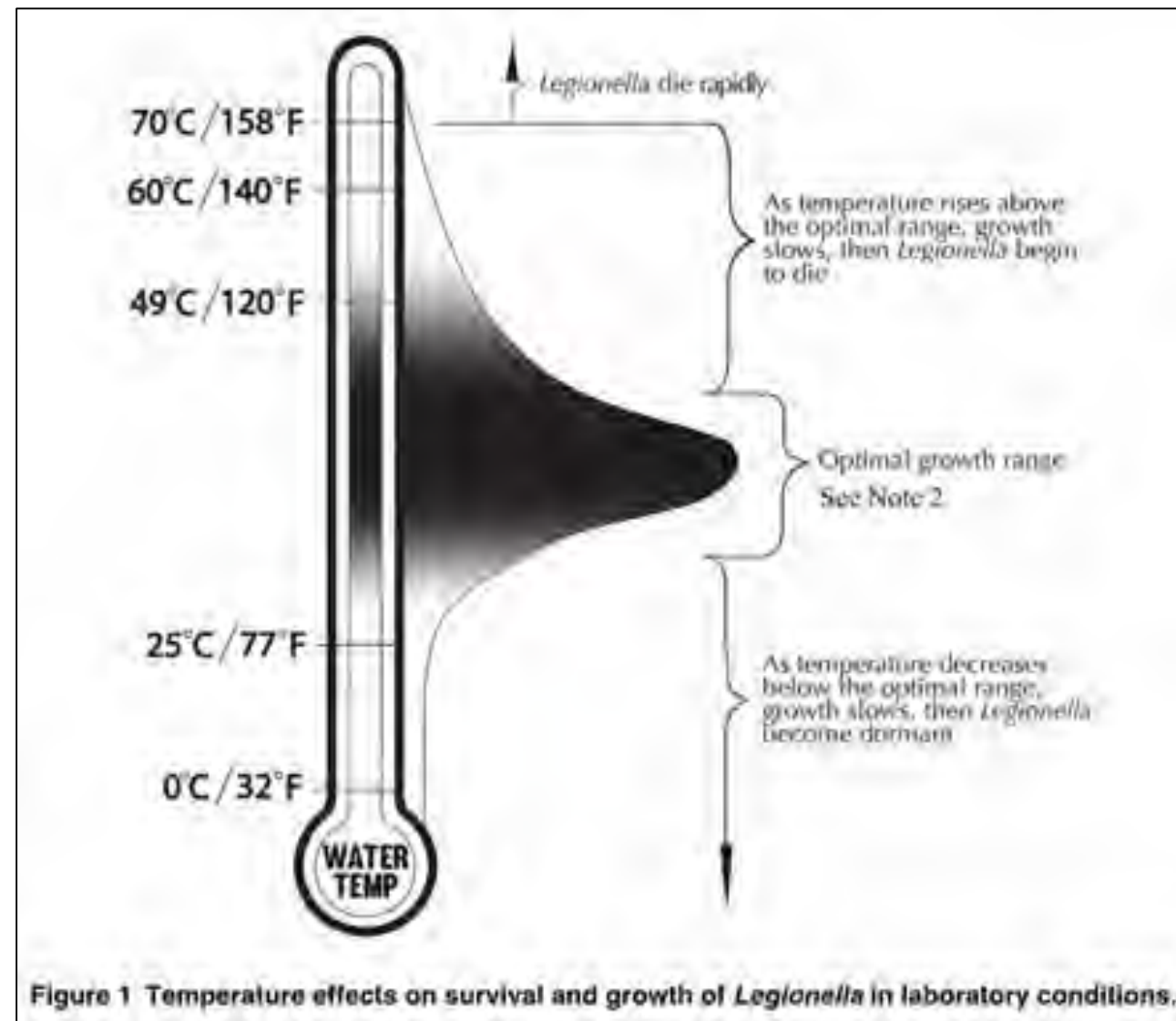

# Epidemic Conditions in Place Maintenance Checks



For equipment within a building that is not identified within this response, we recommend referring to the following documents for additional guidance:

- [ASHRAE Standard 180-2018: Standard Practice for Inspection and Maintenance of Commercial Building HVAC Systems.](#)
- [ASHRAE Standard 188-2018: Legionellosis: Risk Management for Building Water Systems](#)
- [ASHRAE Guideline 12-2020: Managing the Risk of Legionellosis Associated with Building Water Systems](#)

# Epidemic Conditions in Place Maintenance Checks



## General Recommendations:

- Notify Tenants of exact dates and times the building will be setback.
- Check remote or offsite access connections to the Computerized Maintenance Management System (CMMS), Building Management System (BMS), and Building Automation System (BAS) to make sure they are functioning properly and can be logged into, if any.
- Assign personnel rotation for weekly onsite rounds, provide a schedule for the rounds and trades.
- Set up a log for tracking all adjustments and trends to identify deviations from the program.
- Verify all the modes modified are working daily.



# Epidemic Conditions in Place

## Maintenance Checks



### Heating, Ventilating & Air-Conditioning

Where semi-annual / annual scheduled maintenance on the equipment can be performed safely, do not defer this maintenance cycle. Where worker safety could be at risk, consider deferment of semi-annual / annual maintenance on the equipment up to 60 days.

**The following are recommended as minimum verification/checks to be performed:**

#### **Boilers (Monthly):**

- For systems with Steam Boilers, develop a schedule that provides minimum supervision on-site.
- Perform chemical testing of system water. Verify water treatment target levels are being maintained.
- For systems using fuel oil
- Check fuel pump for proper operation.
- Inspect fuel filter; clean and verify proper operation.
- For systems using natural gas
- Check gas pressure, gas valve operation, and combustion fan operation.
- Check for evidence of leakage of fuel supply, heat transfer fluid, and flue gas.
- Verify proper operation of safety devices per manufacturer's recommendations.

#### **Chillers (Monthly):**

- Perform chemical testing of system water. Verify water treatment target levels are being maintained.
- Check control system and devices for evidence of improper operation.
- Check variable-frequency drives for proper operation.

# Epidemic Conditions in Place

## Maintenance Checks

### Heating, Ventilating & Air-Conditioning Continued:



#### **Air Cooled Chillers:**

- Check refrigerant system for evidence of leaks
- Check/clean fan blades and fan housing
- Check/clean for fin damage
- Check for proper fluid flow and for fluid leaks

#### **Water Cooled Chillers:**

- Check refrigerant system for evidence of leaks
- Check for proper fluid flow and for fluid leaks
- Check compressor oil level and/or pressure on refrigerant systems having oil level and/or pressure measurement means

#### **Cooling Towers and Evaporative-Cooled Devices (Monthly):**

- Perform chemical testing of system water. Verify water treatment target levels are being maintained.
- Check chemical injector device for proper operation
- Check conductivity and other sensors for proper readings
- Check water system ultraviolet lamp, replace bulbs as needed (if applicable)
- Check control system and devices for evidence of improper operation
- Check variable-frequency drive for proper operation
- Check for proper fluid flow and for fluid leaks
- Check for proper damper operation
- Inspect pumps and associated electrical components for leaks and normal operation

# Epidemic Conditions in Place

## Maintenance Checks



### Heating, Ventilating & Air-Conditioning Continued:

#### Steam Distribution Systems (Monthly):

- Perform chemical testing of system condensate and feed water
- Check piping for leaks
- Check steam traps and condensate return units for proper operation
- Check safety devices per manufacturer's recommendations

#### HVAC Water Distribution Systems (Monthly):

- Perform chemical testing of system water. Verify water treatment target levels are being maintained.
- Check for proper fluid flow and for fluid leaks. If necessary, vent air from system high points and verify backflow preventers and pressure regulating valves on makeup water lines are functioning properly.
- Check expansion tanks and bladder type compression tanks have not become waterlogged

#### Pumps:

- Inspect pumps and associated electrical components for proper operation
- Check variable-frequency drive for proper operation
- Check control system and devices for evidence of improper operation

#### Air Handling Units (Monthly):

- Check for particulate accumulation on filters, replace filter as needed
- Check ultraviolet lamp, replace bulbs as needed (if applicable)
- Check P-trap
- Check control system and devices for evidence of improper operation
- Check variable-frequency drive for proper operation

# Epidemic Conditions in Place

## Maintenance Checks



### Heating, Ventilating & Air-Conditioning Continued:

#### Roof Top Units (Monthly):

- Check for particulate accumulation on outside air intake screens and filters, replace filter as needed
- Check ultraviolet lamp, replace bulbs as needed (if applicable)
- Check P-trap
- Check control system and devices for evidence of improper operation
- Check variable-frequency drive for proper operation
- Check refrigerant system for leaks
- Check for evidence of leaks on gas heat section heat-exchanger surfaces
- Check variable-frequency drives. For fans with belt drives, inspect belts and adjust, as necessary

#### Water-Source Heat Pumps (Monthly):

- Check for particulate accumulation on filters, replace filter as needed
- Check P-trap
- Check control system and devices for evidence of improper operation

# Epidemic Conditions in Place

## Maintenance Checks



### Plumbing Systems

Follow recommended operations as outlined in the Building's Legionella Management Plan. In absence of this plan, the following are minimum recommendations.

- Water features and fountains - shutdown per manufacturer's instructions and drain.

#### Plumbing Rounds (Weekly):

- Flush piping systems through drinking fountains, lavatories, urinals, water closets and sinks to prevent stagnation
- Verify wet floor sinks and drains remain wet
- Check for proper fluid flow and for fluid leaks
- Inspect booster pumps system for proper operation
- Inspect Domestic Hot Water heater for production of hot water at 140°F
- Inspect pumps and associated electrical components for proper operation
- Check the recirculation system for proper flow and for fluid leaks
- Inspection of secondary disinfection system for proper operation (if applicable)



# Epidemic Conditions in Place

## Maintenance Checks



### Electrical Systems:

- Disconnect all non-essential appliances wherever possible from power outlets.  
Coordinate with building tenants or departments.
- Turn off lights, keep the emergency and egress lighting energized.

### Special Systems:

- Inspect fire alarm master panels and other life safety equipment with battery backup power supplies are functioning. (Weekly)
- Inspect the battery backup power supplies for IT and IOT devices and mission critical systems. (Weekly by IT personnel)
- Run emergency or backup generators, test transfer of power, per manufacturer's recommendations. (Monthly)



# Shut Down a Building Temporarily



## General Recommendations:

1. Notify relevant people of the need to shut down or partially occupy the building. Include exact dates and times the building will be shut down.
2. Backups and Data Protection—Backup all necessary computer data, e.g. building control systems and servers to local and/or cloud-based backup services and media.
  - a. If there are tenants that need to use the building during lockdown, they should refer to the Commercial Building Guide on [ashrae.org/COVID19](https://www.ashrae.org/COVID19) site under the “**Buildings**” section, as the building may not be able to be shut down.
3. Check important remote or offsite access connections to the Building Management System and Building Automation System (BMS includes more than the HVAC controls in the BAS) to make sure they are functioning properly and can be logged into, if any. For example, remote observation via the security and access platforms, such as security cameras, locks, alarms and more can help monitor the building for emergencies remotely.
4. Operators should ensure that they have electronic copies of their building plans, past test and balance reports, operation and maintenance (O&M) manuals, systems manual and other pertinent information to operate the building.
5. If someone does visit the building to check, they could also be tasked with watering any of the plants.

# Shut Down a Building Temporarily



## Heating, Ventilating & Air-Conditioning

### 1. In buildings equipped with a Building Automation Systems (BAS):

- a. It is not recommended to completely shut off HVAC systems in a building that is being temporarily shut down or unoccupied for an undetermined amount of time during an emergency.
- b. Operate or place the HVAC systems in the Unoccupied Mode using the BAS. For example, if the system is normally controlled to a 70°F heating with 40% RH and 75°F cooling setpoint at about 55% RH when the building is occupied, then having the limits in heating at set back to 65°F, 40% RH and cooling limits up to (80°F, 60% RH) is reasonable. If the limits are exceeded while in the Unoccupied Mode, the systems should be enabled and allowed to operate, with the OA dampers at minimum and exhaust fans off, until the space returns the Unoccupied Setpoint conditions. The intent is to maintain the building within a reasonable range of temperature and humidity conditions to help avoid developing poor indoor conditions while reducing energy consumption during the shutdown.
- c. If occupants are going to be allowed to use the building on a partial or limited basis during a shutdown, it may be desirable to program an override into the BAS to allow the systems to be returned to normal Occupied modes of operations for temporary length of time, such as for two hours. After the override period expires, the system should automatically return to the Unoccupied setpoints.
- d. Check if all the setbacks and setup modes are working.

### 2. A building without a BAS may require more set-up time to have the building be shuttered and may require more direct monitoring on site during the shutdown.

- a. Recommend that the HVAC systems should not be completely shut down in any building where the building is being unoccupied for any length of time if the intent is to re-occupy the building in the future.
- b. In addition, we do not recommend extreme setbacks for heating thermostat setpoints or extreme setup for cooling thermostat setpoints. The intent is to set the individual controls on the equipment to do the following—maintain a cooling space setpoint of 80°F and less than 60% RH in cooling and 65°F and minimum 40% RH in heating.
- c. Any outside air dampers should be set to their minimum position for building pressure. The exhaust fans other than those in restrooms and critical applications should be turned off.
  - i. If the OA dampers are closed, all exhaust fans shall be turned off.
- d. Monitoring the building regularly to ensure that no unexpected consequences are occurring such as condensation, moisture or fungal growth on HVAC system components or building surfaces and finishes.

# Shut Down a Building Temporarily



## Heating, Ventilating & Air-Conditioning Continued:

### 3. Boilers and distributed hot water:

- a. If the building has more than one boiler, reduce the number of operating boilers to bare minimum needed. If the building is going to be offline for more than 60 days, dry storage is recommended via desiccants or inert gas blanketing. If using inert gas, follow OSHA safety protocols.
- b. For boilers less than 300 hp, a heat source (light bulb) with a fan may be enough. Warm wet storage is acceptable; oxygen scavenger residuals in the boiler should be 500% of normal (i.e. if you normally run 20 to 40 ppm of sodium sulfite, maintain 100-200 ppm during mothball period).
- c. Maintain 400-600 ppm P-alkalinity during wet storage.
- d. Boilers should fire and circulate once per week for a minimum of 1 hour.
- e. **Cold wet storage is discouraged!** Equipment could suffer significant corrosion damage.
- f. If the boilers are offline, drain all deaerators, feed water tanks, surge/condensate receivers, superheaters and economizers. If you cannot drain them, make sure they are fully flooded, and oxygen scavenger levels are at 500% of normal.
- g. If steam lines are idle, make sure all steam traps and condensate receivers are empty. Be prepared to dump condensate for several days upon restart due to flash rusting developing on the interior surfaces of the lines.

### 4. Cooling towers, chillers and chilled water distribution piping:

- a. Many facilities have a water risk management plan such as an [ANSI/ASHRAE Standard 188-2018, Legionellosis: Risk Management for Building Water Systems](#), to provide guidance and protocols to minimize the risk of water borne pathogens, such as *legionella pneumophila* in their utility water systems. If you have a plan and it addresses shut down and restarts of this magnitude, follow it. If you do not have a plan:
  - i. Keeping systems running keeps the equipment in the best shape. Set the BAS to unoccupied temperature and humidity setbacks and monitor and adjust to preserve IAQ and building elements.
  - ii. With all mechanical systems, if you do not use it, nature takes it back. If you are taking chilled water systems down for an extended period, completely drain the cooling towers, chillers, heat exchangers and associated piping. Leaving the system with stagnant water can result in severe corrosion, biofouling and contribute to transmission of Legionnaires' disease. Be prepared for rust and biological incursions when bringing branch lines back into service. Do a complete system flush to restore design water parameters and clean strainers throughout. Consider adding side stream filtration.
  - iii. Try to maintain circulation in main chilled water loops, the larger the loop the greater the importance.
  - iv. If operating at reduced capacities for extended duration, for HVAC hydronic loops, increase the frequency of testing and adjusting of biological control regimen by your water treatment provider.

# Shut Down a Building Temporarily



## Domestic Water & Plumbing Systems:

1. Building owners and operators should coordinate with local authorities having jurisdiction, state or local Departments of Health and water utility providers for policies adopted and recommended best practices for low or no occupancy situations.
2. Review existing water management plan or program documents and execute steps for system shutdown. If this document is not available, develop a water management program for your water system and all devices that use water. Guidance to help with this process is available from CDC and others.
3. Many water risk management plans provide guidance and protocols to minimize the risk of waterborne pathogens such as legionella pneumophila in their utility water systems.
4. Regularly turn on the water and run the drinking fountains, lavatories, urinals, water closets and sinks. Do this once a week or as needed to maintain a minimum disinfectant residual and avoid issues with stagnant water.
5. Make sure all plumbing P and U-traps are wet (filled with water) and check them routinely during the unoccupied times.



# Shut Down a Building Temporarily



## Domestic Water & Plumbing Systems Continued:

6. Water features should be shut down and properly drained , including ice machines, coffee makers or other devices with water reservoirs. This should be part of the water risk management plan.
7. Consider shutting down and draining water heaters.
8. If water heaters continue to operate, ensure water heaters are properly maintained, the temperature is correctly set, and water is circulating.

Keep water above 140°F to avoid microbial incursion. Do not let it drop below 120°F. Refer to Figure 1 from [ASHRAE Guideline 12-2020](#).

# Shut Down a Building Temporarily



## Domestic Water & Plumbing Systems Continued:

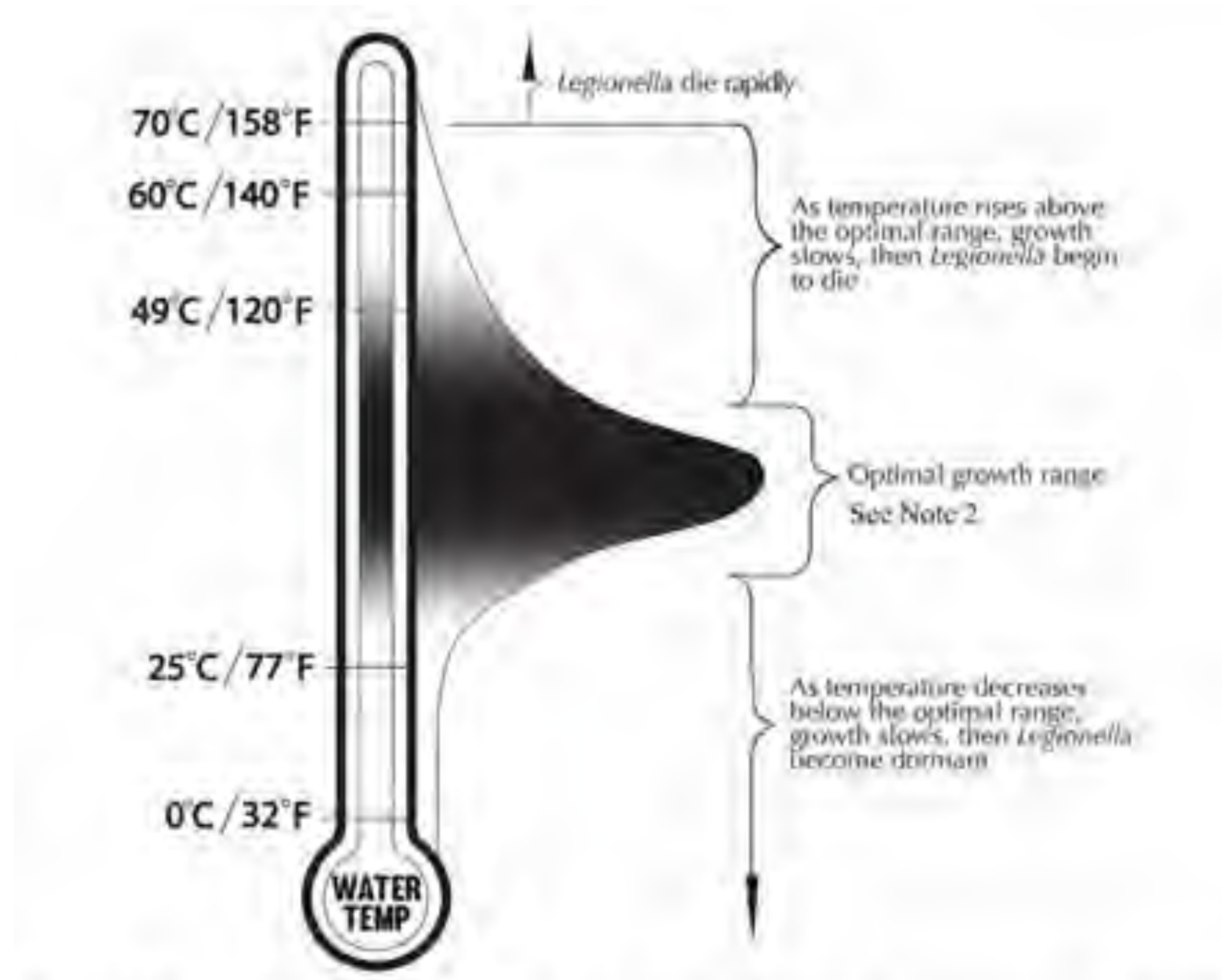

Figure 1 Temperature effects on survival and growth of *Legionella* in laboratory conditions.



# Shut Down a Building Temporarily



## Electrical Systems:

1. Unplug or disconnect non-essential appliances wherever possible— unplug any and all appliances that don't need to stay powered on to avoid "[Vampire or Phantom Appliances](#)".

### These including but are not limited to:

- Computers
- Routers
- Modems
- Televisions
- Printers
- Chargers
- Microwaves
- Vending machines (remove food that may spoil before disconnecting vending machines that store food and perishables)
- Things that turn on with a remote control

2. It is important to work with your IT department because some computers and monitors will need to remain powered on to facilitate remote desktop functions for remote working employees.

# Shut Down a Building Temporarily



## Special Systems:

1. Check on fire alarms and other equipment with battery backup power supplies. Consider having an electrical technician come and check that everything is working properly.
2. Check on the battery backup power supplies for IT and IOT devices, especially the ones that are mission critical. These items include but are not limited to servers, BAS, communication systems, lighting control systems and security systems.
3. If the building is equipped with an emergency or backup generator, arrange to have it tested regularly as required by codes, local jurisdictions and the manufacturer's recommendations.

# ECiP - Systems Manual



A Systems Manual should already be in place for normal operations which is a system-focused composite document that includes the design and construction documentation, facility guide and operation manual, maintenance information, training information, commissioning process records and additional information of use to the Owner during occupancy and operations. If there is not an existing Systems Manual, refer to [ASHRAE Guideline 1.4-2019: Preparing Systems Manuals for Facilities](#) for guidance to build that document.

While the Systems Manual should include all modes of operation, it is unlikely that it would include a mode for Epidemic Conditions in Place. During an Epidemic, the Systems Manual should be updated to include special operations and considerations such as:

1. Indicate which systems will remain online without alterations.
2. Indicate which systems will remain online with alterations.
  - a. Detail special provisions
  - b. Detail revised sequences of operations
  - c. Include any BAS checks to make sure the proper mode is engaged
3. Indicate which systems will be de-energized
  - a. If these include water systems, indicate how those will get water flow occasionally to avoid growth issues
4. Outline daily activities and documentation that might be different than the normal facilities checks. Include updated data logs and forms as needed.

Just as a normal Systems Manual might be used in the training of the operations and facility staff and occupants before and during normal operations, the updated Systems Manual that includes the Epidemic Conditions in Place Mode should also be used to train operations and facility staff and occupants. This training should be done prior to switching to Epidemic Conditions in Place Mode for the facility and during the event.

# Re-opening During Epidemic Conditions in Place



1. There are many buildings that are re-occupying prior to the Epidemic or Pandemic being fully over for your locale.
2. Please refer to the ["P-EciP: Prior to Occupancy"](#) section of this document.

# Post-Epidemic Conditions in Place (P-ECiP)



There are actions that should be done prior to occupying a building that has been unoccupied or shut down during the epidemic versus the continued operation after it has been made ready for occupancy. This document splits those into:

## **Prior to Occupying**

## **Operational Considerations once Occupied**

The following items should be done based on a Safety Benefit analysis for your system, building, occupancy and climate. These are general suggested actions that need to be applied to your specific systems in your specific building.

# P-ECiP: Prior to Occupying



## Re-starting a Building

The intent of re-starting a building is for when the work-remote orders are retracted, and the threat of exposure is greatly reduced. Those are listed below for many systems in the building. If you are restarting a building still at a high-level threat of exposure, please review following information in the “**Buildings**” section on the [ashrae.org/COVID19](https://www.ashrae.org/COVID19) site.

- [Commercial Building Guide](#)
- [Schools](#)
- [Healthcare](#)
- [Transportation](#)



# P-ECiP: Prior to Occupying

## General recommendations

1. Prior to starting the building, operators may want to create a strategic plan that includes the following:
  - a. Create measures to make occupants feel safer
  - b. Ensure supply chain for critical items, such as filters, as confirmed for delivery
  - c. Review contractual agreements with tenants with regards to building support
  - d. Establish a communication protocol with tenants and include key contacts
  - e. Prepare and provide training for tenants on safety measures

**It is important to note, that if you are opening when PPE requirements are still in place, the Occupancy Guides should be referenced as they deal with functioning buildings during the epidemic.**

2. Notify relevant people - include exact dates and times that the building will be reopened.
3. Follow all local, state and federal executive orders, statutes, regulations, guidelines, restrictions and limitations on use, occupancy and separation until they have been officially relaxed or lifted.
4. Follow CDC advice regarding PPE
5. Follow OSHA Guidelines



# P-ECiP: Prior to Occupying



## General recommendations continued:

6. Ensure that custodial scope includes proper cleaning procedures built from EPA, OSHA and CDC guidance on approved products and methods:
  - a. Disinfect high-touch areas of HVAC and other building service systems e.g. on/off switches, thermostats
7. Review the BAS programming to adjust the systems to align with the accepted requirements in the Operational Considerations once Occupied Section.
8. Install signage to encourage tenants to use a revolving door, if any, rather than opening swing doors in the lobby area.
9. Review all procedures to consider the addition of “touchless” interactions where applicable. As an example, auto-flush valves are considered “touchless”.
10. Engage a qualified Commissioning Provider (CxP), TAB firm, and/or BAS contractor to verify sensor calibration for demand-based ventilation instrumentation, airflow measurement instrumentation and temperature control instrumentation.
11. Engage a mechanical service company, if not already under contract, to inspect and assess the operational capabilities of all mechanical refrigeration equipment (i.e. chillers and DX cooling equipment), water heaters, steam boilers, pumps and associated specialties (i.e. expansion tanks, deaerators, traps, PRVs, mixing stations, etc.).
12. Consider future renovations, to be included in the capital budget, to incorporate some of the strategies to mitigate transmission of viruses as indicated in the [ASHRAE Position Document “Infectious Aerosols”](#) as well as the Occupancy Guides at [ashrae.org/covid19](https://www.ashrae.org/covid19).

# P-ECiP: Prior to Occupying



## Heating Ventilating & Air Conditioning:

1. ASHRAE recommends that all building owners and service professionals follow the requirements of [ASHRAE Standard 180-2018 “Standard Practice for the Inspection and Maintenance of Commercial HVAC Systems”](#) which has tables to show the typical maintenance on equipment that has been in operation
2. Consider PPE when maintaining ventilation materials, including filters and condensate. Consult additional guidance before duct cleaning.
3. Confirm occupancy schedule with building tenants and review programmed operation schedule in BAS and/or HVAC components (i.e. unitary controls). Modify as needed to fit the current occupancy schedules and ventilation requirements.
4. Open outside air intake dampers to their maximum, 100% preferred, four hours minimum, before the reoccupation. The maximum position the outside air dampers may be opened will depend on the time of year, local climate, the temperature and humidity of the outside air and the capability of the HVAC equipment to condition the outside air so that the system is able to maintain acceptable indoor temperature and humidity. When operating in this “flush out” mode, monitor the system continuously to make sure that unexpected or unacceptable conditions inside do not develop.
5. In buildings with operable windows, if the outside air temperature and humidity are moderate, consider opening all windows for two hours minimum before the reoccupation.
6. Operate the HVAC systems in Occupied mode for at least 24 hours after completing the previous steps. Trend temperature control and ventilation parameters through the BAS. If this capability is not available, request a qualified Commissioning Provider or TAB firm install monitoring equipment or measure systems to verify proper temperature and ventilation control. Be advised that equipment may be operating below design capacity, but sequencing and temperature control should function correctly.
  - Check to see that space temperature and relative humidity levels are being controlled to the acceptable setpoints.
7. Verify Occupied / Unoccupied sequencing after measurement and verification of Occupied parameters is complete.
8. Check the status of any heat recovery wheels in the systems for leakage and cross-contamination. Consider deactivating these wheels until a service technician checks the operation and condition.
9. Consult with the CxP, BAS contractor, TAB firm or Design firm to identify any areas of concern or anomalies in the monitored or measured data and compile a list of issues to be addressed to meet minimum occupancy ventilation requirements and occupant comfort / operational temperature setpoints.

# P-ECiP: Prior to Occupying



## Airside Systems:

1. Check to see that the fans have turned on, and that air is moving in and out of the building.
2. Check to make sure the dampers (outside and return) are working properly as this helps control the fresh air to the building. If the building increased its outside air (OA) during the epidemic, rebalancing the dampers may be required to achieve design air flows.
3. Check overall building pressure to make sure it is positive. Do the same for any critical interior spaces.
4. Check that the filters are still in acceptable condition. Facility staff should wear PPE, assuming the system may have been contaminated prior to shut down or upon restarting.
5. Operators should consider increasing the level of filtration in the Air Handling Units (AHUs) for one or two replacement cycles upon opening the building. Make sure the air handling systems and fans can overcome the additional pressure drop of the new filters and still maintain air flow at acceptable levels. Refer to the [Filtration Guidance](#).

If higher efficiency filtration is not available, portable units in the high-traffic areas may be used for a few months.



# P-ECiP: Prior to Occupying



## Cooling systems:

1. Check the refrigerant pressures to make sure the system is adequately charged.
2. Check the water quality in the systems and add chemicals as needed.
3. Check coil leaving air temperatures to make sure the systems are providing dehumidification.
4. Check the water levels and make-up water source for cooling towers to ensure they are available.
5. Check pump operation and that water is flowing.

## Heating System:

1. Check the fuel source to make sure it is on and available. Old fuel oil may need to be replaced.
2. Confirm that the flues and make-up air paths are open prior to engaging boilers.
3. Check that the coil actuators are controlling to temperature, or that heating elements are turned on at the disconnect.
4. If the boiler system(s) were shut down, follow state boiler codes and the manufacturer's written instructions for starting up, and bring hot water and steam heating systems and plants back online.

# P-ECiP: Prior to Occupying



## Building Automation System:

1. Check that the devices and sensors are within an acceptable calibration for controlling space comfort and ventilation. Use the guidance in [ASHRAE Guideline 11-2018 -Field Testing of HVAC Control Components](#).
2. Check that the alarms are set up and their communication path is correct (it is notifying the right person).
3. Consider an update to the programming that would incorporate HVAC strategies to reduce virus transmission prior to future events. Automate the control sequences applied as “Epidemic Mode” operations that can be manually selected by the operator with one stroke.
  - Refer to Occupancy Guides for suggested HVAC strategies to employ when operating the building in an epidemic.



# P-ECiP: Prior to Occupying



## Building Automation System:

4. Reset and ventilation control strategies to increase outside air back to normal. This means to re-engage demand-controlled ventilation and potentially eliminate the pre- and post- occupancy flushing.
5. Filters should be replaced, at the normal interval, back to the previous MERV level. It makes financial sense to wait until the currently installed filter pressure drop indicates it needs to be changed. Refer to filter modification notes to determine required adjustments to the system to achieve initial operating conditions.
6. Make sure your toilet exhaust fans are now set to turn off in unoccupied mode if that is how it was previously operated.

# P-ECiP: Prior to Occupying



## Domestic Water & Plumbing Systems:

Building owners and operators should coordinate with local authorities having jurisdiction, state or local Departments of Health and water utility providers for policies adopted and recommended best practices prior to building occupancy.

Review existing water management plan or program documents and execute steps for system start-up. If this document is not available, develop a water management program for your water system and all devices that use water. Guidance to help with this process is available from CDC and others.

Utilize the following steps:

# P-ECiP: Prior to Occupying



## Domestic Water & Plumbing Systems Continued:

1. In general, fresh water should be drawn into building water systems and stagnant water flushed out before they are reopened.
2. Maintenance staff should wear epidemic-level PPE when maintaining any sewage ejectors and lift stations until those systems are sterilized.
3. Ensure your water heater is properly maintained and the temperature is correctly set.

Keep water above 140°F to avoid microbial incursion. Do not let it drop below 120°F. Refer to Figure 1 from [ASHRAE Guideline 12-2020](#):

# P-ECiP: Prior to Occupying

## Domestic Water & Plumbing Systems Continued:

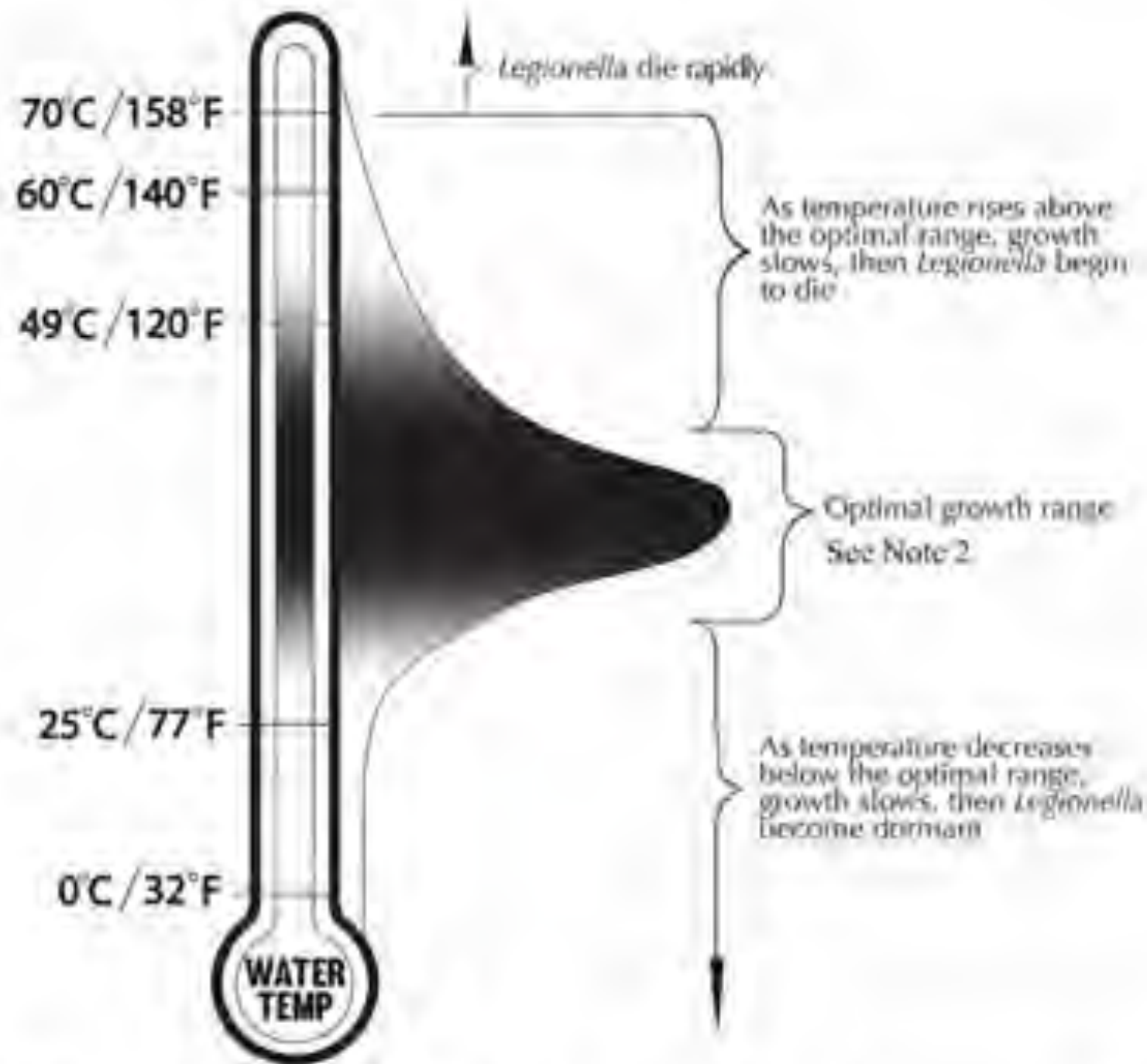

Figure 1 Temperature effects on survival and growth of *Legionella* in laboratory conditions.

# P-ECiP: Prior to Occupying

## Domestic Water & Plumbing Systems Continued:

### 4. Flush your water system:

If applicable, flush water distribution system mains to maintain water quality delivered to buildings. Coordinate with local water utility provider as needed to confirm water residual disinfectant levels are maintained. Coordinate with local water utility provider and authorities having jurisdiction to complete other testing in water mains such as free chlorine, lead, Heterotrophic Plate Count (HPC) or Legionella Pneumophila.

Flush building cold water loops through all points of use, including all water-using appliances like ice machines, humidifiers and dishwashers. Flushing may occur in segments or by zone. Ensure a minimum disinfectant residual is achieved before usage. Coordinate with local water utility provider and authorities having jurisdiction to complete other testing in building water systems such as free chlorine, lead, Heterotrophic Plate Count (HPC) or Legionella Pneumophila. Discolored water can be a sign of more complex issues and should be investigated.



# P-ECiP: Prior to Occupying



## Domestic Water & Plumbing Systems Continued:

5. Evaluate water filtration for systems and individual devices to determine if replacement is needed.
6. Make sure all P and U-traps on plumbing drains are wet.
7. Clean all decorative water features, such as fountains.
8. Ensure hot tubs/spas are safe for use.
9. Ensure cooling towers are clean and well-maintained.
10. Ensure safety equipment including fire sprinkler systems, eye wash stations, and safety showers are clean and well-maintained.



# P-ECiP: Prior to Occupying



## Electrical Systems:

Plug in all appliances that were unplugged to avoid phantom electrical loads, including but not limited to:

- a. Computers
- b. Routers
- c. Modems
- d. Televisions
- e. Printers
- f. Chargers
- g. Microwaves
- h. Things that turn on with a remote control

# P-ECiP: Prior to Occupying



## Special Systems:

1. Check on fire alarms and other equipment with battery backup power supplies. Consider having an electrical technician come and check that everything is working properly.
2. Have fire protection sprinkler systems, fire alarm systems, emergency lighting systems and other life-safety systems inspected by local authorities having jurisdiction (AHJs), if required by state and local statutes and ordinances, and by contract service professionals who routinely maintain these systems.
3. Check on the battery backup power supplies for Information Technology (IT) and Internet of Things (IOT) devices, especially the ones that are mission critical. That would include servers, building automation systems (BAS), communication systems, lighting control systems and security systems.
4. If the building is equipped with an emergency or backup generator, arrange to have it tested as required by codes, local jurisdictions and the manufacturer's recommendations.

# P-ECiP: Operational Considerations once Occupied



The intent is to return your building to the new normal mode of operation for your facility, but what is the new normal? There are questions the facility needs to address as it modifies its systems.

In general, use the Building Readiness Plan to re-open your building. In addition, continue to follow the [CDC advice regarding PPE](#) and [OSHA Guidelines for workspaces](#).

Next, let's capitalize on some of the lessons learned, which may adjust your new normal, that the facility has experienced with the recent COVID Pandemic by exploring the following questions:

# P-ECiP: Operational Considerations once Occupied



**Did your maintenance program have any scheduled preventive maintenance periods missed because the building was unoccupied?**

- This would include any monthly, quarterly, semi-annual or annual inspections and service.

If the answer is yes, then get these back on schedule without putting the current and upcoming maintenance at risk.

- Current and upcoming maintenance should continue as scheduled.
- Prioritize the missed maintenance items, starting with any annual maintenance missed, for the longest period since the last annual inspection and maintenance.
- Move to the semi-annual then the quarterly.
- Start scheduling these missed service intervals on equipment over the next month to catch up.
- With the quarterly inspections, if you are a month or less to the next quarterly inspection it might make sense to just skip the missed inspection cycle.

If the answer is no, continue with the current maintenance cycle as scheduled.

# P-ECiP: Operational Considerations once Occupied



**Did you have issues acquiring parts or consumable maintenance materials during the pandemic period?**

If the answer is yes, consider generating a stock backlog of commonly used parts or consumables. Of course, one needs to always pay attention to this by using the stock and restoring the backlog as items are used to keep items with shorter shelf life current. This can be a challenge at some locations, as space is a true premium.

If the answer is no, continue with the current program, but think forward. Is there anything in your stock that would be a problem if you could not acquire it in another event?

# P-ECiP: Operational Considerations once Occupied



**Were you able to continue daily or weekly rounds at the building during the shut down?**

If the answer is yes, review the notes from the rounds. If issues were identified start scheduling maintenance repairs to address any issues such as filters, leaking flanges, loose belts or sticking flush valves.

If the answer is no, consider going through your facility with diligence to ensure that all systems have returned to normal operations. Here is a list of easy low hanging fruit to look for, but certainly not all encompassing:

- Look closely at consumables, have any dried out and require replacement or refilling?
- Are all the filters still in the filter rack and not sucked in?
- Any visible leaks on the piping or plumbing fixtures?
- Do the batteries need to be changed in any paper towel dispensers?
- Are the sensors in the systems reading and reporting correctly?



# P-ECiP: Operational Considerations once Occupied



**Were there systems that were not able to be put into a setback mode?**

If the answer is yes, look at these systems individually and determine a plan for the next long-term pandemic. Ask these questions:

- What prevented the setback mode from happening?
- Can the system be upgraded to have a setback mode?
- How do we implement the upgrade?

If the building is manual operations and not computerized, consider a control upgrade to the system. This could be a large undertaking so prioritize by system criticality. Remember some systems control setbacks just might not make sense.

If the answer is no, continue with the current program.

# P-ECiP: Operational Considerations once Occupied



**Do the building mechanical systems have reset and ventilation control strategies to increase outside air back to normal?**

If the answer is yes, consider adding a schedule for times where the building can be automatically flushed with fresh air in addition to the demand-controlled ventilation increase.

If the answer is no, consider adding this to the next air handler replacement.

# P-ECiP: Operational Considerations once Occupied



**Are there other lessons learned that need to be addressed within the building from this experience?**

Have a round table with the staff maintaining the facility, pull from their thoughts and experiences. Create a master list of the headaches and the problems that were found. Use these to help develop the new capital plan or program for the facility.

# P-ECiP: Ventilation



Post-Epidemic Conditions in Place, the ventilation should be returned to normal quantity and duration prior to the epidemic.

Refer to ventilation modification notes to determine required adjustments to the system to achieve initial operating conditions.

# P-ECiP: Filtration



Post-Epidemic Conditions in Place, the filtration can be returned to normal quantity and duration prior to the epidemic.

Prior to returning systems to their normal state, final measurements and data should be recorded for future use.

- Total airflow and static pressure should be recorded at a minimum, as well as filter status (clean, dirty, other).
- If temporary brackets or other modifications were made to accommodate larger or different style filters during the epidemic, a determination should be made whether or not to keep the modifications in place for possible future use, or if it needs to be removed or changed back in order to return the system to former operations.
- Any left-over filtration not used during the epidemic should be documented and stored for future use, as well as any removed modifications or materials used for modifications.

If owners/operators find that their facility operations were not reduced or hindered by the modifications or increased filtration (higher MERV rating), some facilities may opt to keep the increased filtration in place or shift to a new filtration efficiency. Whether systems are returned fully to pre-epidemic operations, returned to slightly better MERV rating than pre-epidemic operations, or kept in place, final long-term operation should be documented for record purposes (airflow, static pressures, amperages).

# P-ECiP: Building Maintenance Program



Review your existing maintenance program:

- Are there systems within the program that need to be put at a higher priority than pre-pandemic conditions?
- Are there systems or equipment that have more issues than per-pandemic conditions?
- If you are only doing annual or semi-annual inspections and maintenance, is it worth considering adding a more frequent maintenance interval?

We would suggest that each piece of equipment and each system be evaluated individually taking into account what the system serves within the building. Depending on the building, some systems may take a higher priority because of the area of service.



# P-ECiP: Building Maintenance Program



For those who have determined that a more robust maintenance program is required for the HVAC or Plumbing systems, some good resources include:

- [ASHRAE Standard 180-2018: Standard Practice for Inspection and Maintenance of Commercial Building HVAC Systems](#)
- [ASHRAE Standard 188-2018: Legionellosis: Risk Management for Building Water Systems](#)
- [Guideline 12-2020 -- Managing the Risk of Legionellosis Associated with Building Water Systems](#)

For electrical system programs, refer to the [NFPA 70B Recommended Practice for Electrical Equipment Maintenance](#).

# P-ECiP: Systems Manual



As stated above in the [Epidemic Conditions in Place](#), a Systems Manual should be revised to include this new mode of operation for the facility. During an epidemic, there may be altered sequences of operations, as well as data logging information and operations for record keeping. When the epidemic is over and occupants begin to return to the workplace in a more normal capacity, systems will likely be returned to, or near, previous operations.

When returning systems to normal operations, operations staff should review the Occupied and Unoccupied Modes in normal operation to ensure that the document is current. There should be documentation kept of the change over, any anomalies encountered, as well as operational data recorded moving forward, when switching between modes.

The post-change over review should be performed so that any updates that need to be made can be made and put into action.

# Acknowledgements



## Building Readiness Team Members

Wade Conlan (Chair)

Dennis Knight (Vice Chair)

Nate Boyd

Sarah Maston

Justin Garner

Troy Byers

Kent Walters

Jon Sheppard

Heather Platt

Mike Amstadt

Megan Sterl

John Hamilton

Duncan Phillips

Brad Cochran

Hanson Professional Services

Whole Building Systems

University of Central Florida

Green Footprints Commissioning, Inc.

Engineered Air Balance Co., Inc.

Commissioning Consultants, LLP

Control Management, Inc.

Atlantic Testing

Dewberry

Mead & Hunt

Montana State University – Bozeman

TABB

RWDI

CPP

# Acknowledgements



Thanks to the following people for providing input, information, and review of the materials in the development of documents created by the team.

Ben Cherry  
Tommy Taurasi  
Tom Smith  
David Brande  
Ray Bert  
Tiffany Suite  
Robin Bryant  
Tom Smith  
Jon Cohen  
Jay Enck  
Jason DeGraw  
Bill Bahnfleth  
Rick Hermans  
Mike Craig  
Christoph Lohr  
Matthew Friedlander

Trane Orlando  
Trane Orlando  
3Flow  
Retired  
AABC, ACG  
NEBB  
B&I Contractors  
3Flow  
  
CxGBS  
Oak Ridge National Laboratory  
The Pennsylvania State University  
Retired  
RWDI  
LiquiTech / ASPE  
Renewaire

[TC-5.5 Committee](#)



# References

[1] Cooling coil selections provided by Trane Orlando.

[2] ASHRAE HVAC Systems and Equipment Chapter 21 page 21.6 Fan Laws



# Disclaimer



*Information in this document is provided as a service to the public. While every effort is made to provide accurate and reliable information, this is advisory, is provided for informational purposes only, and may represent only one person's view. They are not intended and should not be relied upon as official statements of ASHRAE.*